

FLOOD DAMAGE MITIGATION MEASURES FOR BARAK VALLEY IN SOUTH ASSAM INCLUDING EFFECTS OF CLIMATE CHANGE

REPORT submitted to Assam State Disaster Management Authority

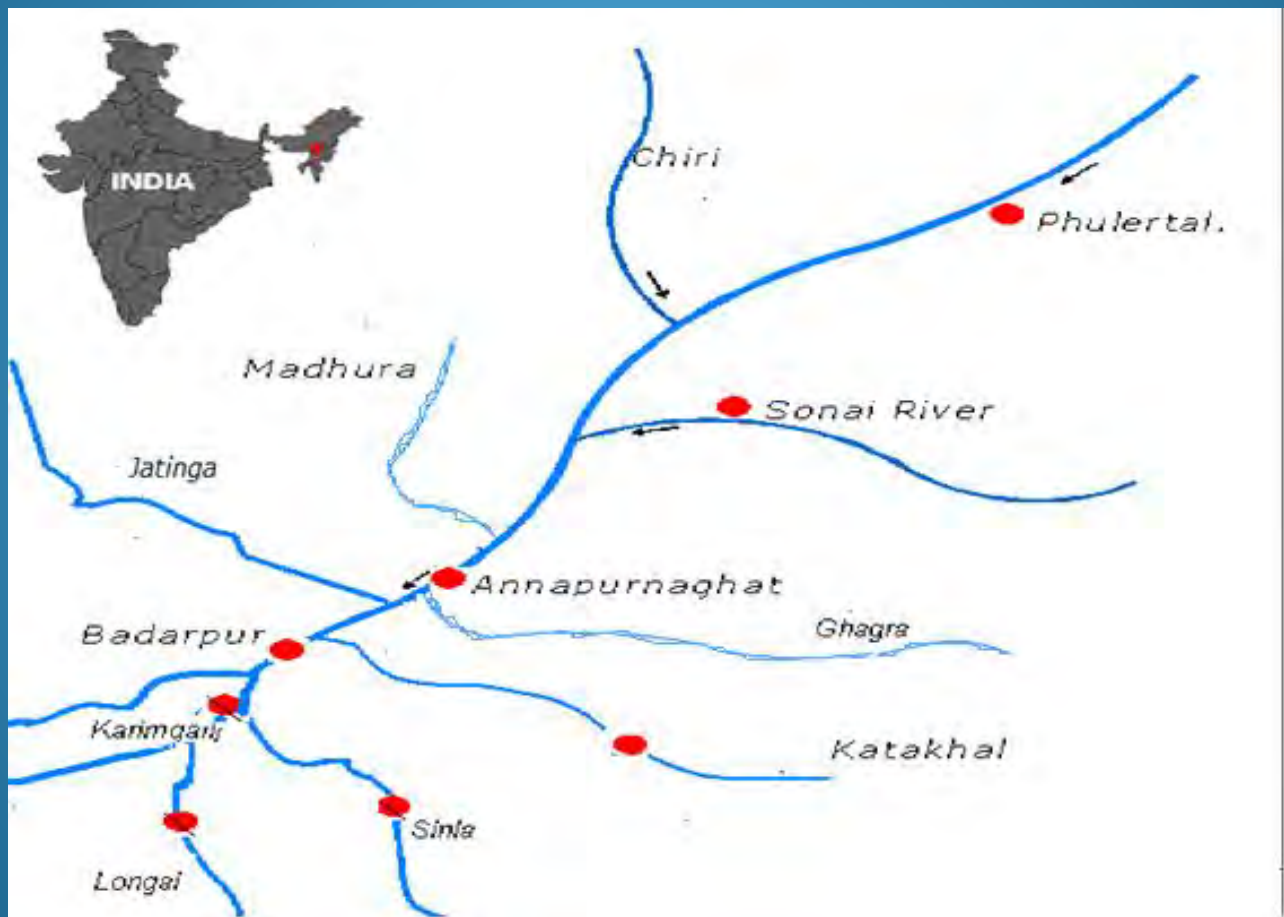

Department of Civil Engineering
NIT Silchar, Assam
July 2014



Working Group

Principal Investigator : Parthasarathi Choudhury
Professor, Department of Civil Engineering
NIT Silchar, Silchar, Assam
Email: ps_chou@yahoo.com

Team members : P.J. Roy, Assistant Professor, Department of
Civil Engineering, NIT Silchar, Assam
: J. Nongthombam, PhD student
: Ms. N.Ullah, PhD student
: Ms. Arti Devi, PhD student
: Ms. S. Debbarman, PhD student

List of Figures:

Figure No	Description	Page no
1.1	Ariel map of the study area	5
2.1	Main River Borak from Lakhipur to Bhanga (upto Bangladesh Border)	11
2.2	Section Details of Barak River upto 500m countryside	15
2.3	Jiri Water shed	21
2.4	Cross sectional details of river Jiri	23
2.5	Ciri Water shed	24
2.6	Cross sectional details of river Ciri	26
2.7	Sonai Water shed	27
2.8	Cross sectional details of river Sonai	31
2.9	Badri Water shed	33
2.10	Cross sectional details of river Badri	35
2.11	Madhura Water shed	36
2.12	Cross sectional details of river Madhura	38
2.13	Jatinga Water shed	39
2.14	Cross sectional details of river Jatinga	41
2.15	Gagra Water shed	42
2.16	Cross sectional details of river Gagra	45
2.17	katakhal Water shed	47
2.18	Cross sectional details of river katakhal	51
2.19	Longai Water shed	52
2.20	Cross sectional details of river Longai	56
3.1	Grid Points Covering the Study Area	62
4.1	Flow chart for GIS application.	71
4.2	Digital Elevation Model of Jiri sub basin	72
4.3	Digital Elevation Model of Chiri sub basin	73
4.4	Digital Elevation Model of Madhura sub basin	74
4.5	Digital Elevation Model of Ghagra sub basin	75
4.6	Digital Elevation Model of Jatinga sub basin	76
4.7	Drainage network in Jiri sub catchment	78
4.8	Drainage network in Chiri sub catchment	79
4.9	Drainage network in Madhura sub catchment	80
4.10	Drainage network in Ghagra sub catchment	81
4.11	Drainage network in Jatinga sub catchment	82
4.12	Flow direction in Jatinga sub catchment	83

4.13	Drainage network in Katakhal sub catchment	84
4.14	Drainage network in Sonai sub catchment	85
4.15	Slope map for Chiri sub catchment	86
4.16	Slope map for Jiri sub catchment	87
4.17	Slope map for Ghagra sub catchment	88
4.18	Slope map for Madhura sub catchment	89
4.19	Slope map for Jatinga sub catchment	90
4.20	Slope map for Katakhal sub catchment	91
4.21	Slope map for Sonai sub catchment	92
5.1	1 st order watersheds for Madhura	96
5.2	2 nd Order sub-watersheds for Madhura.	97
5.3	2 nd Order sub-watersheds for Madhura.	98
5.4	3 rd Order sub-watersheds for Madhura	99
5.5	4 th Order sub-watersheds for Madhura.	100
5.6	5 th Order sub-watersheds for Madhura.	101
5.7	Madhura watershed (6 th Order).	102
5.8	1 st Order sub-watersheds for Ghagra.	103
5.9	2 nd order sub-watersheds for Ghagra.	104
5.10	3 rd Order sub-watersheds for Ghagra	105
5.11	4 th Order sub-watersheds for Ghagra.	106
5.12	5 th order sub-watersheds for Ghagra.	107
5.13	Ghagra watershed (6 th order).	108
5.14	Selected sub-watersheds for Madhura.	109
5.15	Selected sub-watersheds for Ghagra.	110
5.16	Estimation of ratios R_A, R_B and R_L for MSW_5^1	111
5.17	Estimation of ratios R_A, R_B and R_L for MSW_5^2 .	111
5.18	Estimation of ratios R_A, R_B and R_L for MSW_5^3 .	112
5.19	Estimation of ratios R_A, R_B and R_L for MSW_3^1 .	112
5.20	Estimation of ratios R_A, R_B and R_L for GSW_5^1	113
5.21	Estimation of ratios R_A, R_B and R_L for GSW_5^2 .	113
5.22	Estimation of ratios R_A, R_B and R_L for GSW_4^1	114
5.23	Estimation of ratios R_A, R_B and R_L for GSW_4^2 .	114
5.24	Estimation of ratios R_A, R_B and R_L for GSW_3^1	115
5.25	Estimation of ratios R_A, R_B and R_L for GSW_3^2 .	115
5.26	Figure 5.26: Estimation of ratios R_A, R_B and R_L for GSW_3^3 .	116

5.27	Estimation of ratios R_A, R_B and R_L for GSW_3^4 .	116
5.28	1hr UH for Madhura sub-watershed MSW_5^1 .	120
5.29	1hr UH for Madhura sub-watershed MSW_5^2 .	120
5.30	1hr UH for Madhura sub-watershed MSW_5^3 .	121
5.31	1hr UH for Madhura sub-watershed MSW_3^1 .	121
5.32	1hr UH for Ghagra sub-watershed GSW_5^1 .	122
5.33	1hr UH for Ghagra sub-watershed GSW_5^2 .	122
5.34	1hr UH for Ghagra sub-watershed GSW_4^1 .	123
5.35	1hr UH for Ghagra sub-watershed GSW_4^2 .	123
5.36	1hr UH for Ghagra sub-watershed GSW_3^1 .	124
5.37	1hr UH for Ghagra sub-watershed GSW_3^2 .	124
5.38	1hr UH for Ghagra sub-watershed GSW_3^3 .	125
5.39	1hr UH for Ghagra sub-watershed GSW_3^4 .	125
5.40	1hr UH for Machura watershed.	130
5.41	1hr UH for Ghagra watershed	130
5.42	1hr UH ordinates for Chiri subbasin	132
5.43	1hr UH ordinates for Jiri subbasin	135
5.44	1hr UH ordinates for Jhatinga subbasin	138
5.45	1hr UH ordinates for Sonai Subbasin	140
5.46	1hr UH ordinates for Katakhal subbasin	144
6.1	represents the flood event from 10 th – 17 th July, 2004 at BpGhat.	148
6.2	Represents the flood event from 19 th – 29 th July, 2004 at BpGhat	148
6.3	The flood event from 11 th – 21 st June, 2006 at BpGhat.	148
6.4	Observed and simulated discharge at Annapurnaghat (event-1)	150
6.5	Observed and simulated discharge at Annapurnaghat (event-2)	150
6.6	Observed and simulated discharge at Annapurnaghat (event-3)	151
6.7	Observed and simulated discharge at Badrpurghat (event-1)	151
6.8	Observed and simulated discharge at Badrpurghat (event-2)	152
6.9	Observed and simulated discharge at Badrpurghat (event-3)	152
6.10	Flow at Annapurnaghat: observed flow , safe flow and flow by regulating upstream ungauged catchments flows from Jiri, Chiri and Madhura	167

6.11	Flow at Badarpurghat: observed flow, safe flow and flow by regulating upstream ungauged catchments flows from Jiri, Chiri, Madhura, Jatinga & Ghagra	168
6.12	Flow at Annapurna Ghat (Event-1) including and not including effects of climate change: U/S flow regulation-all catchment	173
6.13	Flow at Annapurna Ghat (Event-2) including and not including effects of climate change: U/S flow regulation-all catchment	174
6.14	Flow at Annapurna Ghat (Event-3) including and not including effects of climate change: U/S flow regulation-all catchment	175
6.15	Flow at Badarpur Ghat (Event-1) including and not including effects of climate change: U/S flow regulation-all catchment	176
6.16	Flow at Badarpur Ghat (Event-2) including and not including effects of climate change: U/S flow regulation-all catchment	177
6.17	Flow at Badarpur Ghat (Event-3) including and not including effects of climate change: U/S flow regulation-all catchment	178
7.1	Observed Sediment Concentration & simulated sediment concentration in upper network	181
7.2	Sediment Concentration at AP Ghat for no sediment flow from Dholai catchments	181
7.3	Observed Sediment and simulated sediment discharge at AP Ghat in upper network	182
7.4	Sediment Discharge at Annapurnaghat for no sediment flow from Dholai	182
7.5	sediment concentration for no sediment flow from Dholai	184
7.6	Sediment concentration for no sediment flow from Madhura,	184
7.7	Observed sediment concentration and concentration at BPghat for no sediment flow from Dholai and Madhura subcatchments	185
7.8	Sediment discharge for no sediment flow from Matijuri	185
7.9	Sediment discharge for no sediment flow from Matijuri and Dholai subcatchments.	186
8.1	Observed, estimated and 2 hours ahead forecasts of downstream flow rates at Badarpurghat	191
8.2	Observed, estimated and 2 hours ahead forecasts of downstream flow top width at Badarpurghat	191

List of Tables:

Table No	Particulars	Page no
1.1	Details of Major Tributaries of River Barak in the study area	4
2.1	Flow area Details of Barak River system	12
2.2	Flow area Details of Jiri River system	22
2.3	Flow area Details of Ciri River system	25
2.4	Flow area Details of Sonai River system	28
2.5	Flow area Details of Badri River system	34
2.6	Flow area Details of Madhura River system	37
2.7	Flow area Details of jatinga River system	40
2.8	Flow area Details of Gagra River system	43
2.9	Flow area Details of Katakhal River system	48
2.10	Flow area Details of Longai River system	53
2.11	Details of existing embankment in the study area	59
2.12	Details of existing major sluice gates in Barak Valley	60
3.1	Rainfall gauging station in the selected Grids	63
3.2	Estimated T-year rainfall intensity for Barak Valley	67
3.3	Estimation of mean rainfall using regional mean relationship	68
4.1	Table-4.1 basins in the Study Area	93
5.1	Geomorphologic characteristics of sub watersheds of Ghagra and Madhura	117
5.2	Morphological parameters for the subcatchments	117
5.3	1hr UH ordinates for MSW_5^3 .	118
5.4	1hr UH ordinates for GSW_5^1 .	119
5.5	Unit Hydrograph characteristics for the sub-watersheds.	126
5.6	Channel characteristics and parameters.	127
5.7	Routing parameters for sub-watersheds.	127
5.8	Morphological parameters and IUH Characteristics of sub basins	129
5.9	1hr UH ordinates for Chiri subbasin	131
5.10	1hr UH ordinates for Jiri subbasin.	132
5.11	1hr UH ordinates for Jatinga subbasin.	135
5.12	1hr UH ordinates for Sonai subbasin.	138
5.13	1hr UH ordinates for Katakhal subbasin.	140
6.1	Stage-Discharge Relationships for various gauging stations:	145
6.2	Details of the flood Events used in the study	146
6.3	Estimated parameter for the upper network having outflow at Annapurnaghat	149

6.4	Estimated parameter for the complete River Network having outflow at Badarpurghat	149
6.5	Peak flow improvement at Annapurnaghat for restricting flow from single upstream catchment completely (EVENT 1: FROM 10-JULY TO 17 JULY-2004)	154
6.6	Peak flow improvement at Annapurnaghat for restricting flow from two upstream catchments completely (EVENT 1: FROM 10-JULY TO 17 JULY-2004)	155
6.7	Peak flow improvement at BadarpurGhatfor restricting flow from single upstream catchment completely (EVENT 1: FROM 10-JULY TO 17 JULY-2004)	156
6.8	: Peak flow improvement at BadarpurGhat for restricting flow from two upstream catchments completely (EVENT 1: FROM 10-JULY TO 17 JULY-2004	157
6.9	Peak flow improvement (Average) at Annapurnaghat for restricting flow from single upstream catchment completely	158
6.10	Peak flow improvement (Average) at Annapurnaghat for restricting flow from two upstream catchment completely)	159
6.11	Peak flow improvement (Average) at BadarpurGhat for restricting flow from single upstream catchment completely	160
6.12	Peak flow improvement (Average) at BadarpurGhat for restricting flow from two upstream catchment completely	161
6.13	Flood events used in the study	163
6.14	Percentage reduction in peak flow rates in upstream ungauged catchments required to create safe flow at Annapurnaghat	165
6.15	Percentage reduction in peak flow rates in upstream ungauged catchments required to create safe flow at BadarpurGhat	165
6.16	Regulated Peak flow rates for the ungauged catchments upstream of Annapurnaghat (upto Lakshipur) that creates safe flow at Annapurnaghat	165
6.17	Regulated Peak flow rates for the ungauged catchments upstream of Badarpurghat (upto Lakshipur) that creates safe flow at Badarpurghat.	166
6.18	Peak flow rates for the gauged and ungauged regulated catchments upstream of Annapurnaghat (upto Lakshipur) with no regulation of flow in the main channel necessary to create safe flow at Annapurnaghat including and not including effects of climate change	170
6.19	Peak flow rates for the gauged and ungauged regulated catchments upstream of Badarpurghat (upto Lakshipur) with no regulation of flow in the main channel necessary to create safe flow at Badarpurghat including and not including effects of climate change	171

Flood Damage Mitigation: Report

7.1	Model Parameters for Upper Network	180
7.2	Model parameters for complete River system	183
7.3	Impact of sediment flow from upstream catchments at Badarpurghat	186
7.4	Impact of sediment flow from upstream catchments at Annapurnaghat	187
8.1	Hybrid multiple inflows Muskingum model performances	190

FLOOD DAMAGE MITIGATION MEASURES FOR BARAK VALLEY IN SOUTH ASSAM INCLUDING EFFECTS OF CLIMATE CHANGE

Abstract: In the present study attempt has been made to determine the extent of flow regulations required in the upstream catchments to have safe flow at important downstream damage locations in Barak river system. There are a number of gauged and ungauged catchments in the study area and downstream flow simulation model incorporating flows from all the upstream gauged and ungauged catchments have been developed for the river system. To determine the existing flow capacity of the sections in the tributary river systems as well as in the main river the sections are surveyed at a regular interval and at all critical sections along a river course and the required channel parameters and other sectional details such as flow area, top width etc are determined/computed. Expected maximum rainfall intensity for different return periods for the study area is obtained by applying L-moment techniques for the homogeneous zone identified by applying fuzzy C-means based clustering techniques.

Three flood events considering availability of rainfall records in the study area are selected and used to conduct flood movement analysis for the river system. Stage-discharge relationships for all gauging stations are developed applying regression technique and are used to express the flow depths measured at a gauging station in terms of the discharge value. Flow contributions from the ungauged catchments are obtained by using GIUH approach. Important morphological parameters for the tributary river systems required for developing the GIUH models are derived using the DEM, stream network, slope map and data obtained by direct field measurements. The IUHs obtained for the catchments are lagged using s-curve technique to derive 1-hour unit hydrograph. Contributions from the important ungauged catchments are determined by using 1-hour unit hydrograph for the catchment and the rainfall excess for the storm events during the selected flood periods. Flow contributions from the gauged and ungauged catchments are integrated using equivalent inflow for a number of

upstream flows applicable to the river networks in the study area. Sediment flow simulation model for the river system are developed using the sediment concentration and sediment discharge data collected for the river system. The model is used to assess the relative contributions of the catchments in sediment load in the river reaches. Downstream flow rate and flow top width forecasting models have been developed for the river system that can be applied to forecast downstream flow conditions well in advance on the basis of upstream flow rates recorded at several upstream sections. Linear Programming model is formulated for the river networks having outflow at Annapurnaghat and Badarpurghat to determine effects of upstream flows on the downstream flows. The model is applied for two cases: (i) when upstream flows from the major ungauged catchments are regulated (ii) when flows from all upstream catchments are regulated. The effects of climate change on the flow rates are incorporated in the LP model and for the changed climatic conditions flow controls required in all major catchments upstream of the potential damage sections at Annapurnaghat and Badarpurghat are evaluated. Based on the survey works, field trips and laboratory works conducted to asses existing flow capacity of the channel systems, functioning of the sluice gates in the districts of Cachar, Karimjang and Hailakandi and status of existing embankments along the river courses etc. some observations/recommendations are forwarded that may be considered for further study and / implementation for improving overall flood condition in the valley

1.0 Introduction:

The Barak river system is the second largest system in the North Eastern region of India and falls within hydro meteorological sub zone, 2c of India. The river system drains 26,193 Sq. Km in India with approximately 6562 Sq. Km from the state of Assam. The area is quite undeveloped compared to other parts of India. The main river Barak receives a large number of minor tributaries and 20 major tributaries out of which 12 are wholly in India. Flood and erosion problems in Barak valley is a major cause of concern, every year there is colossal flood losses in the valley. The GOI is considering various steps for alleviating the problem of natural disasters like flood, and landslide in this area.

The main river Barak has an approximate length of 900 km out of which 532 km is in India and nearly 129 km is in the state of Assam. The valley has an average width of 25-30 km and is situated in the route of south-west monsoon. Highest annual rainfall for the valley= 4194 mm recorded at Silchar in 1989. Maximum discharge for the Barak river system= 7786.08 m^3/s recorded at Badarpur in 1976. As per available records, nearly 3.50 lakh hectares of land area in the valley is flood prone and some protection against flood damages is available to 57% of the flood prone areas only. There are 26 nos of major sluice gates in the valley and approximately 738 km long embankments along the main river and its tributaries exist to help reduce the impact of flood. But, as most part of these embankments has outlived the life span the embankments develop large breaches regularly during monsoon seasons causing huge flood damages.

Some of the main factors that acting singly or in combination causes flood in the valley are:

- (i) High incidence of rainfall, (ii) Deforestation in the upper catchments (iii) Inadequate natural drainage system (iii) Reduction in natural reservoirs (iv) Heavy encroachment in the riverine area (v) Large scale construction activities without proper planning

To improve flood scenario reducing flood related losses in the valley it is imperative that some actions be initiated against the controllable factors mentioned above. Some of the recommendations may be construction of embankments in the existing gap positions, raising heights of the existing embankments, afforestation in the upper catchments and adoption of suitable watershed management plans to reduce sediment load in the channels. To tackle flood problems in the valley solution is to be achieved incorporating due weightage to all hydrologic and hydraulic factors effecting flood movement in the river system. A comprehensive and integrated mitigation plan should be prepared based on the hydraulic, hydrologic factors and local conditions of natural reservoirs, drainage system etc. In the present study different possible measures for mitigating flood damage in the Barak valley comprising three districts namely, Cachar, Karimganj and Hailakandi using available and generated hydrologic and hydraulic information on the study area is investigated. The study is aimed at evaluating effects of different sub catchments on the downstream flood scenarios at important locations, namely at Annapurnaghat and at Badrapurghat for different possible actions in the upstream catchments and river reaches. To formulate comprehensive flood damage mitigation plan investigations that need to be conducted under the study are: - examination of (i) existing flow capacity for different channels in the system, (ii) Adequacy of existing embankments and sluice gates (iii) Sediment load in the river system and erosion potential of different sub catchments and (iv) Development of an efficient tool for improved flood forecasting incorporating flow contribution from gauged and ungauged catchments in the river system and (v) Assessment of effects of climate change on flood flow in the river system.

1.1 Study Area and Data Used

In the present report investigation works conducted for recommending suitable flood damage mitigation measures for Barak valley with the main river running from Phulertal at Lakhipur to international boarder point in Karimganj district along with study results and findings are presented. The main river reach from Lakhipur to Karimganj town receives a number of

medium and small tributaries as shown in Map of the study area given in figure 1(a) and figure 1 (b). A few of the tributaries in the study area are gauged while, the rest are ungauged for which pertinent hydrologic and hydraulic information required for flow and erosion modeling are not available. Details of the major and minor tributaries joining the main river Barak from Fulertal at Lakhipur to Bangladesh border at Karimjanj district are given in Table-1. River flow and stage data for different gauging stations in the study for the period 2000-2010 are collected from CWC, Shillong. The collected stage and corresponding flow data for different river sections are used to develop stage vs discharge relationships for the gauging stations. Using recorded hourly stage/flow value for different sections downstream flow simulation models for the study area are developed. Hourly rainfall intensity records for different raining gauging stations in Barak valley are collected from RMC Guwahati. The rainfall values are used to compute runoff from the ungauged catchments during the selected storm events; annual maximum rainfall records for different stations is used to determine expected maximum rainfall intensity for different return periods in the study area. Daily sediment discharge versus water discharge data are collected from CWC Shillong for the period 2000-2010. The collected data are used to develop Sediment routing model for the river system.

1.2 Watershed Data:

To accomplish the proposed investigations pertinent data for the gauged and ungauged catchments are extracted using Geographic information system (GIS). GIS technique is utilized to develop digital elevation models (DEM), slope map, drainage maps for different sub watershed. Features and characteristics of the sub basin extracted applying GIS technique are utilized for developing rainfall-runoff model by applying Geomorphic Instantaneous Unit Hydrograph (GIUH) technique. The DEMs are developed using Survey of India Topo Maps in 1:50000 scales obtained from SOI, Shillong office. The 1-hr unit hydrograph developed for the important ungauged catchments in the study area are used to compute direct runoff hydrograph for these catchments for a set of identified storm events during the period 2000-2010.

1.3 River Networks

The Barak river network in the study area that drains three districts in the valley: Cachar, Karimganj and Hailakandi districts is segmented into a upper network and a lower river network. The upper network terminates at *the* downstream gauging station at AnnapurnaGhat in the River Barak and *receives* flows from the upstream ungauged sub catchments of *Jiri,, Chiri , Madhura and gauged subcatchments of Dholai and Maniarkhal apart from the upstream flows gauged at Fulertal in Barak at Lakhipur*. The lower network consists of the main river Barak from the upstream point at Annapurnaghat to the downstream point at Badarpurghat. The downstream flow at Badarpurghat is due to the inflow at Annapurnaghat, flows from the ungauged subcatchments *Jatinga, Ghagra* and flow from the tributary Katakhal with gauging station at *Matijuri*. To simulate and forecast water and sediment discharge at two important downstream locations namely, Barak at AnnapurnaGhat, near Silchar town and Barak at BadarpurGhat near Badarpur in Karimganj District water and sediment discharge simulation and forecasting models for the upper network with downstream station at AnnapurnaGhat and for the complete river network with Badarpurghat as the downstream station are developed.

TABLE 1.1 Details of Major Tributaries of River Barak in the study area

<i>Name of the main River</i>	Left Bank/Right Bank Tributary	Confluence (District)
<i>Jiri</i>	Right	Cachar
<i>Chiri</i>	Right	Cachar
<i>Sonai</i>	Left	Cachar
<i>Badri</i>	Right	Cachar
<i>Madhura</i>	Right	Cachar
<i>Ghagra</i>	Left	Cachar
<i>Dhaleshwari</i>	Left	Cachar
<i>Katakhal</i>	Left	Hailakandi
<i>Jatinga</i>	Right	Cachar
<i>Longai</i>	Left	Karimganj
<i>Ghumra</i>	Right	Cachar



FIGURE 1.1 Ariel map of the study area

1.4 Objectives of the present study:

The major objectives of the present work are to study effectiveness of the existing flood control measures in Barak valley and to recommend suitable measures for mitigating flood damages. Following are the major objectives of the present study

- (i) Assessment of existing flow capacity for different channels in the river system.
- (ii) Assessment of effectiveness of existing embankments in the study area
- (iii) Improvement works for lateral channels and natural reservoirs
- (iv) Investigation on sediment load in the river system and erosion potential for different sub catchments.
- (v) Evaluation of impacts of flows from upstream catchments on downstream flood flows
- (vi) Development of an improved flood forecasting tool for the study area incorporating flow contribution from gauged and ungauged catchments
- (vii) Evaluation of effects of climate change on flood flows in the river system.

Flow Chart depicting development of flood damage mitigation plan for the study area consisting of three districts in south Assam, Cachar, Karimganj and Hailakandi is presented in the figure given next

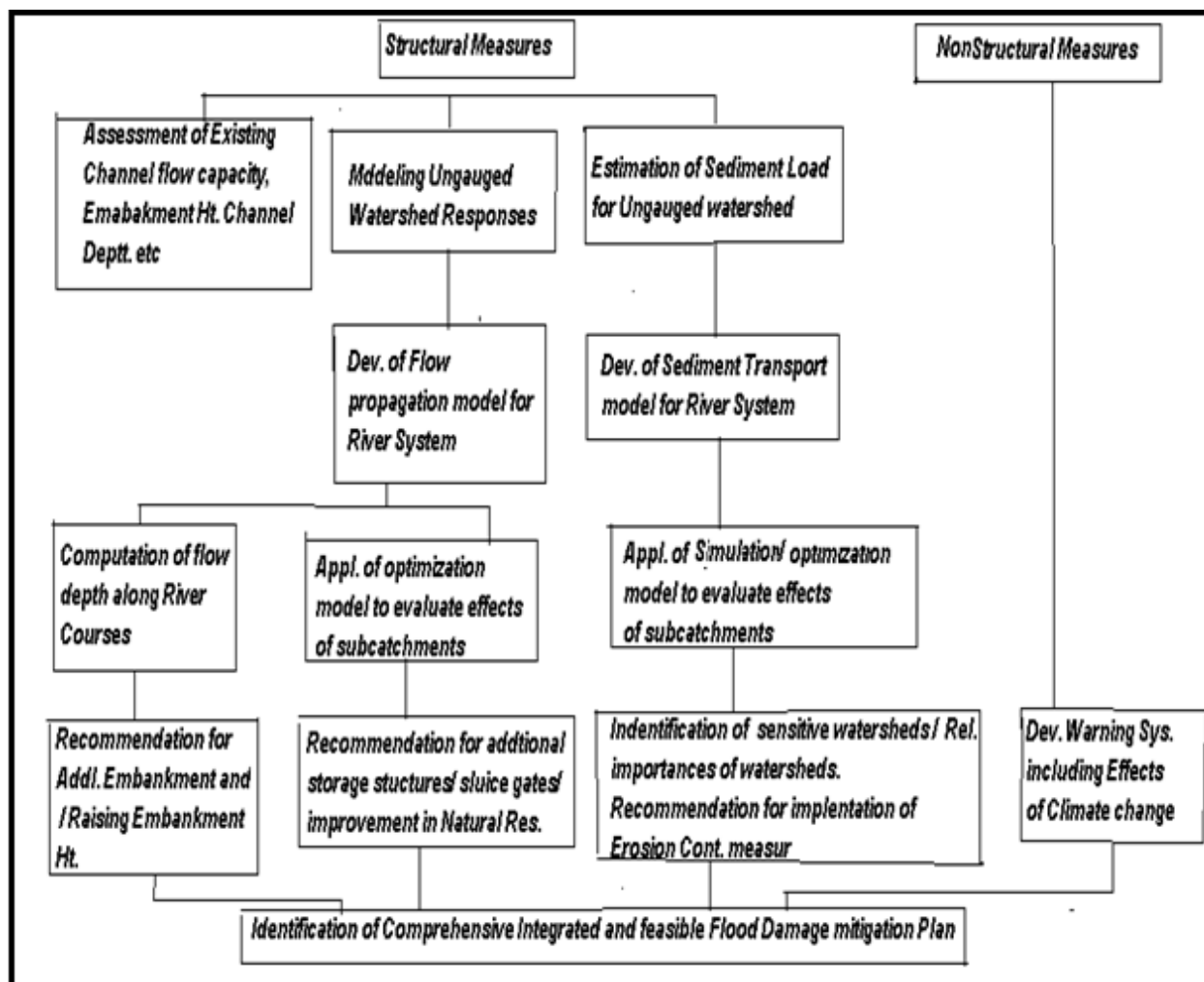

1.5 Outline of the present study

To achieve the above mentioned goals following field and laboratory works have been conducted.

- I) Survey of main channel Barak from Lakhipur to Bangladesh border point near Badarpur in Karimganj District and survey of all important tributary channel systems to determine existing flow capacity and other important channel parameters.
- II) Study of existing embankments along the main course upto International border with Bangladesh from Lakhipur and along the major tributary river systems.
- III) Development of Stage- Discharge relationship for the gauging stations in the study area.

- IV) Estimation of T-year rainfall intensity for the study area by applying L-moment techniques.
- V) Development of Slope Map, Drainage Map, Digital Elevation models for important subcatchments in the study area and extraction of geomorphologic parameters, hydraulic and channel parameters by using Geographic Information System (GIS)
- VI) Development of 1-hr unit hydrograph for the ungauged sub catchments in the study area
- VII) Development and application of flow routing models for the upper network and the complete river network in the study area to simulate flood flow rates at Annapurnaghat near Silchar and Badarpurghat near Badarpur in Karimganj district.
- VIII) Development and applications of sediment flow routing model to simulate downstream sediment discharge and sediment concentration at important downstream locations and assessment of relative effects of erosion from different sub catchments.
- IX) Formulation and applications of optimization models to assess impacts of flows from different sub catchment on downstream flood flows and to evaluate suitable control measures for protecting the important downstream locations.
- X) Development of flow forecasting model to forecast common downstream flows on the basis of upstream flows/ river stages.
- XI) Development of Climate change module to evaluate effects of climate change on flood flow in the study area and to recommend suitable control measures under the changed scenarios.

Detailed description of the studies conducted to achieve the targets is presented in the subsequent sections and subsections.

2.0 Assessment of Flow Capacity of Different Channels in the River System in Barak Valley

2.1 Main Channel: River Barak

To assess flow capacity of the main channel Barak from Lakhipur in Assam, India up to international border with Bangladesh various data and maps available with the department of water resources, GOA have been utilized. Digital data and images collected from NRSA are used with GIS technique to identify critical and vulnerable channel locations; to extract different morphometric and geomorphologic characteristics of the channel system such as, length, slope, areas etc and to estimate channel width at different locations. On the basis of preliminary assessment made using digital images field measurements for flow depth, cross sectional areas, flow velocity etc. have been undertaken at the identified and other critical location to estimate existing flow capacity for the channels in the river system. The main river course from Lakhipur to Badarpurghat have been surveyed to assess channel flow capacity at an interval of 2 km approximately covering critical locations such as sharp bend, narrow widths etc. M/S M.S Survey, Hoogly, Kolkata was entrusted to job of survey works. The agency surveyed the main river course in two parts and covered the channel stretch upto international border with Bangladesh. Some representative survey details of the main river is included in the following sections and full details submitted by the agency is sent separately along with this report.

2.2 Tributary River Systems:

The important tributary channel systems that have been surveyed to estimate flow capacity and other pertinent details includes the right bank tributaries, Jiri, Chiri, Badri, Madhura and Jhatinga and the left bank tributaries Sonai, Ghagra, Katakhal and Longai. A team of technical and non-technical staff from the department of Civil Engineering completed the survey works of the important tributary channel systems in the study area. Relevant section details of the tributary drainage systems such as top width, maximum flow depth, average flow area etc. at a regular interval and at all critical locations are obtained by direct measurement and / laboratory computation. The detailed description of the tributary river system along with pertinent details is presented subsequently.

2.3 Details of Existing Embankments and Sluice Gates in the Study Area:

The survey team traversed through the river network in the study area collected details of the existing embankments along the main river and along the tributaries. Details of existing sluice gates in the subcatchments as well as existing water bodies were also recorded /measured by the team. Distance of the existing embankments from the central axis of the river course, height of the embankment, length of the embankment etc have been measured/computed for the entire river networks. Details of the embankments along the main river course from Lakhipur to Bhanga in Karimganj district and along the tributary channels in the major sub catchments are as follows: flow areas of section along the river courses in the valley are presented in Tables 2.1 through 2.10; map of the river courses and section details are given in figures 2.1 through figures 2.20(c); Details of existing embankment along the major tributary river systems and along the main river Barak is given in Table-2.21 and list of the existing major sluice gates in the study area is available in Table-2.12

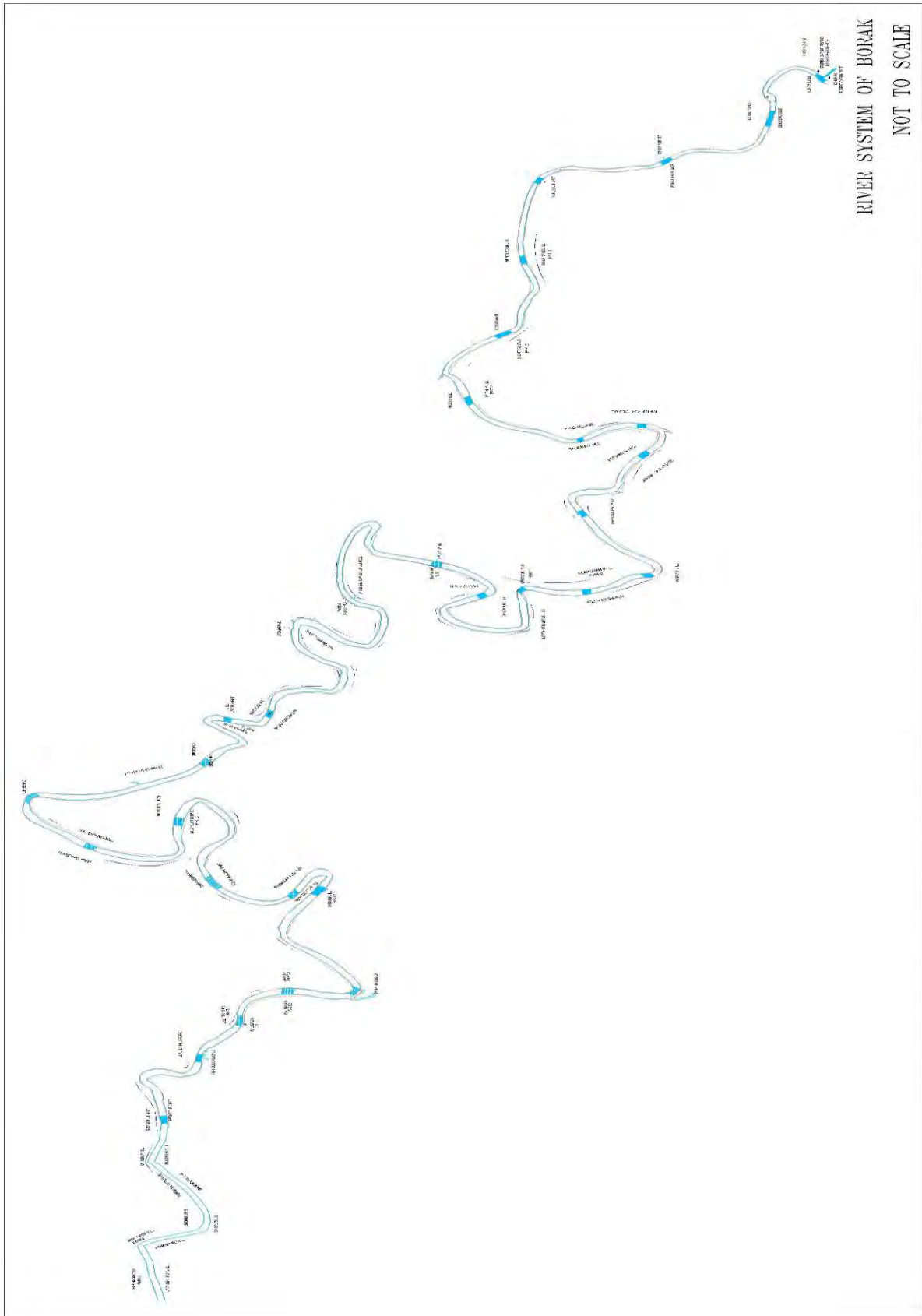

Fig 2.1 : Main River Borak from Lakhipur to Bhanga (upto Bangladesh Border):

Flood Damage Mitigation: Report

TABLE 2.1 Flow area Details of Barak River system (Jiri Muk to Bangha)

Sl. No	Ch	Top Width (m)	Average Depth (m)	Maximum Depth (m)	Safe Flow Area (Sq.m)	Dist. Between station	Embankment Details (Distance from central line; Height in metre)		Remarks	
							Left Bank	Right Bank	Left Bank	Right Bank
1	0	250.00	11.842	15.818	3835.250	0.000	Nil	Nil	Hill	Forest
2	4	261.50	16.151	23.033	3785.130	4.000	Nil	Nil	Forest	Forest
3	8	215.00	11.529	11.495	2457.930	4.000	Nil	Nil	Village/hill/Pineapple garden	Forest
4	12	220.85	12.727	17.445	2787.688	4.000	Nil	Nil	Residential Area	Residential Area
5	16	212.48	10.589	13.086	1983.738	4.000	D= 90.00 , H = 2.50	Nil	Agriculture Land	Agriculture Land
6	20	234.94	11.76	15.868	2682.150	4.000	D = 70.00 , H = 3.00	Nil	Paddy Land	Paddy Land
7	24	255.10	10.18	14.67	2544.010	4.000	D = 192.00 , H = 3.20	Nil	Paddy Land	Paddy Land
8	28	200.86	8.729	18.803	1724.126	4.000	D = 344.00 , H = 3.00	Nil	Paddy Land	Residential Area/Paddy land
9	30	263.27	8.378	16.31	1859.470	2.000	D= 353.00 , H = 2.50	Nil	Hut/Residential Area	Paddy Land
10	32	306.27	7.516	12.278	2199.628	2.000	D= 321.00 , H = 2.00	D = 40.00 , H = 2.90	Agriculture Land	Agriculture Land
11	36	201.95	9.736	13.286	1999.194	4.000	D = 1 Km , H = 3.00	D= 210.00 , H = 3.10	Agriculture Land	Residential Area
12	40	273.48	7.056	14.078	1930.570	4.000	D = 265.00 , H = 2.70	D = 850.00 , H = 3.20	Paddy Land/Village	Agriculture Land
13	42	287.00	8.164	13.662	2361.694	2.000	D= 220.00 , H = 3.00	D = 650.00 , H = 3.10	Agriculture Land	Agriculture Land
14	44	215.40	11.39	25.936	2332.043	2.000	D = 183.00 , H = 2.70	D = 85.00 , H = 3.20	Paddy Land	Vill/Paddy Land
15	46	208.21	10.519	18.839	2291.650	2.000	D= 30.00 , H = 2.90	Nil	Residential Area	Vill/Paddy Land
16	50	259.93	10.871	10.871	2675.210	4.000	Nil	D = 1 KM , H = 3.20	Vill/Paddy Land	Agriculture Land
17	53	258.94	8.85	16.17	2237.346	3.000	D = 129.00 , H = 3.00	D = 440.00 , H = 3.10	Paddy Land	Paddy Land
18	60	207.6	9.613	15.852	1998.14	7.000	D= 10.00 , H = 1.80	D= 280.00 , H = 3.00	Residential Area	Residential Area

Flood Damage Mitigation: Report

TABLE 2.1 Contd. (Jiri Muk to Bangha)

Sl. No	Ch	Top Width (m)	Average Depth (m)	Maximum Depth (m)	Safe Flow area (Sq.m)	Dist. Between station	Embankment Details (Distance from central line; Height in metre)		Remarks	
							Left Bank	Right Bank	Left Bank	Right Bank
19	66	221.65	12.596	23.087	2788.289	6.000	D= 40.00 , H = 2.90	D = 192.00 , H = 2.60	Village	Village
20	69	190.7	13.02	25.415	2526.145	3.000	D = 4.00 , H = 2.20	D = 560.00 , H = 2.90	Residential Area	Residential Area
21	72	254.36	8.032	12.65	2680.89	3.000	D= 96.00 , H = 1.50	D= 180.00 , H = 2.00	Paddy Land	Paddy Land
22	74	234.04	11.48	18.65	2676.366	2.000	Nil	D = 314.00 , H = 2.80	Residential Area	Paddy Land
23	77	283.14	5.564	15.037	2377.168	3.000	D= 186.00 , H = 2.90	Nil	Residential Area	Paddy Land
24	80	265.73	8.563	12.602	2218.328	3.000	D = 160 km , H = 3.00	Nil	Residential Area/Paddy land	Residential Area/Paddy land
25	83	235.39	10.714	14.832	2430.426	3.000	D = 1.2 km , H = 3.20	Nil	Paddy Land	Vill/Paddy Land
26	86	243.74	8.123	13.912	2025.81	3.000	D = 185.00 , H = 3.30	D = 194.00 , H = 2.90	Residential Area	Residential Area
27	90	345.27	7.428	11.425	2450.537	4.000	D = 28.00, H = 3.00	D = 25.00 , H =3.00	Residential Area	Residential Area
28	97	249.17	9.896	15.139	2430.551	7.000	D = 360.00 , H = 3.20	D= 48.00 , H = 2.70	Paddy Land	Residential Area
29	100	255.43	10.025	14.972	2522.875	3.000	D = 289.00 , H = 2.90	Nil	Agriculture Land/Vill	Agriculture Land/Vill
30	102	288.54	11.158	15.656	3265.021	2.000	Nil	Nil	Paddy Land	Paddy Land
31	108	224.19	12.67	22.879	2753.388	6.000	Nil	D = 680.00 , H = 3.00	Paddy Land	Paddy Land
32	110	394.04	6.572	11.317	2426.054	2.000	Nil	D = 110.00 , H = 2.85	Paddy Land	Residential Area/Paddy land

Flood Damage Mitigation: Report

TABLE 2.1 Contd.(Jiri Muk to Bangha)

Sl. No	Ch	Top Width (m)	Average Depth (m)	Maximum Depth (m)	Safe Flow area (Sq.m)	Dist. Between station	Embankment Details (Distance from central line; Height in metre)		Remarks	
							Left Bank	Right Bank	Left Bank	Right Bank
33	112	224.31	9.395	13.326	2242.05	2.000	Nil	D = 390.00 , H = 2.50	Paddy Land	Agriculture Land/Paddy land
34	115	189.26	10.346	13.243	1981.264	3.000	Nil	D= 12.00 , H = 2.90	Paddy Land	Paddy Land
35	119	227.87	12.462	16.962	3002.5	4.000	Nil	D = 65.00 , H = 1.70	Vill/Paddy Land	Residential Area
36	120.3	417.45	9.58	16.50	4550.40	1.30	Nil	D = 75.00 , H = 1.50	Residential Area	Paddy Land
37	123	321.80	12.22	18.21	4151.87	2.70	Nil	D = 163 , H = 1.70	Residential Area	Residential Area
38	126.5	362.74	8.28	12.34	3143.27	3.50	Nil	Nil	Paddy Land	Paddy Land

Flood Damage Mitigation: Report

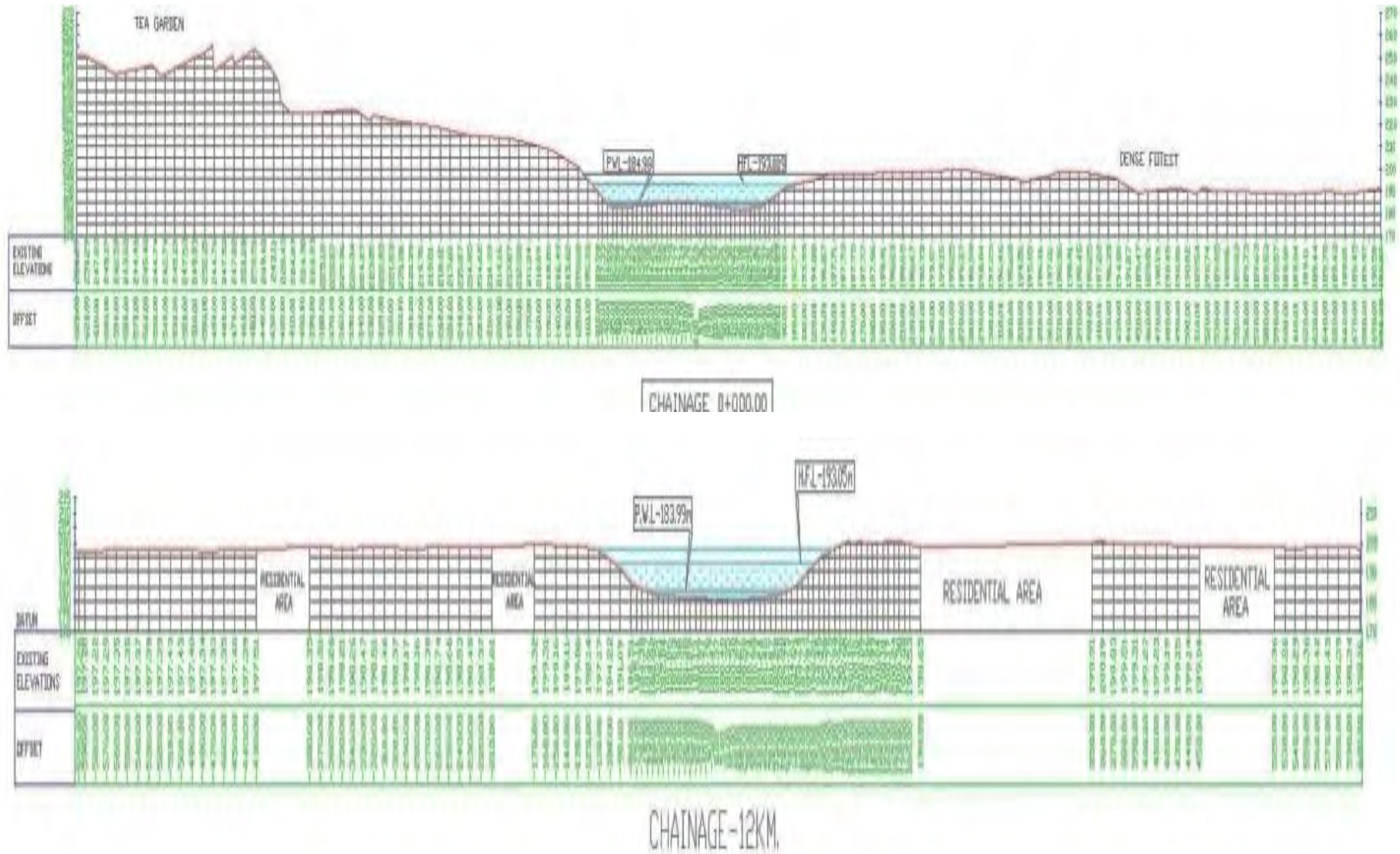

FIGURE 2.2(a) Section Details of Barak River upto 500m in the countryside

Flood Damage Mitigation: Report

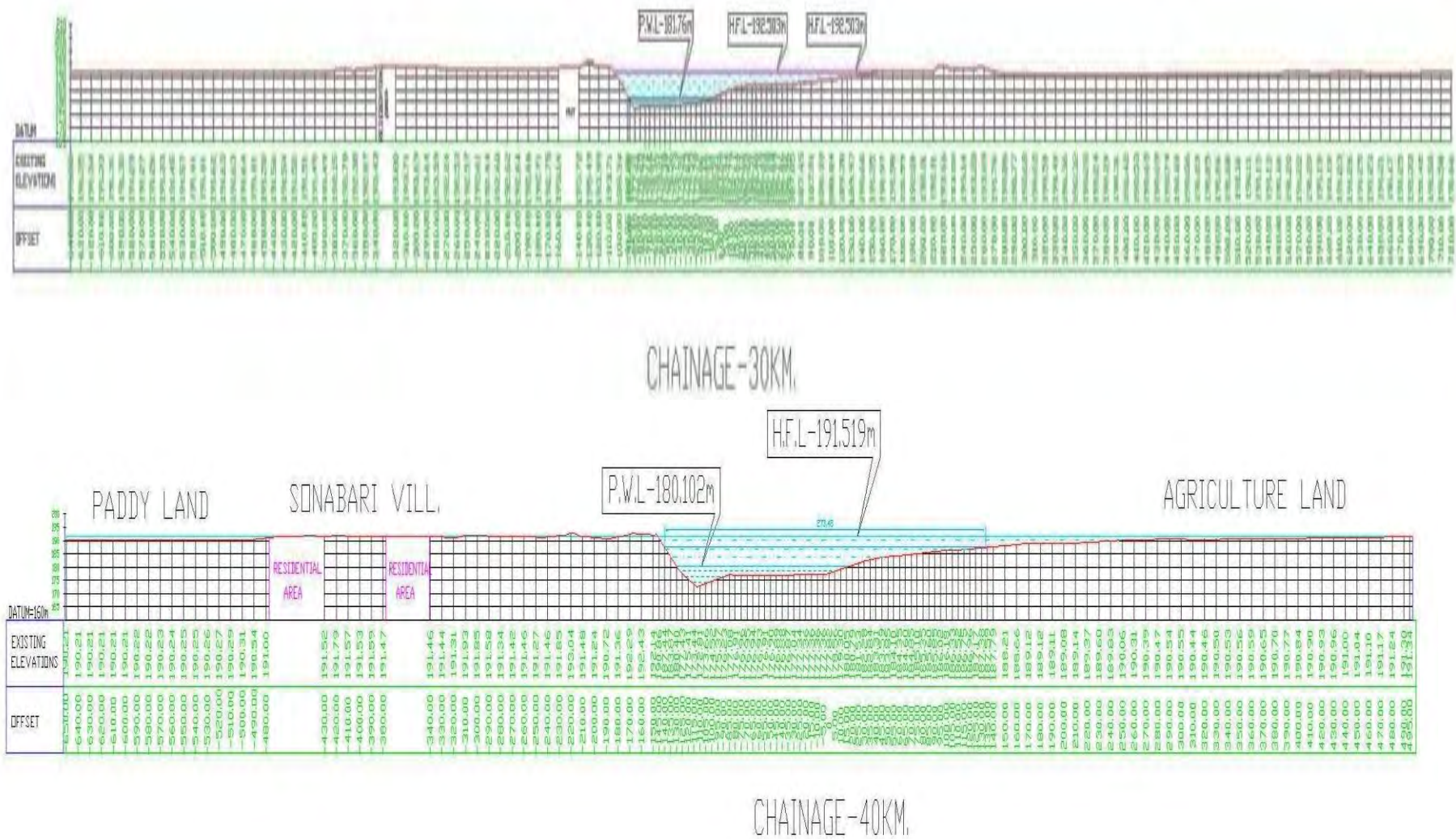

FIGURE 2.2(b) Section Details of Barak River upto 500m in the countryside

Flood Damage Mitigation: Report

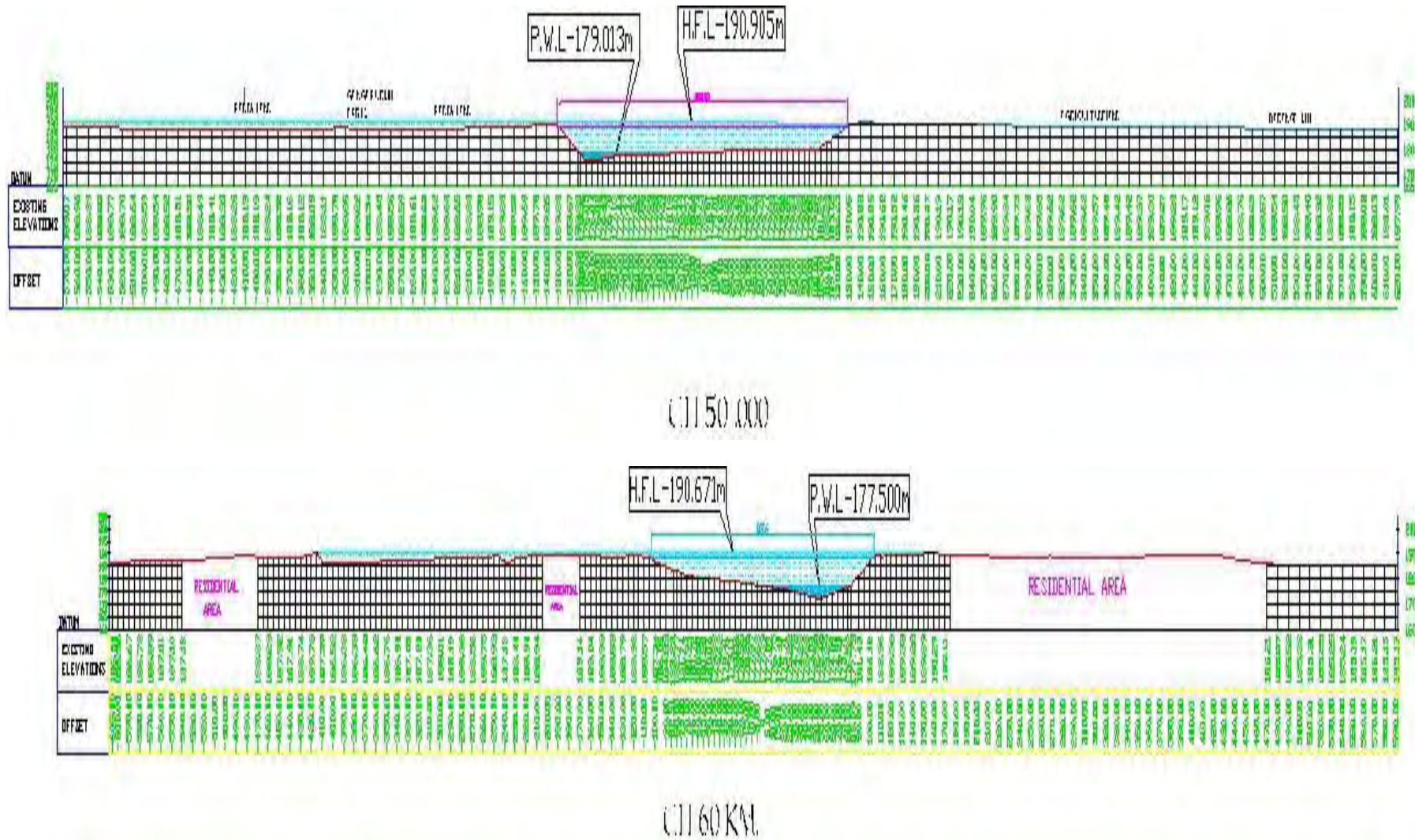

FIGURE 2.2(c) Section Details of Barak River upto 500m in the countryside

Flood Damage Mitigation: Report

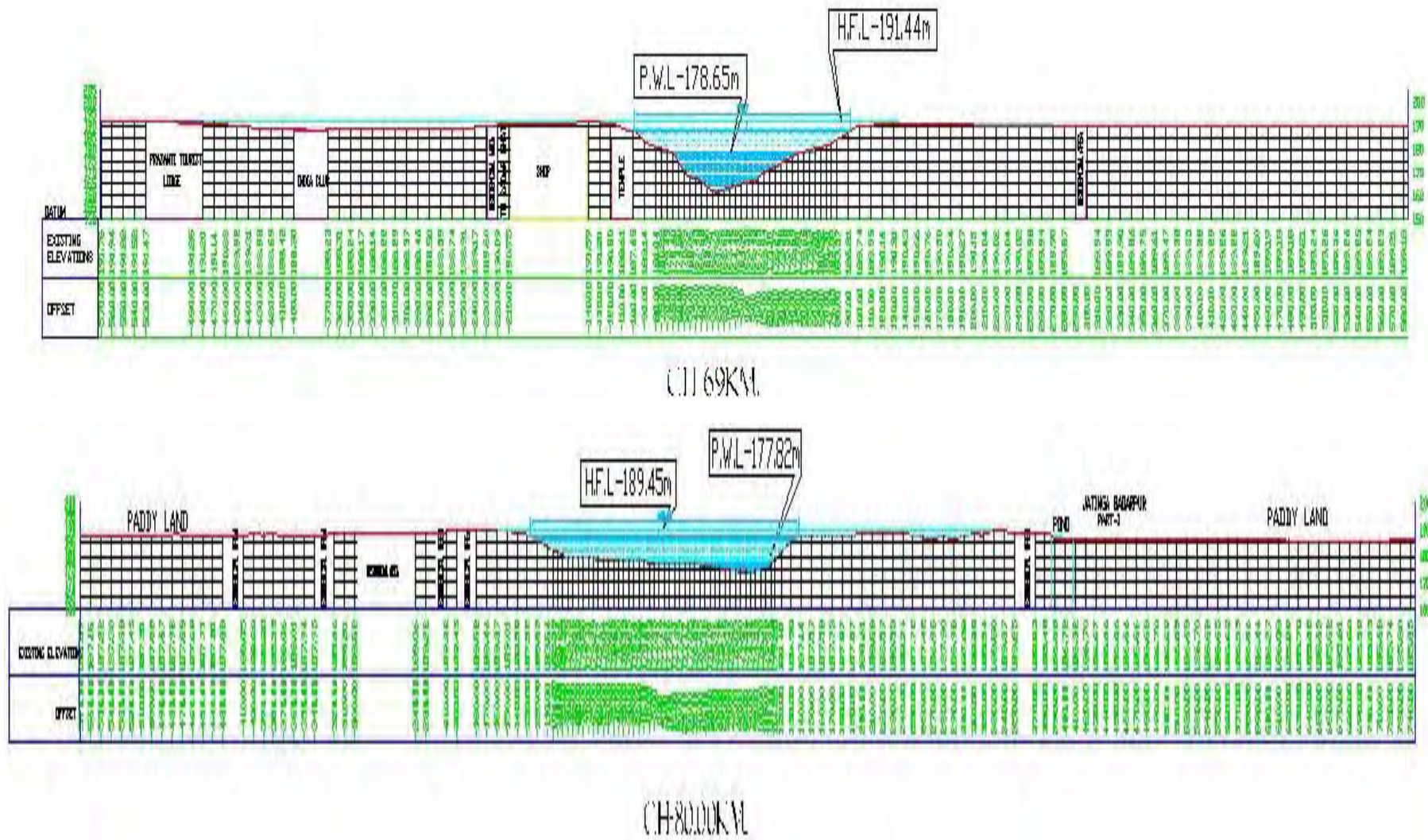

FIGURE 2.2(d) Section Details of Barak River upto 500m in the countryside

Flood Damage Mitigation: Report

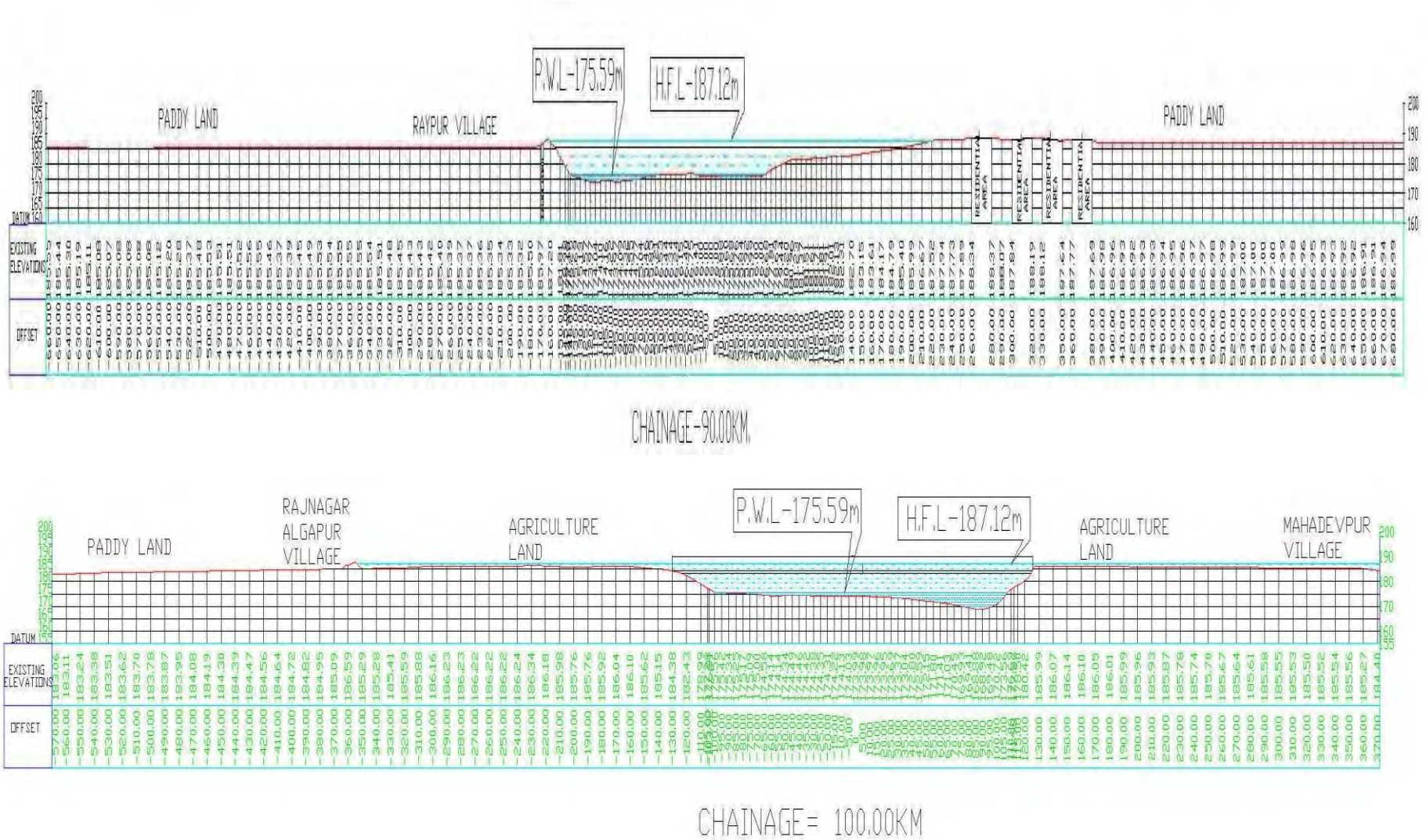

FIGURE 2.2(e) Section Details of Barak River upto 500m in the countryside

Flood Damage Mitigation: Report

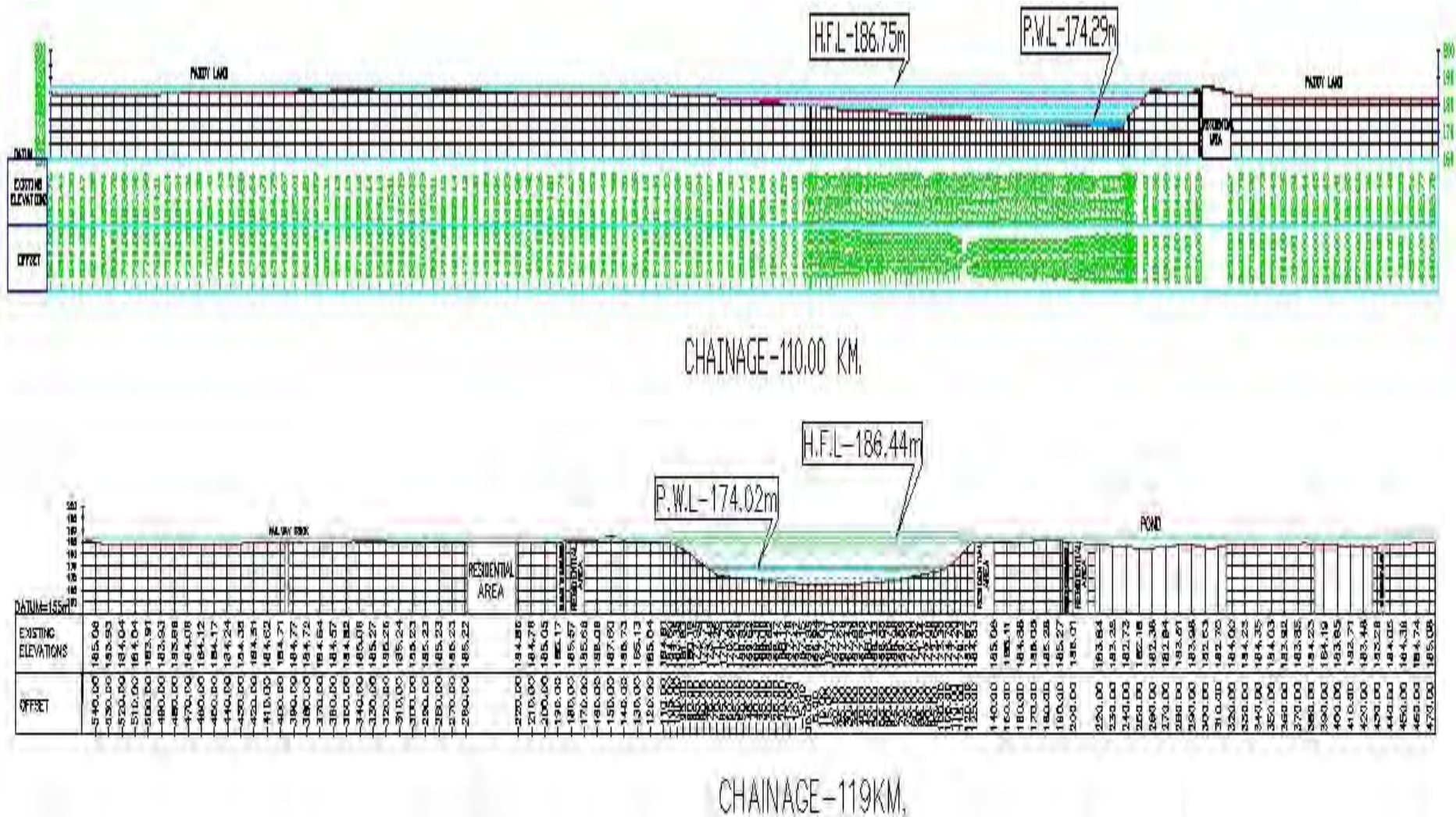

FIGURE 2.2(f) Section Details of Barak River upto 500m in the countryside

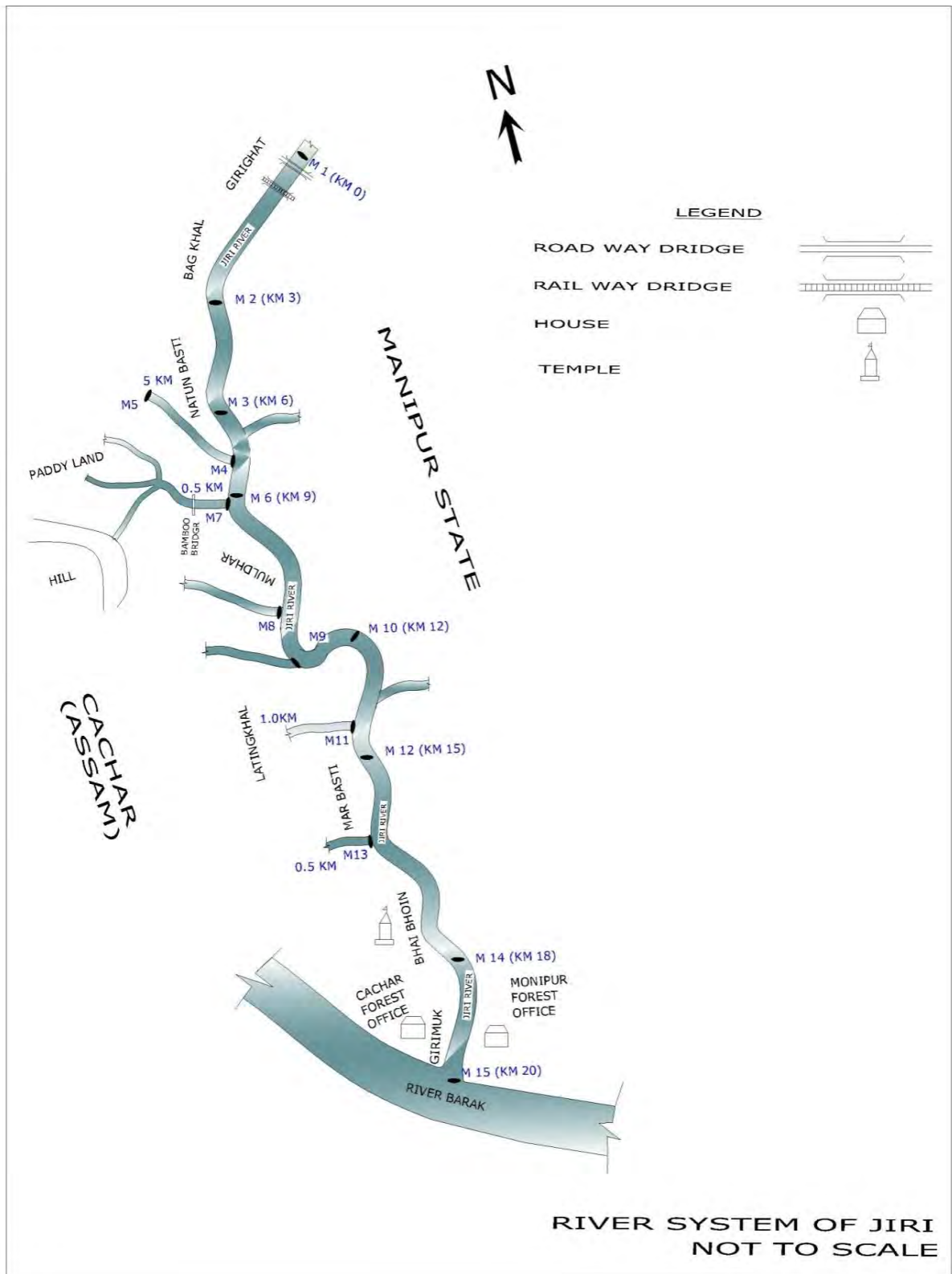

FIGURE 2.3 Name of the sub water shed:-Jiri, Approximate catchment Area: 1052.85 km²

TABLE 2.2 Flow area Details of Jiri River system

Maximum Top width = 113.05 m

Average Top width = 55.65 m

Name of station	Distance from confluence point with Barak in kM(Approx)	Maximum top width (T) in (M)	Vertical depth (m)					Maximum depth(m)	Flow area (Approx) in Sq.m	Embankment details	
			1/6.T	2/6.T	3/6.T	4/6.T	5/6.T			R Bank	L Bank
MS 1	20.00	83.20	5.40	7.50	10.80	12.60	9.50	12.60	165.11	Nil	Nil
MS 2	17.00	99.10	6.30	7.65	8.10	8.60	6.90	8.60	157.71	Nil	Nil
MS 3	14.00	78.42	8.80	10.50	10.40	8.50	6.90	10.40	161.40	Nil	Nil
MS 4	12.50	17.10	2.50	4.30	4.85	5.10	3.10	5.10	36.48	Nil	Nil
MS 5	17.50	14.40	2.90	4.80	4.10	3.70	2.40	4.80	31.56	Nil	Nil
MS 6	11.00	74.20	7.30	9.10	8.87	6.70	4.90	9.10	124.78	Nil	Nil
MS 7	10.85	14.40	2.20	4.20	5.50	5.30	3.40	5.50	36.72	Nil	Nil
MS 8	9.80	25.20	3.80	4.80	4.90	5.00	3.70	5.00	45.15	Nil	Nil
MS 9	8.80	12.50	3.00	4.00	4.60	3.50	1.90	4.60	29.30	Nil	Nil
MS 10	8.00	113.05	12.10	14.50	13.30	9.60	7.50	14.50	259.45	Nil	Nil
MS 11	5.50	22.44	2.80	4.00	5.30	4.20	2.10	5.30	36.16	Nil	Nil
MS 12	5.00	87.47	7.10	8.70	10.40	8.50	6.40	10.40	153.60	Nil	Nil
MS 13	4.00	14.40	2.00	5.00	4.80	4.00	2.70	5.00	33.24	Nil	Nil
MS 14	2.00	80.97	6.50	7.50	7.90	7.60	5.80	7.90	128.99	Nil	Nil
MS 15	0.00	97.90	10.80	14.70	16.04	13.80	10.50	16.04	262.85	Nil	Nil

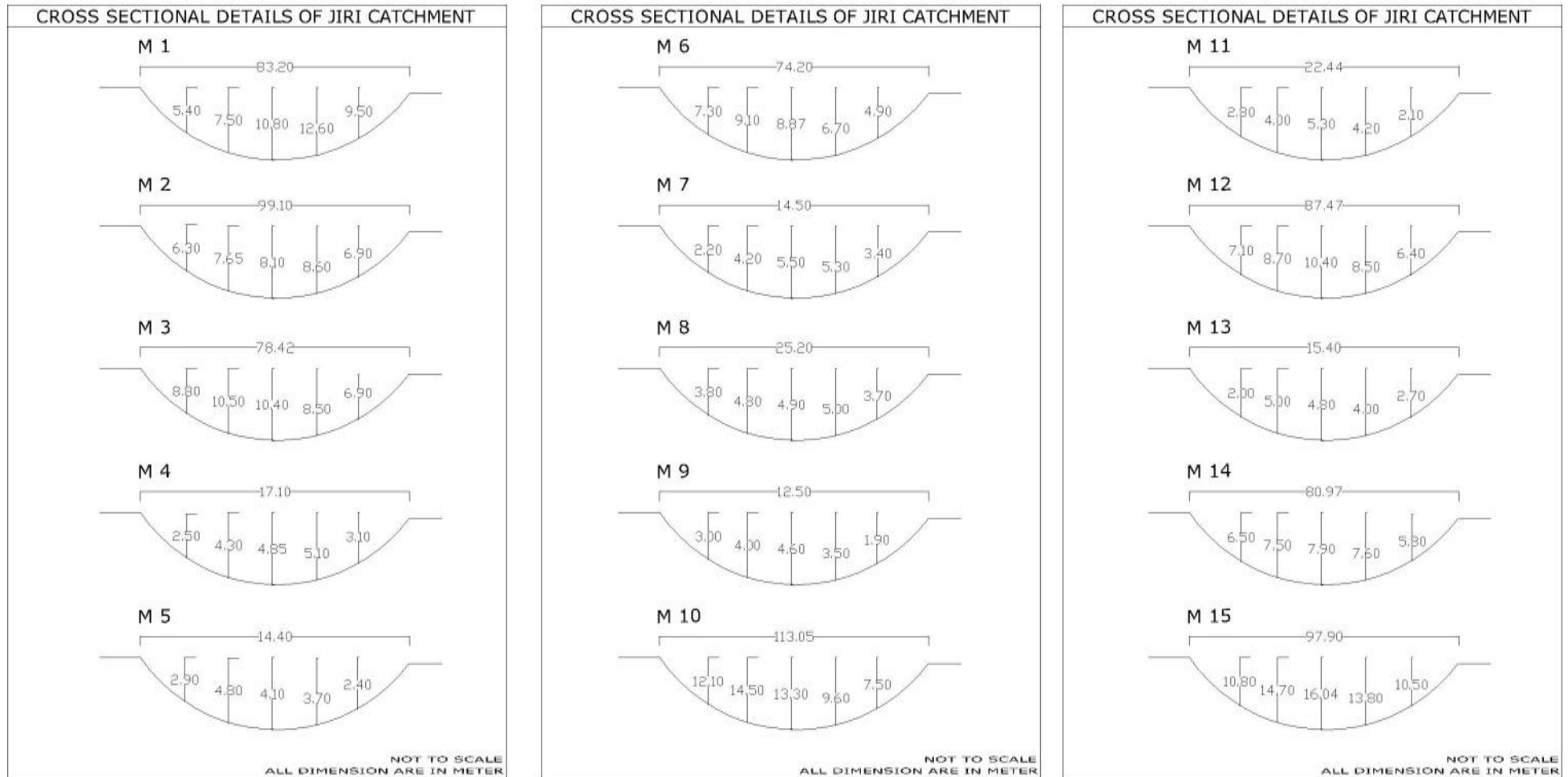

FIGURE 2.4 Section Details of Jiri River system

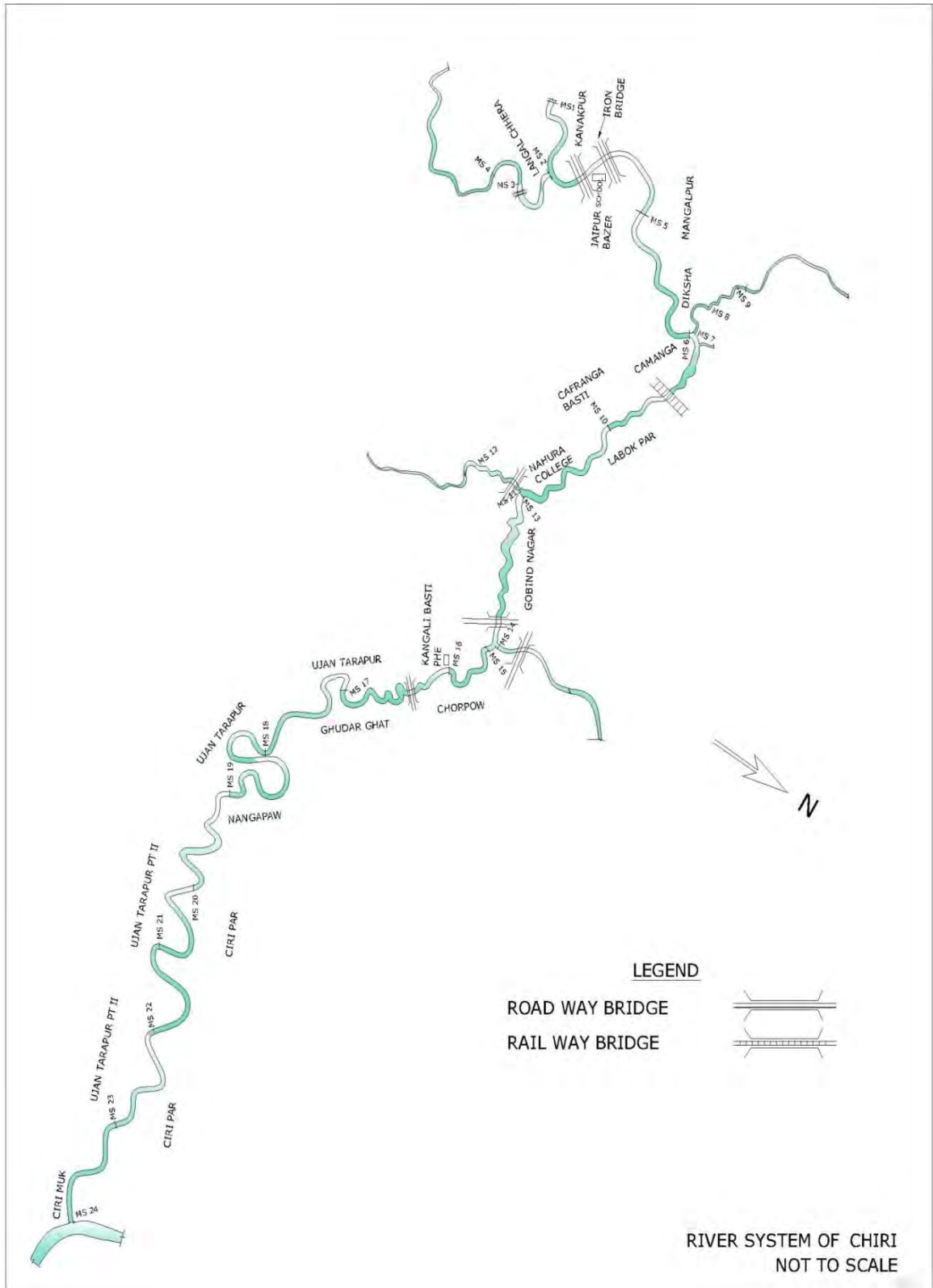

FIGURE 2.5 Name of the sub watershed:- Ciri, Approximate catchment Area : 438.66 km²

Flood Damage Mitigation: Report

TABLE 2.3 Flow area Details of Ciri River system

Maximum Top width = 109.50m

Average Top width = 60.72 m

Name of station	Distance from confluence point with barak in KM(Approx)	Maximum top width (T) in (M)	Vertical depth (m)					Maximum depth (m)	flow area (Approx) in Sq.m	Embankment Details	
			1/6.T	2/6.T	3/6.T	4/6.T	5/6.T			R Bank	L Bank
MS 1	38.00	67.50	6.10	7.00	6.60	4.20	2.90	7.00	86.23	Nil	Nil
MS 2	37.00	29.70	2.50	3.60	6.30	7.30	6.80	7.30	57.42	Nil	Nil
MS 3	37.50	24.10	2.80	3.90	5.30	5.30	4.20	5.30	43.06	Nil	Nil
MS 4	38.00	27.40	3.60	4.80	6.20	6.00	4.20	6.20	51.81	Nil	Nil
MS 5	35.00	64.20	3.60	5.30	6.25	6.50	3.90	6.50	76.23	Nil	Nil
MS 6	32.00	53.70	5.40	6.50	7.40	4.30	3.90	7.40	78.02	Nil	Nil
MS 7	32.00	34.50	3.80	4.90	5.50	6.90	5.90	6.90	62.49	Nil	Nil
MS 8	33.00	31.40	3.10	4.30	5.10	5.50	3.60	5.50	47.33	Nil	Nil
MS 9	34.00	35.50	4.50	5.80	6.70	4.90	3.80	6.70	59.35	Nil	Nil
MS 10	29.00	70.00	3.70	5.10	6.00	6.20	4.50	6.20	82.43	Nil	Nil
MS 11	26.00	32.10	4.50	5.10	7.70	6.00	5.10	7.70	63.28	Nil	Nil
MS 12	27.00	29.50	4.70	4.90	6.60	5.30	4.20	6.60	55.48	Nil	Nil
MS 13	26.00	75.10	6.50	7.50	6.20	7.60	5.80	7.60	119.58	Nil	Nil
MS 14	23.50	26.50	3.20	4.20	5.70	3.40	2.70	5.70	39.63	Nil	Nil
MS 15	23.00	78.00	3.20	5.40	6.10	5.70	3.40	6.10	77.30	Nil	Nil
MS 16	20.00	85.50	4.60	5.70	6.80	3.90	3.40	6.80	89.80	Nil	Nil
MS 17	17.00	70.50	6.30	8.50	7.10	5.20	4.10	8.50	102.70	Nil	Nil
MS 18	14.00	63.50	5.30	6.60	5.40	4.20	3.10	6.60	76.85	Nil	Nil
MS 19	11.00	91.50	4.20	5.80	6.60	4.70	3.50	6.60	92.91	Nil	Nil
MS 20	8.00	95.50	3.20	4.50	5.80	6.20	4.60	6.20	95.08	Nil	Nil
MS 21	6.00	109.50	4.50	6.90	4.80	2.60	1.70	6.90	85.18	Nil	Nil
MS 22	4.00	91.20	3.90	5.10	6.30	5.30	4.20	6.30	94.96	Nil	Nil
MS 23	2.00	88.50	2.10	6.20	6.90	5.40	3.00	6.90	74.61	Nil	Nil
MS 24	0.00	82.30	7.50	8.70	11.20	8.90	8.10	11.20	164.59	Nil	Nil

Flood Damage Mitigation: Report

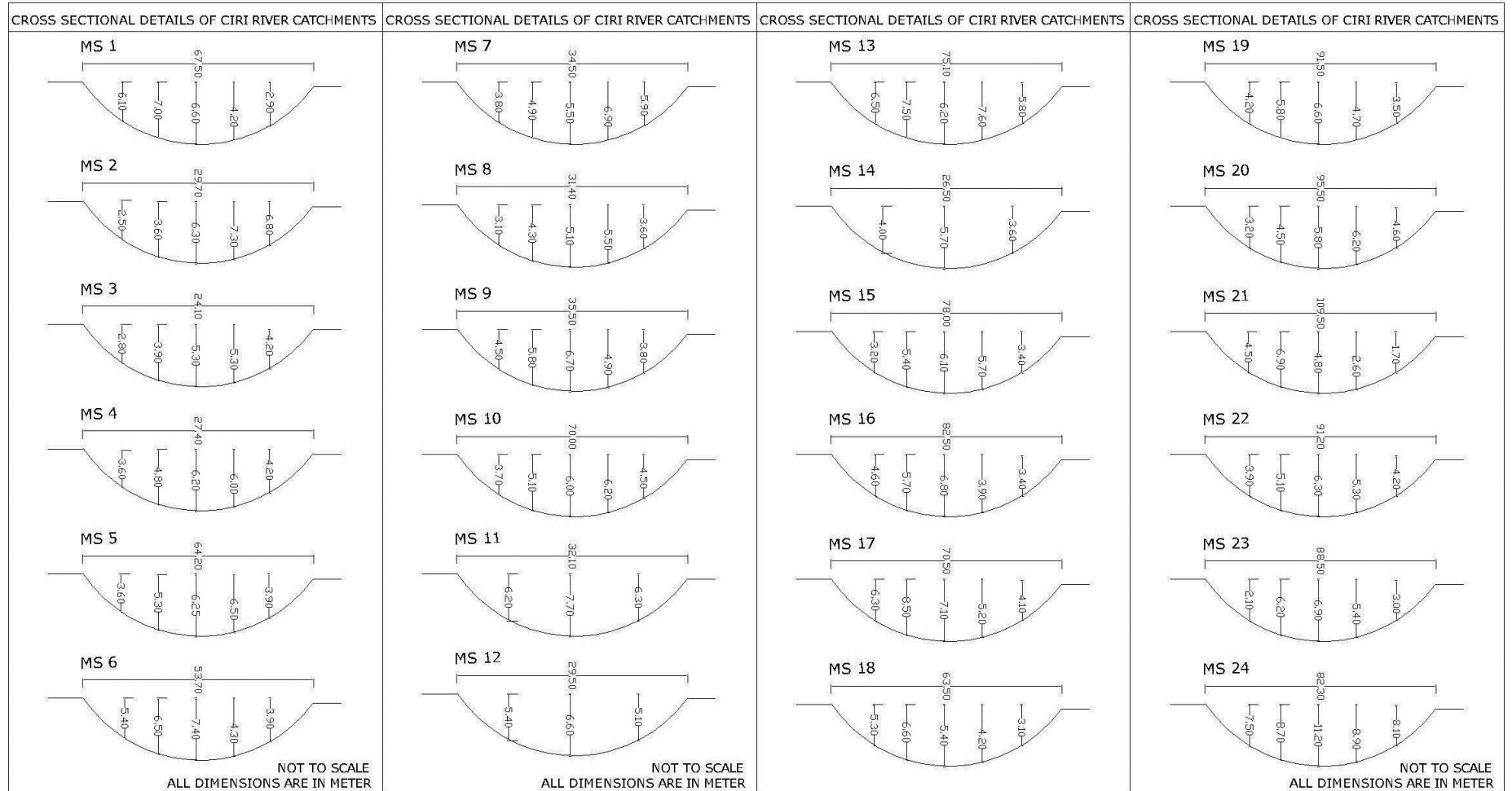

FIGURE 2.6 Section Details of Ciri River system

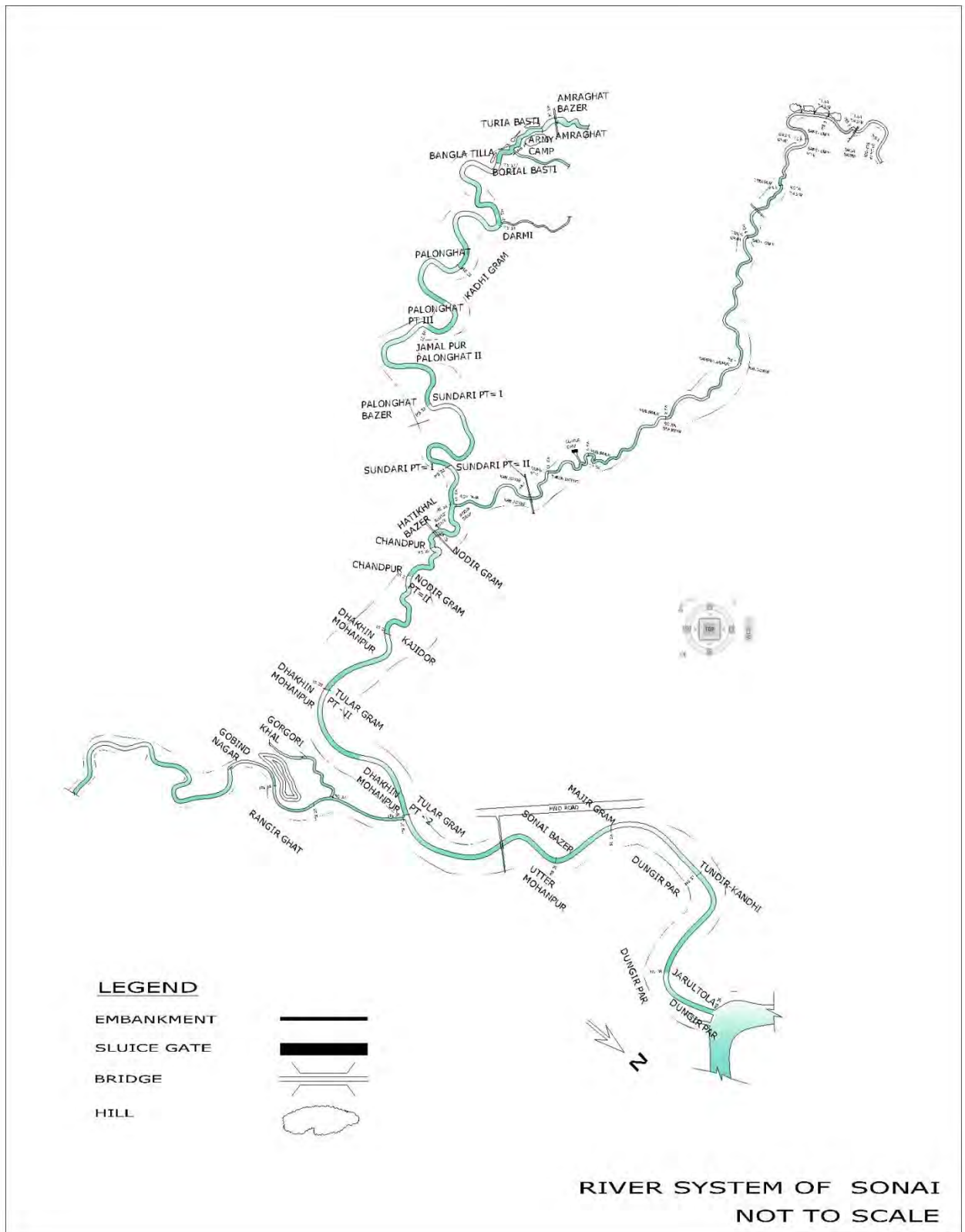

FIGURE 2.7 Name of the sub watershed:- Sonai, Approximate catchment Area : 488.249 km²

Flood Damage Mitigation: Report

TABLE 2.4 Flow area Details of Sonai River system

Maximum top width = 163.20 m

Average top width = 80.22 m

Name of station	Distance from confluence point with barak in kM(Approx)	Maximum top width (T) in(M)	Vertical depth (m)					Maximum depth(m)	flow area (Approx) in Sq.M	Embankment Details	
			1/6.T	2/6.T	3/6.T	4/6.T	5/6.T			R Bank	L bank
MS 1	52.00 (Right side 2)	92.50	6.20	9.15	12.02	11.25	9.20	12.02	183.55	Nil	D=66.25M H=1.00 M
MS 2	51.00 (Right side 2)	98.40	8.30	8.90	14.35	10.10	9.50	14.35	212.66	Nil	D=166.20 M H=0.30M
MS 3	49.50 (Right side 2)	75.50	5.40	6.50	7.54	5.20	4.40	7.54	100.14	Nil	D=62.75M H = 2.70M
MS 4	46.50 (Right side 2)	60.10	5.00	5.90	6.30	6.50	5.20	6.50	88.49	D=520.05M H=0.90	D=66.55M H=0.70 M
MS 5	43.50 (Right side 2)	59.50	4.10	6.20	9.20	9.50	7.20	9.50	105.83	D=149.75M H=1.00 M	H=232.7M H=2.30 M
MS 6	40.50 (Right side 2)	61.50	5.10	7.60	9.30	4.00	2.00	9.30	78.19	D=64.25M H=1.20 M	D=555.75 H=1.00M
MS 7	37.50 (Right side 2)	52.50	5.00	5.20	7.85	5.20	3.40	7.85	73.25	D=435.75 M H=1.40	D=62.25M H=2.50 M
MS 8	34.50 (Right side 2)	68.70	7.20	8.70	6.30	3.50	2.20	8.70	90.82	D=72.35 M H=1.50M	D=132.3M H=1.20 M
MS 9	31.50 (Right side 2)	60.50	5.20	5.30	8.10	5.70	4.30	8.10	86.10	D=111.25 M H=1.50	Nil
MS 10	28.50 (Right side 2)	58.80	4.00	5.20	7.70	6.40	4.90	7.70	82.21	D=83.40M H=0.70	D=179.4M H=1.10 M
MS 11	25.50 (Right side 2)	64.50	6.50	9.20	6.20	5.30	4.30	9.20	99.45	D=119.25 H=3.00 M	D=60.75M H=1.50 M
MS 12	22.50 (Right side 2)	61.50	6.50	9.20	6.20	5.80	4.30	9.20	97.75	Nil	D = 2KM H=2.50
MS 13	37.50 (Left side)	52.40	9.10	11.50	15.10	9.50	7.30	15.10	143.81	D=96.20 M H=0.90M	Nil

Flood Damage Mitigation: Report

TABLE 2.4 Sonai River system-Contd

Name of station	Distance from confluence point with barak in kM(Approx)	Maximum top width (T) in(M)	Vertical depth (m)					Maximum depth(m)	flow area (Approx) in Sq.M	Embankment Details	
			1/6.T	2/6.T	3/6.T	4/6.T	5/6.T			R Bank	L bank
MS 14	36.50 (Left side)	56.60	8.10	9.50	14.55	10.30	8.30	14.55	146.05	D=48.30 M H=0.90M	PWD RD
MS 15	35.50 (Left side)	110.00	6.90	8.80	10.10	10.20	7.50	10.20	190.20	D=139.00M H=1.20 M	PWD RD
MS 16	34.00 (Left side)	22.20	3.50	5.50	6.80	4.70	2.80	6.80	45.66	Nil	Nil
MS 17	33.50 (Left side)	70.20	4.80	6.30	9.60	5.60	4.20	9.60	95.65	D=209.60 M H=0.30 M	PWD RD
MS 18	31.70 (Left side)	25.20	2.80	5.00	6.10	4.80	3.10	6.10	44.19	Nil	Nil
MS 19	31.50 (Left side)	91.20	6.00	7.60	10.20	7.10	4.90	10.20	132.64	D-128.10 M H=2.10 M	D = 129.60M H=0.30
MS 20	29.50 (Left side)	106.20	4.00	5.20	7.70	6.40	4.90	7.70	117.37	D=93.60 M H=1.10	D=323.1M H=1.20 M
MS 21	27.50 (Left side)	82.50	7.30	8.80	10.20	5.80	4.20	10.20	128.66	D-127.25 M H=1.20 M	D = 186.25M H=1.20M
MS 22	25.50 (Left side)	79.50	4.50	6.10	7.40	5.70	4.20	7.40	96.04	D-62.25 M H=2.30 M	D = 129.75M H=1.30 M
MS 23	23.50 (Left side)	89.50	4.50	6.50	7.80	8.50	6.10	8.50	124.66	D-1 km H=1.20 M	Nil
MS 24	22.50 (Left side)	85.50	5.20	6.70	8.20	6.20	4.90	8.20	114.16	D-77.75 M H=1.90 M	D = 2 km H= 2.50 M
MS 25	20.50	103.50	4.80	6.50	8.90	5.90	4.50	8.90	122.81	D-581.75 M H=0.80 M	D = 144.25 M H=1.20M
MS 26	18.50	101.50	4.50	6.00	7.80	5.70	4.10	7.80	111.74	D-83.25 M H= 2.20 M	D = 66.25M H=2.10 M
MS 27	16.50	108.00	5.80	7.10	8.80	6.30	4.30	8.80	135.30	D-774 M H=2.00 M	D = 153.50 M H= 3.00

Flood Damage Mitigation: Report

TABLE 2.4 Flow area Details of Sonai River system-Contd

Name of station	Distance from confluence point with barak in kM(Approx)	Maximum top width (T) in(M)	Vertical depth (m)					Maximum depth(m)	flow area (Approx) in Sq.M	Embankment Details	
			1/6.T	2/6.T	3/6.T	4/6.T	5/6.T			R Bank	L bank
MS 28	14.50	107.10	6.10	7.20	10.10	5.70	4.80	10.10	143.28	Nil	D = 122.50 M H= 3.00
MS 29	12.50	148.50	4.10	6.20	8.30	7.10	5.70	8.30	164.48	D-150.25 M H=2.10 M	D = 103.25 M H= 2.20 m
MS 30	10.50	91.20	4.20	5.90	7.30	6.50	5.20	7.30	110.84	D-48.60M H= 1.20 M	D = 43.10M H=1.50 M
MS 31	10.5 (Right side 1)	54.10	3.70	5.90	9.50	6.40	4.80	9.50	81.92	D-105.55 M H= 0.90 M	katcha Rd
MS 32	11.50 (Right side 1)	45.80	3.10	5.40	6.80	4.90	4.10	6.80	61.68	Nil	Nil
MS 33	12.00 (Right side 1)	50.30	3.90	5.20	7.55	5.70	4.20	7.55	70.85	D-34.55 M H= 2.10 M	Nil
MS 34	12.70 (Right side 1)	51.80	5.10	6.50	7.10	4.80	3.40	7.10	73.49	D = 82.90 M H=2.00 M	Nil
MS 35	8.50	106.50	5.40	6.70	8.10	7.00	5.50	8.10	140.34	D= 209.25 M H= 0.90 M	PWD RD
MS 36	6.50	108.50	6.80	8.50	8.00	6.10	4.80	8.50	150.08	D=86.45M H= 0.90 M	D = 167.25M H= 4.00 M
MS 37	4.50	133.00	10.20	14.60	9.30	5.30	4.10	14.60	216.89	D= 0.00 M H= 0.00M	D = 157.50 M H = 1.50 M
MS 38	2.50	163.20	2.05	3.10	8.00	10.40	7.80	10.40	176.96	D= 269.10 M H= 1.10 M	D = 289.10M H=1.20 M
MS 39	0.00	70.50	7.10	9.20	10.10	5.10	4.50	10.10	116.95	D=222.75 M H= 1.10 M	D = 1 km H=2.00 M

Flood Damage Mitigation: Report

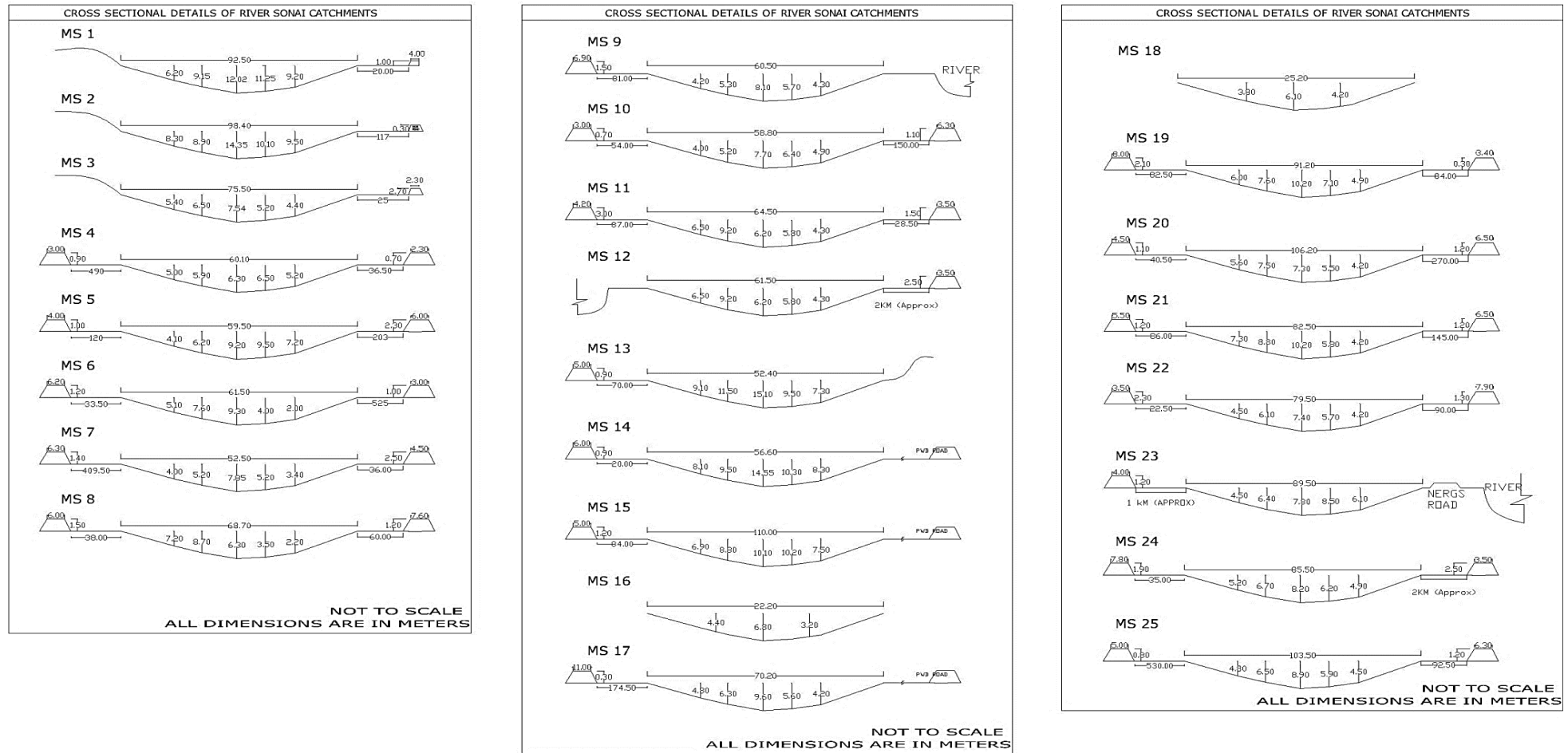

FIGURE 2.8(a) Section Details of Sonai River system

Flood Damage Mitigation: Report

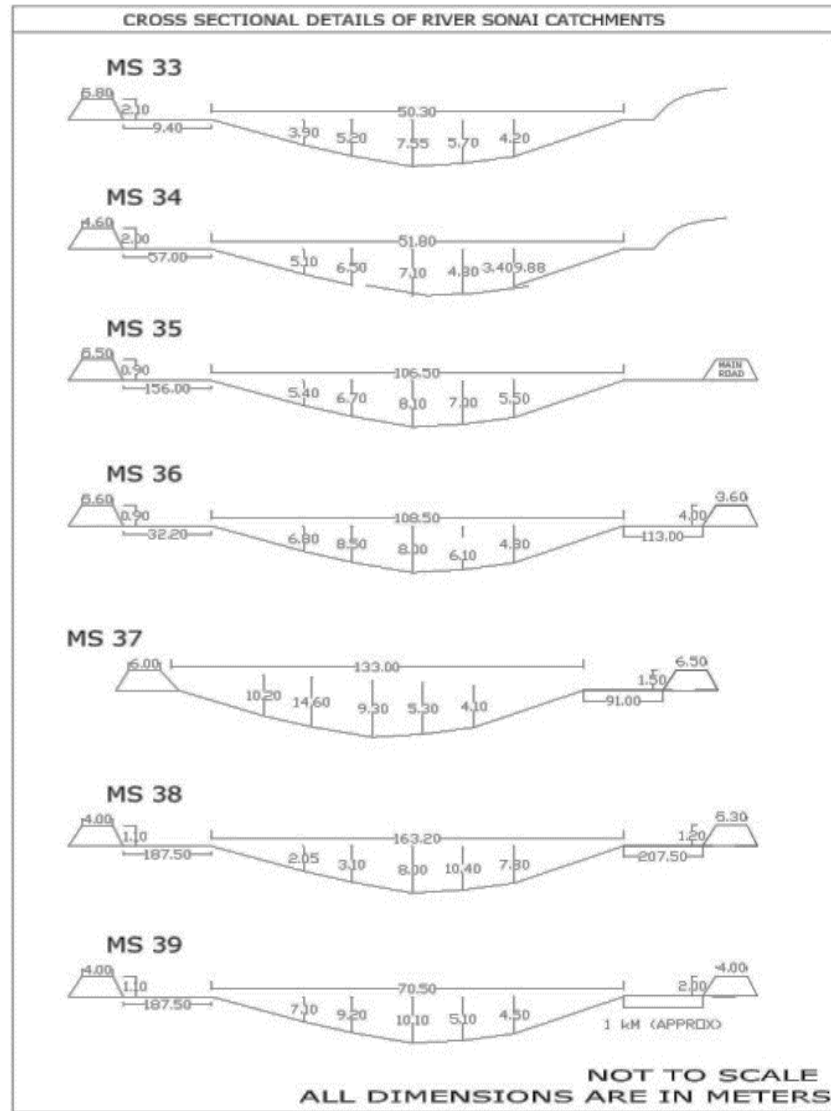
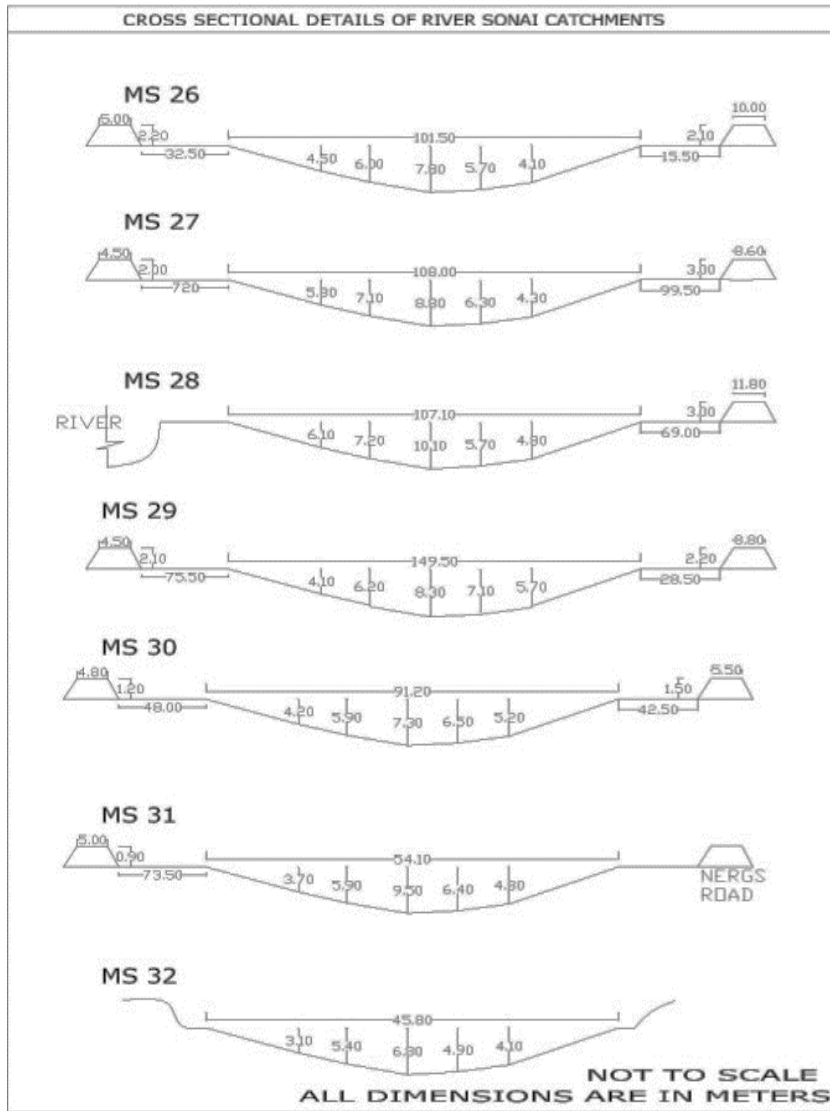

FIGURE 2.8(b) Section Details of Sonai River system-Contd

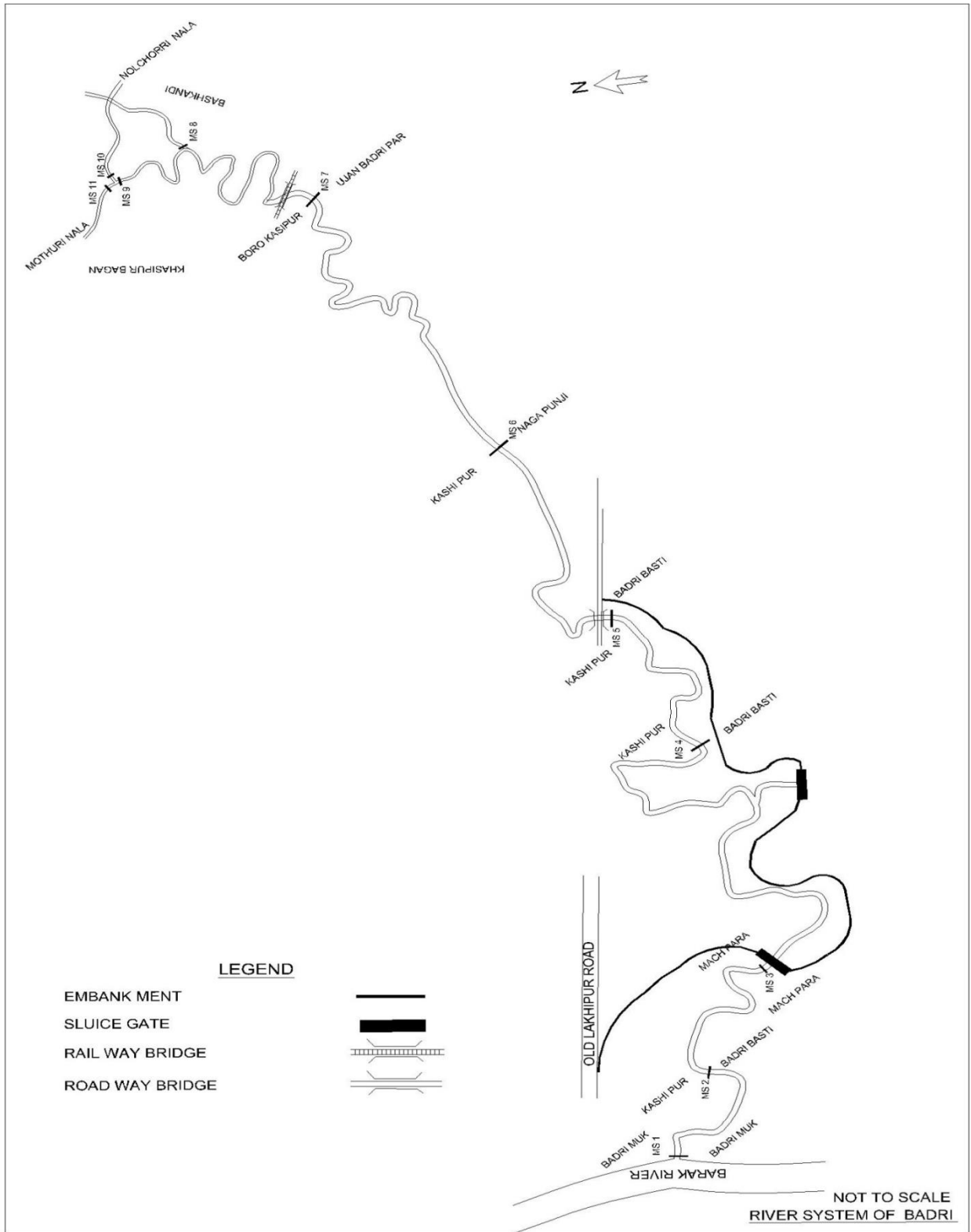

FIGURE 2.9 Name of the sub watershed:- Badri, Approximate catchment Area : 338.66 km²

TABLE 2.5 Flow area Details of Badri River system

Maximum top width = 103.50 M ,Average top width = 50.08 m

Name of station	Distance from confluence point with borak in kM (Approx)	Maximum top width (T) in (M)	Vertical depth (m)					Maximum depth (m)	flow area (Approx) in Sq.m	Embankment Details	
			1/6.T	2/6.T	3/6.T	4/6.T	5/6.T			R Bank	L Bank
MS 1	0.00	46.00	3.70	5.80	8.10	3.70	6.00	8.10	72.38	Nil	Nil
MS 2	1.00	79.60	5.20	6.05	7.70	5.50	4.10	7.70	100.19	Nil	D=390M H=0.45 M
MS 3	2.00	103.50	4.80	11.50	13.40	13.60	7.30	13.60	181.36	Nil	D =72.00 H=4.10
MS 4	6.00	65.10	7.20	11.20	12.10	10.80	6.35	12.10	141.71	D =35.75 H=1.00	Nil
MS 5	7.50	50.20	6.70	8.55	10.50	9.00	5.80	10.50	108.39	D =43.60 H= 1.10	Nil
MS 6	9.00	45.50	4.40	6.02	7.20	5.30	4.00	7.20	68.89	Nil	Nil
MS 7	12.00	40.50	2.90	3.95	5.10	4.50	2.40	5.10	44.99	Nil	Nil
MS 8	16.00	37.10	1.20	2.00	2.92	2.55	1.80	2.92	24.22	Nil	Nil
MS 9	17.00	27.30	2.15	2.90	3.20	2.65	1.93	3.20	26.78	Nil	Nil
MS 10	17.00	24.60	1.96	2.41	3.30	2.60	1.60	3.30	23.92	Nil	Nil
MS 11	17.00	31.50	1.75	3.10	3.60	2.42	2.07	3.60	28.27	Nil	Nil

Flood Damage Mitigation: Report

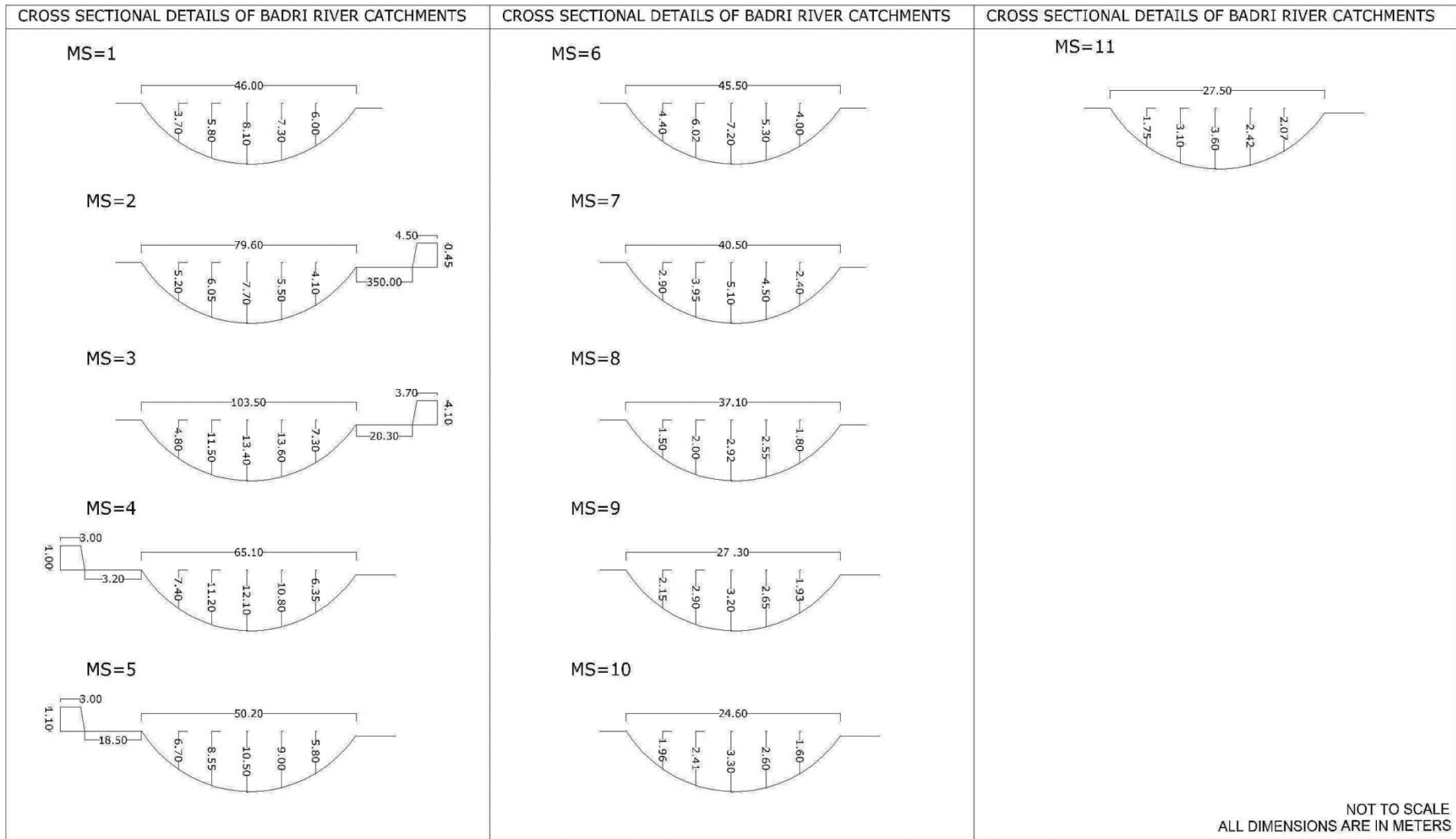

FIGURE 2.10 Section Details of Badri River system

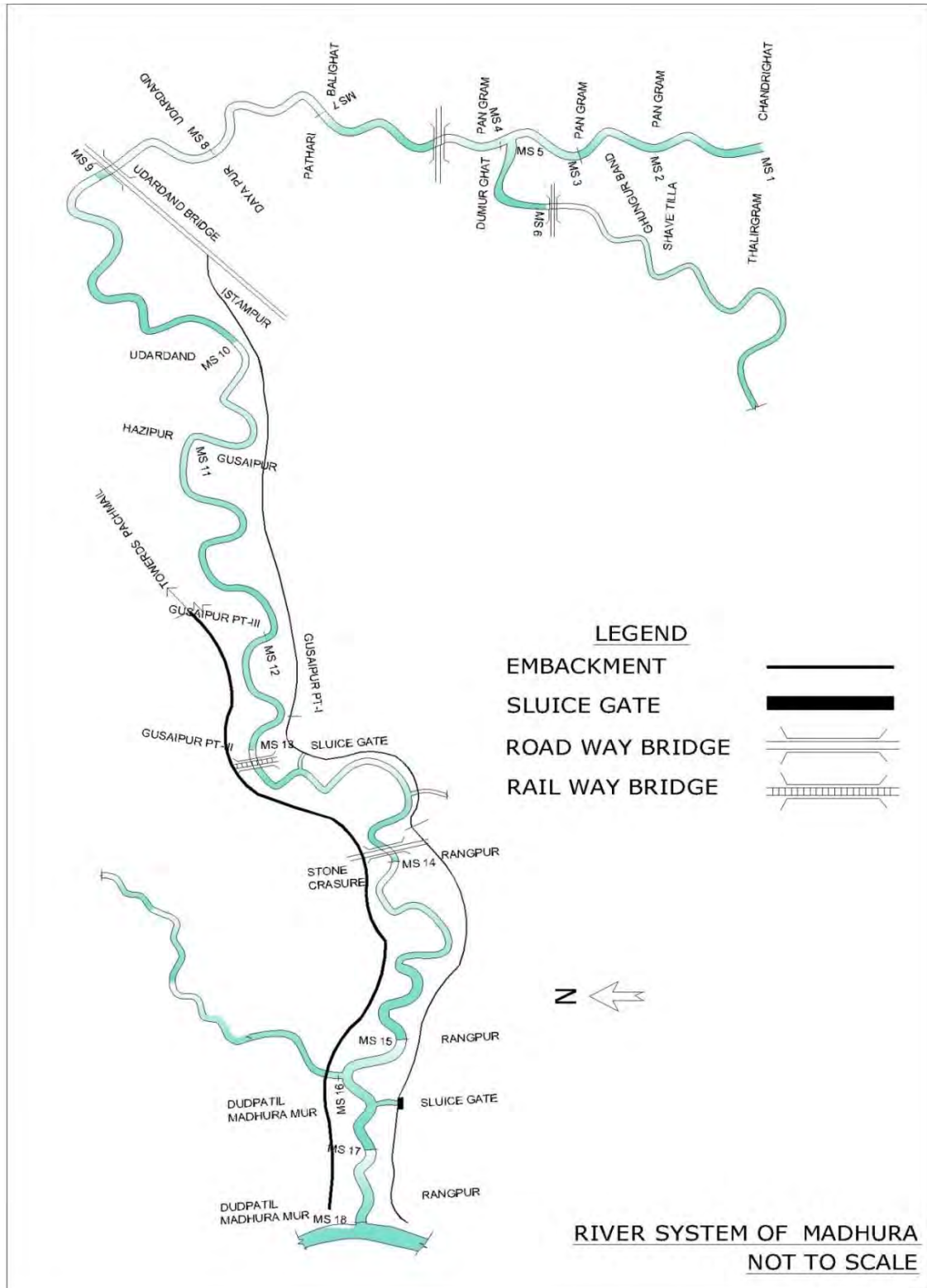

FIGURE 2.11 Name of the sub watershed:- Madhura, Approximate catchment Area : 349.43 km²

Flood Damage Mitigation: Report

TABLE 2.6 Flow area Details of Madhura River system

Maximum top width = 88.20 M, Average top width = 64.11 m

Name of station	Distance from confluence point with barak in kM(Approx)	Maximum top width (T) in (M)	Vertical depth (m)					Maximum depth (m)	flow area (Approx) in Sq.m	Embankment details	
			1/6.T	2/6.T	3/6.T	4/6.T	5/6.T			R Bank	L Bank
MS 1	27.00	68.50	4.20	5.20	5.00	5.10	5.50	5.50	85.97	Nil	Nil
MS 2	25.50	73.00	3.50	4.10	5.00	5.40	6.10	6.10	87.40	Nil	Nil
MS 3	24.00	71.00	3.40	4.60	5.10	5.40	6.70	6.70	89.96	Nil	Nil
MS 4	23.00	86.50	2.50	3.60	4.30	4.70	4.50	4.70	75.66	Nil	Nil
MS 5	23.00	36.10	4.10	5.30	6.10	6.20	6.30	6.30	66.49	Nil	Nil
MS 6	24.00	33.50	5.40	5.60	5.60	4.90	4.40	5.60	59.56	Nil	Nil
MS 7	21.00	78.50	5.70	6.00	6.20	6.30	6.50	6.50	116.81	Nil	Nil
MS 8	19.00	75.50	2.55	3.20	3.85	4.00	4.30	4.30	65.20	Nil	Nil
MS 9	17.00	66.40	4.00	4.90	6.30	6.50	4.90	6.50	84.65	Nil	Nil
MS 10	15.00	43.30	5.00	8.20	9.20	6.40	5.50	9.20	85.49	Nil	Nil
MS 11	14.00	67.00	6.40	6.70	7.15	5.50	4.30	7.15	98.44	Nil	D = 83.00 M H = 1.50 M
MS 12	12.00	68.50	5.10	5.30	6.65	5.20	4.90	6.65	91.38	Nil	D = 42.00 M H = 2.00 M
MS 13	10.00	70.00	6.90	7.90	8.55	5.70	4.70	7.90	111.97	Nil	D = 134.00 M H = 1.80 M
MS 14	8.00	67.40	6.75	7.50	8.60	7.00	6.30	8.60	119.50	D = 68.70 M H = 1.80 M	D = 107.20 M H = 1.60 M
MS 15	5.00	88.20	6.20	8.50	11.30	9.50	7.30	11.30	157.83	PWD RD	D = 84.60 M H = 2.80 M
MS 16	4.00	30.50	3.30	5.30	7.00	7.70	6.10	7.70	63.89	Nil	Nil
MS 17	2.00	70.50	5.80	8.40	10.20	8.10	5.30	10.20	118.61	D = 51.05 M H = 1.80 M	D = 11.75 M H = 3.30 M
MS 18	0.00	59.50	6.40	7.10	8.55	6.70	5.20	8.55	102.22	D = 180.75M H = 2.00 M	D = 233.250 M H = 5.70 M

Flood Damage Mitigation: Report

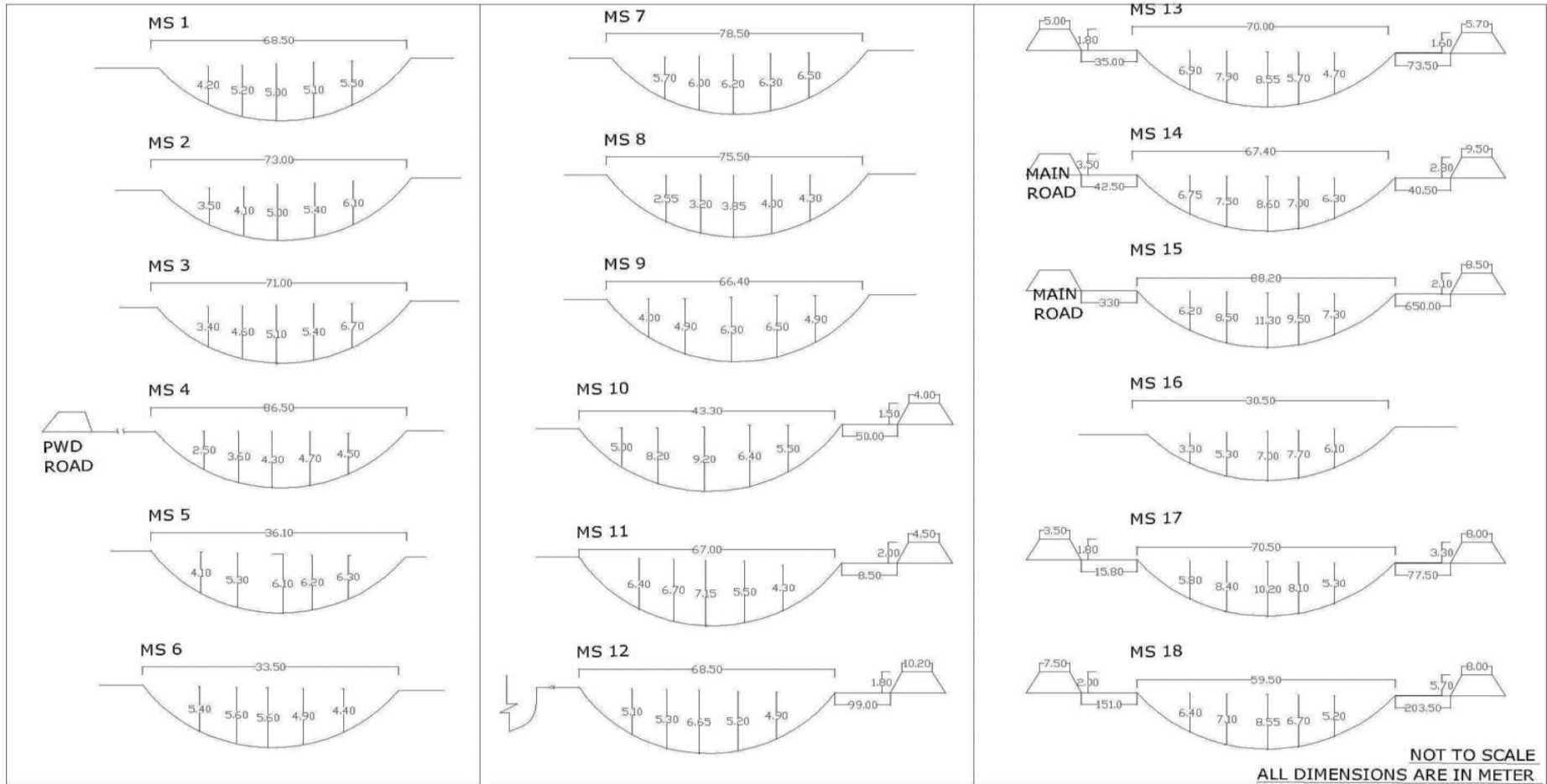

FIGURE 2.12 Section Details of Madhura River system

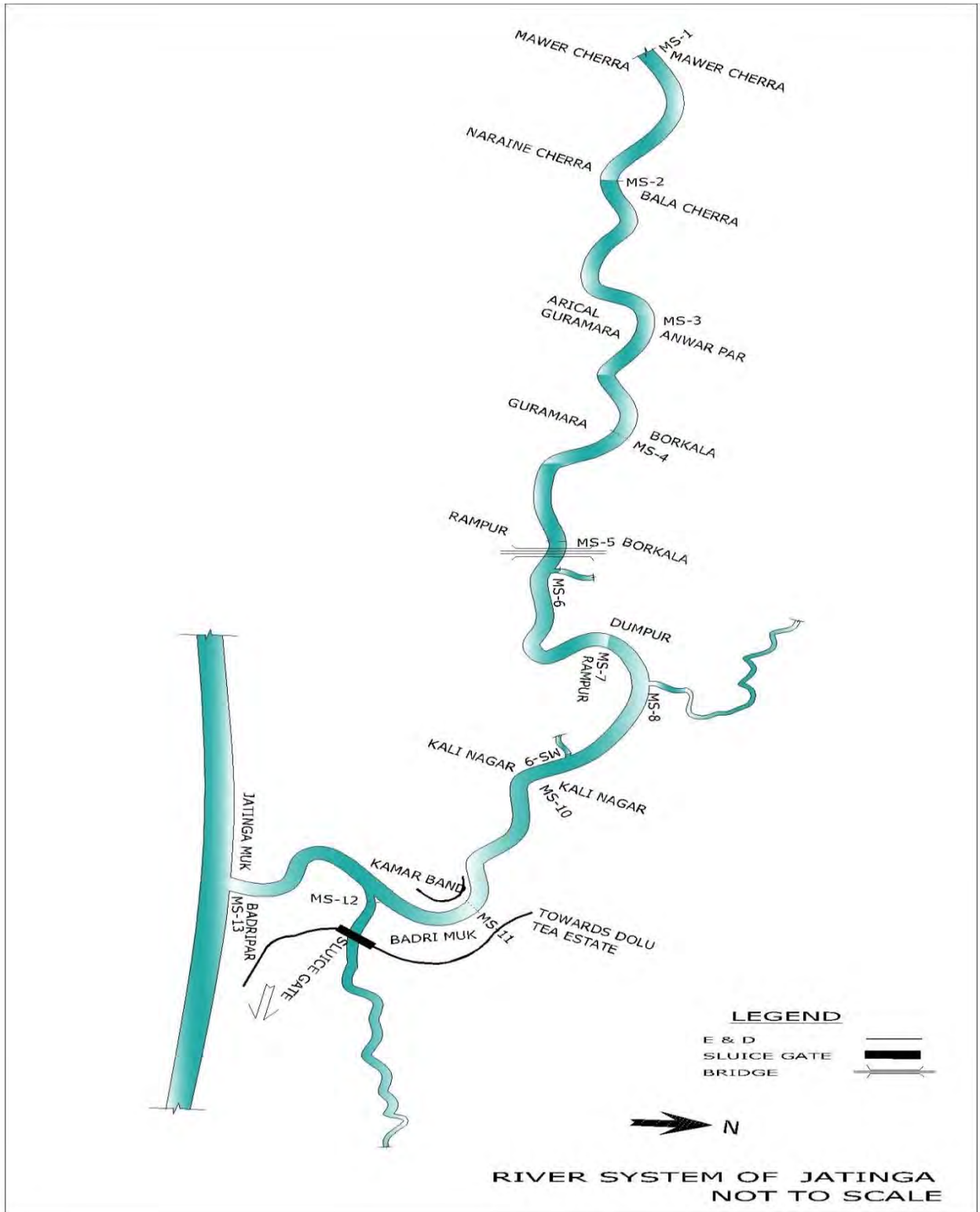

FIGURE 2.13 Name of the sub watershed:-Jatinga, Approximate catchment Area : 371.86 km²

Flood Damage Mitigation: Report

TABLE 2.7 Flow area Details of Jatinga River system

Maximum top width = 98.40 m, Average top width = 66.65 m

Name of station	Distance from confluence point with barak in kM(Approx)	Maximum top width (T) in(M)	Vertical depth (m)					maximum depth (m)	flow area (Approx) in Sq.M	Embankment details	
			1/6.T	2/6.T	3/6.T	4/6.T	5/6.T			R Bank	L bank
MS 1	16.00	92.50	6.20	9.15	12.02	11.25	9.20	12.02	183.55	Nil	Nil
MS 2	14.00	98.40	8.30	8.90	14.35	10.10	9.50	14.35	212.66	Nil	Nil
MS 3	12.00	75.50	5.40	6.50	7.54	5.20	4.40	7.54	100.14	Nil	Nil
MS 4	10.00	60.10	5.00	5.90	6.30	6.50	5.20	6.50	88.49	Nil	Nil
MS 5	8.00	59.50	4.10	6.20	9.20	9.50	7.20	9.50	105.83	Nil	Nil
MS 6	7.50	61.50	5.10	7.60	9.30	4.00	2.00	9.30	78.19	Nil	Nil
MS 7	6.00	52.50	5.00	5.20	7.85	5.20	3.40	7.85	73.25	Nil	Nil
MS 8	5.40	68.70	7.20	8.70	6.30	3.50	2.20	8.70	90.82	Nil	Nil
MS 9	4.50	60.50	5.20	5.30	8.10	5.70	4.30	8.10	86.10	Nil	Nil
MS 10	4.00	58.80	4.00	5.20	7.70	6.40	4.90	7.70	82.21	Nil	Nil
MS 11	2.00	64.50	6.50	9.20	6.20	5.30	4.30	9.20	99.45	Nil	Nil
MS 12	1.00	61.50	6.50	9.20	6.20	5.80	4.30	9.20	97.75	D=105.5M H= 1.60 M	D=168 M H= 1.8M
MS 13	0.00	52.40	9.10	11.50	15.10	9.50	7.30	15.10	143.81	Nil	D=165M H= 1.8M

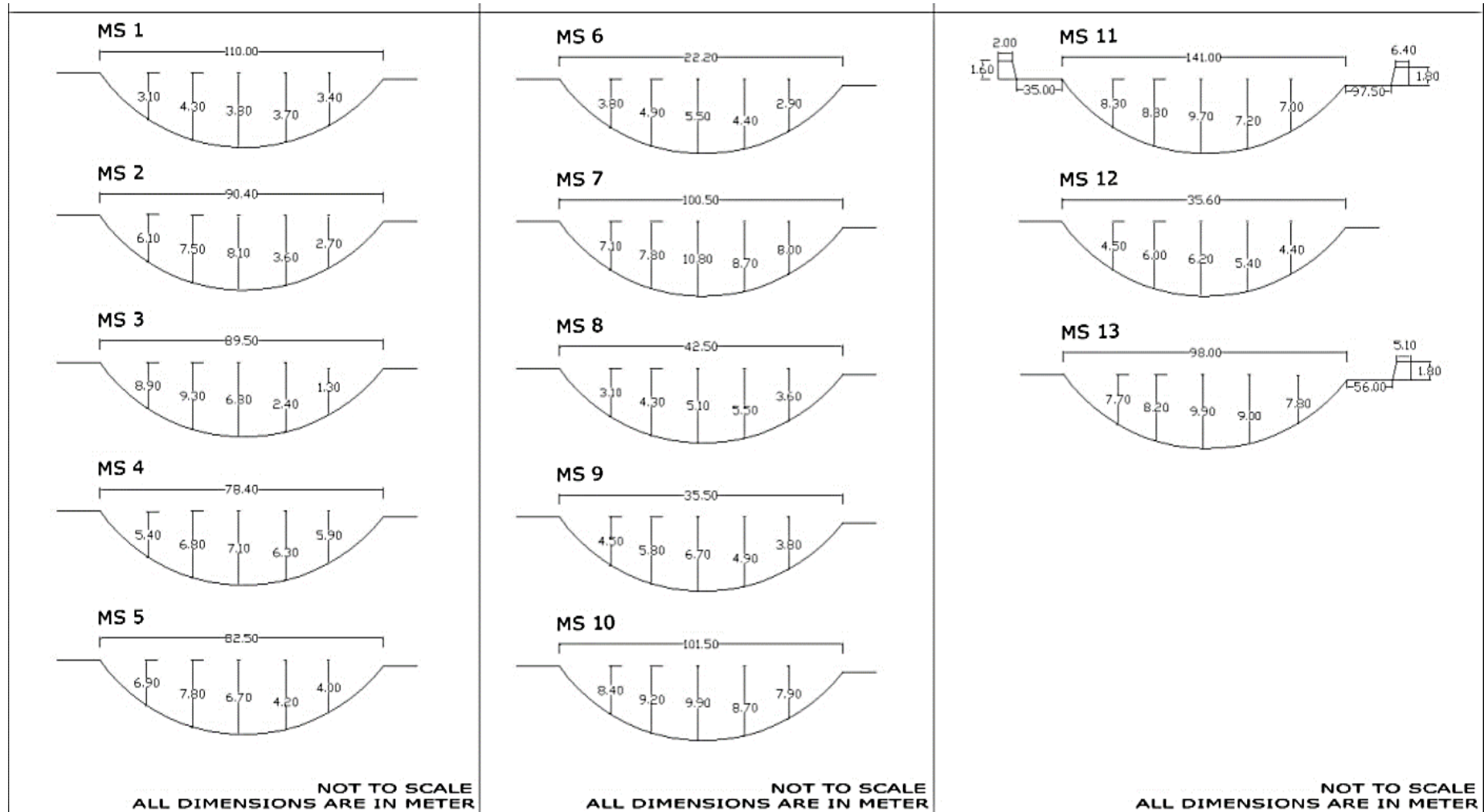

FIGURE 2.14 Section Details of Jatinga River system

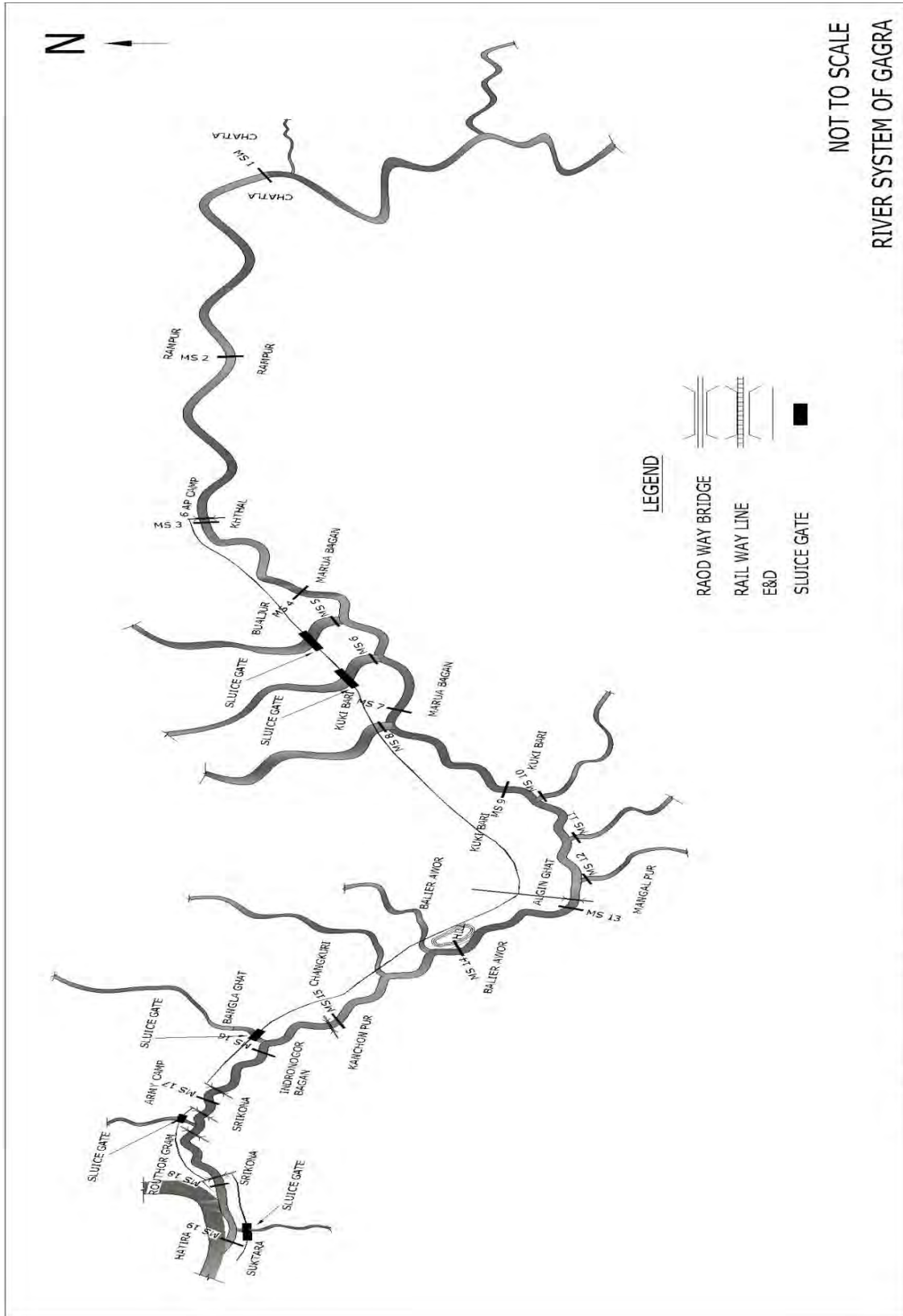

Fig 2.15 : Name of the sub watershed:- Gagra, Approximate catchment Area : 409.39 km²

TABLE 2.8 Flow area Details of Gagra River system

Maximum top width = 71.00 m,

Average top width = 49.95 m

Name of station	Distance from confluence point with barak in kM(Approx)	Maximum top width (T) in (M)	Vertical depth (m)					Maximum depth (m)	flow area (Approx) in Sq.m	Embankment Details	
			1/6.T	2/6.T	3/6.T	4/6.T	5/6.T			R bank	L Bank
MS 1	22.00	62.50	3.90	4.50	5.20	2.70	2.20	5.20	56.57	Nil	Nil
MS 2	21.00	65.50	4.20	5.10	5.55	4.10	3.00	5.55	68.80	Nil	Nil
MS 3	19.50	68.20	4.80	6.90	9.50	6.50	5.20	9.50	102.63	D= 49.00 M H= 2.10 M	Nil
MS 4	18.00	55.20	5.20	6.90	7.50	6.20	5.70	7.50	91.34	D= 53.10M H= 2.10 M	Nil
MS 5	17.50	28.20	2.70	3.20	4.70	4.00	3.10	4.70	37.43	Nil	Nil
MS 6	17.00	20.50	3.90	4.50	5.20	2.70	2.20	5.20	35.22	Nil	Nil
MS 7	16.00	48.40	3.80	5.90	6.80	5.70	4.50	6.80	70.28	D= 229.20 M H= 1.90 M	Nil
MS 8	15.50	19.10	2.50	3.80	4.80	3.90	3.20	4.80	34.07		Nil
MS 9	14.00	71.00	4.20	5.70	7.60	4.70	3.40	7.60	80.97	D= 535 M H= 1.70 M	Nil
MS 10	13.50	18.00	3.30	4.40	4.10	3.50	3.00	4.40	33.45	Nil	Nil
MS 11	13.00	15.60	2.70	3.70	4.30	3.70	2.80	4.30	30.55	Nil	Nil
MS 12	12.50	27.50	3.00	3.20	4.00	2.70	2.50	4.00	32.40	Nil	Nil
MS 13	12.00	55.10	4.20	5.90	7.20	4.20	3.70	7.20	70.87	Nil	Nil
MS 14	10.00	56.50	3.70	5.10	8.10	5.80	4.00	8.10	74.25	Nil	Nil

TABLE 2.8 Flow area Details of Gagra River system-Contd

Name of station	Distance from confluence point with barak in kM(Approx)	Maximum top width (T) in (M)	Vertical depth (m)					Maximum depth (m)	flow area (Approx) in Sq.m	Embankment Details	
			1/6.T	2/6.T	3/6.T	4/6.T	5/6.T			R bank	L Bank
MS 15	8.00	71.00	4.10	6.20	7.50	5.70	4.50	7.50	89.68	D= 76.50 M H= 2.10 M	Nil
MS 16	6.00	66.40	4.50	5.90	6.20	5.40	4.90	6.20	87.01	D= 143 .00M H= 1.70 M	Nil
MS 17	4.00	52.40	6.60	7.50	8.20	6.40	5.30	8.20	96.16	Nil	Nil
MS 18	2.00	87.50	4.70	5.80	8.20	7.10	6.10	8.20	120.95	Nil	D= 140 .00M H= 1.50 M
MS 19	0.00	60.70	5.40	7.20	7.50	6.80	5.80	7.50	99.65	Nil	D= 60.50 M H= 1.70 M

Flood Damage Mitigation: Report

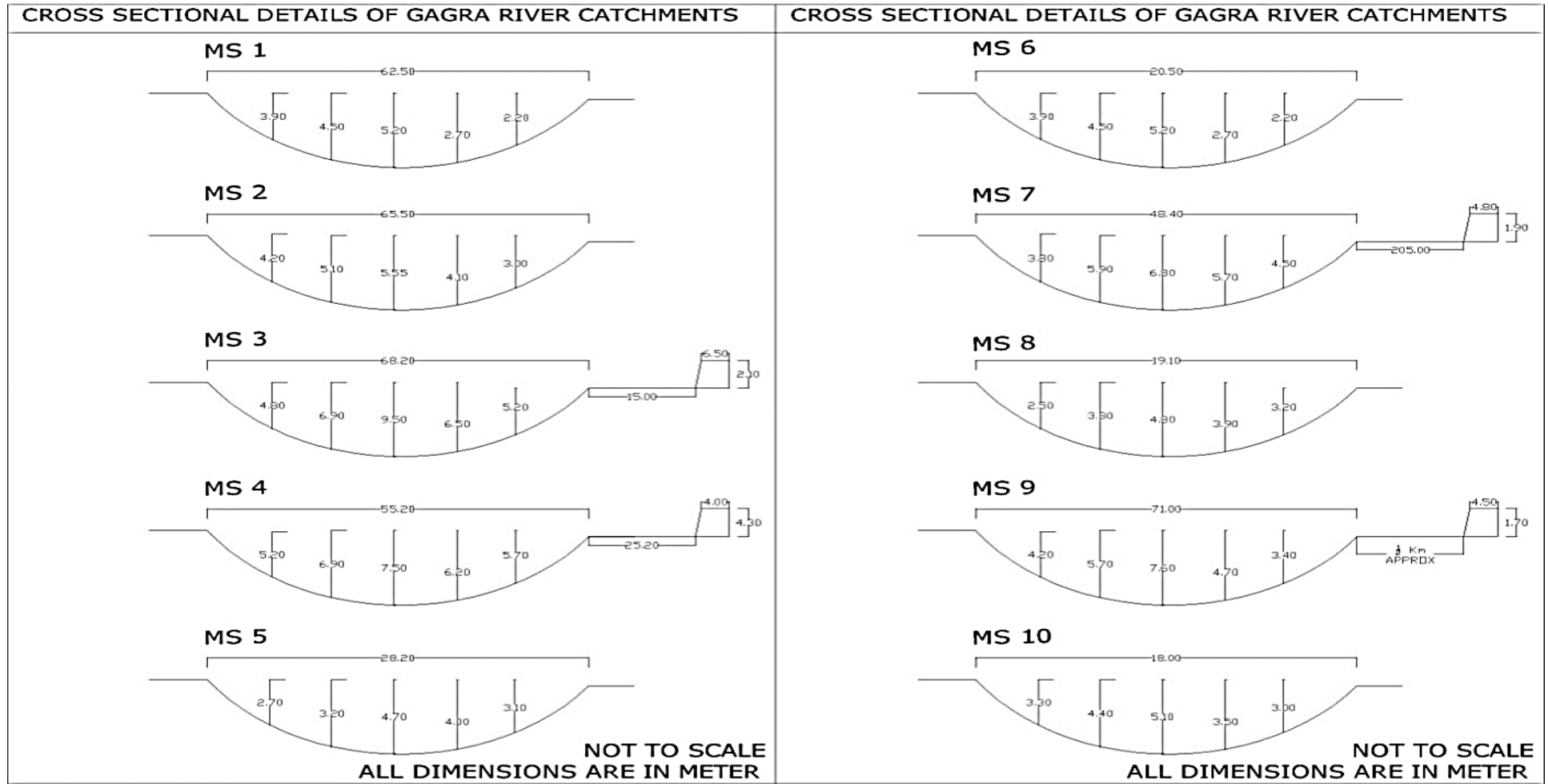

FIGURE 2.16 (a) Section Details of Ghagra River system

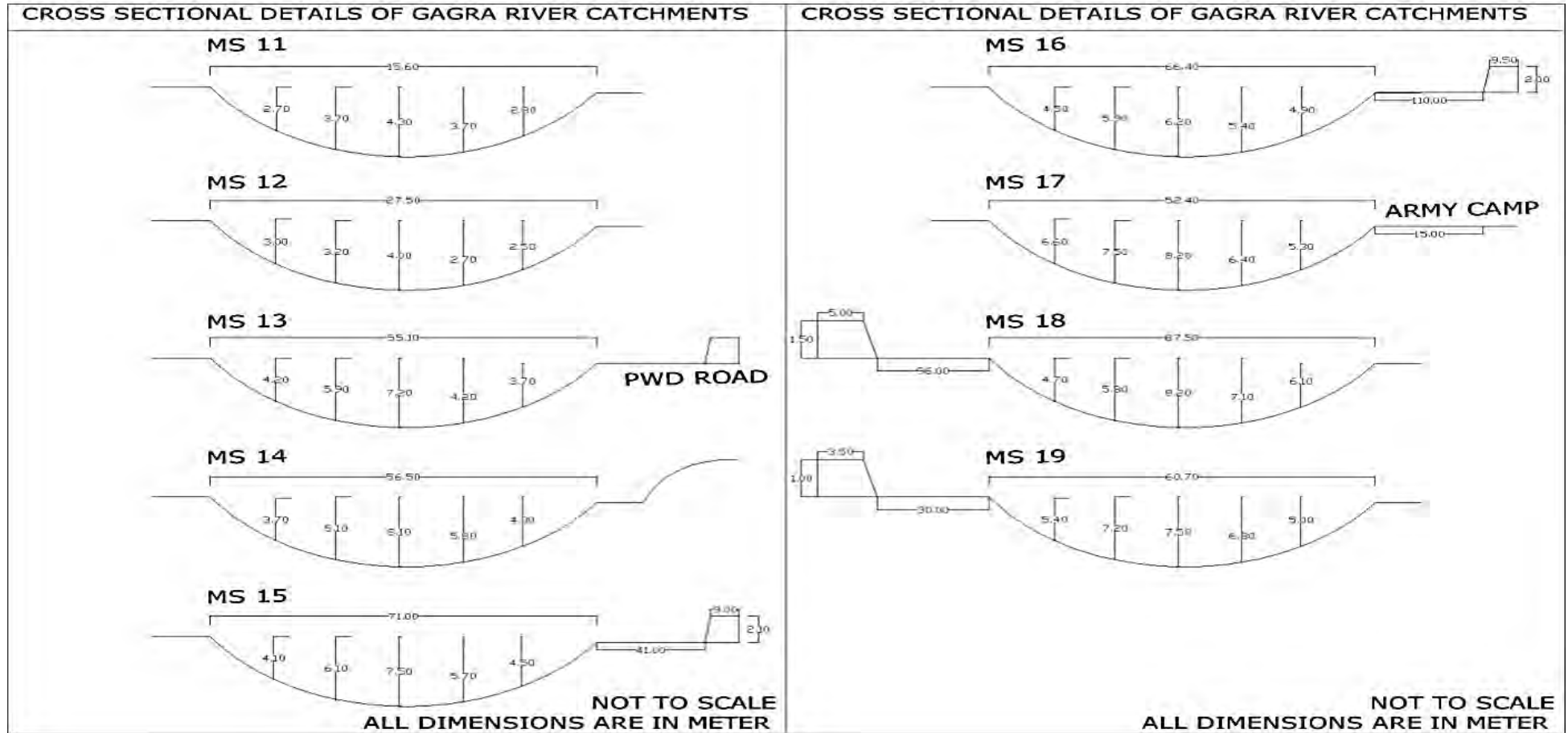

FIGURE 2.16 (b) Section Details of Ghagra River system-contd

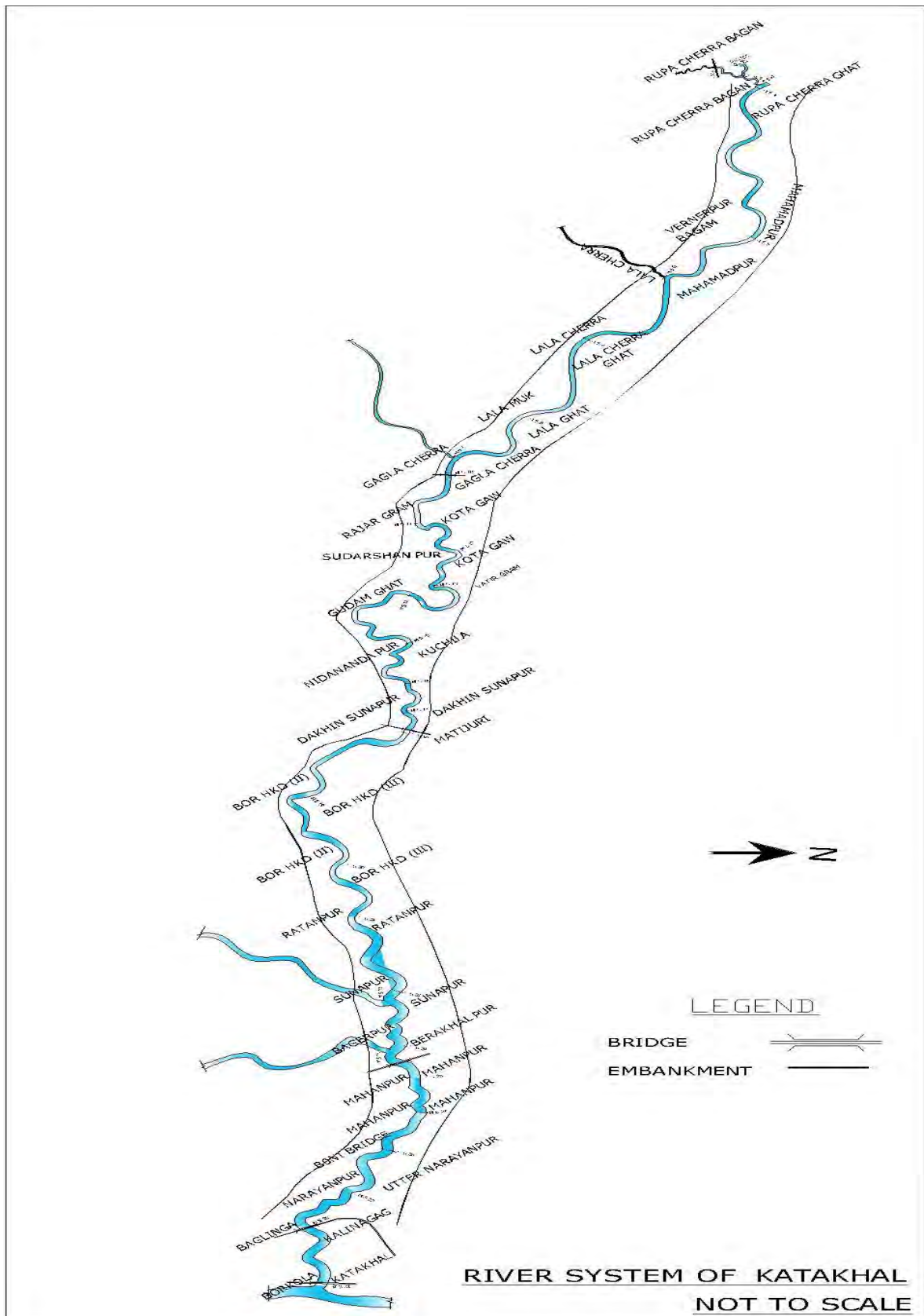

FIGURE 2.17 Name of the sub watershed:- katakhal, approximate catchment Area: 1504.68 km²

TABLE 2.9 Flow area Details of Katakhal River system

Maximum top width = 151.40 m

Average top width = 102.78 m

Name of station	Distance from confluence point with barak in kM(Approx)	Maximum top width (T) in (M)	Vertical depth (m)					Maximum depth (m)	flow area (Approx) in Sq.m	Embankment Details	
			1/6.T	2/6.T	3/6.T	4/6.T	5/6.T			R Bank	L Bank
MS 1	72.00	39.00	6.70	8.00	9.10	7.30	6.00	9.10	90.08	Nil	Nil
MS 2	71.50	34.50	4.00	4.70	7.50	5.90	4.60	7.50	60.93	Nil	Nil
MS 3	71.00	40.50	7.40	10.20	11.70	7.80	6.10	11.70	104.96	Nil	Nil
MS 4	71.00	151.40	9.90	12.70	14.60	15.90	12.50	15.90	369.01	D = 425.70m H = 0.45m	D = 113.70m H = 0.30m
MS 5	61.00	139.00	9.10	10.90	13.00	8.90	7.10	13.00	253.25	D = 134.50m H = 1.20m	D = 123.50m H = 2.00 m
MS 6	63.50	37.80	5.10	6.50	8.70	7.50	5.80	8.70	79.74	Nil	Nil
MS 7	63.00	136.00	7.20	8.50	9.20	8.00	6.50	9.20	206.67	D = 102.50m H = 0.80m	D = 178.00m H = 0.45 m
MS 8	60.00	133.00	8.20	10.50	11.65	15.40	12.10	15.40	300.09	D = 416.50m H = 1.50m	D = 106.5 m H = 1.20 m
MS 9	58.00	42.40	2.70	3.80	6.20	6.80	5.20	6.80	61.51	Nil	Nil
MS 10	57.00	143.50	6.50	8.70	11.10	10.30	8.60	11.10	240.77	D = 134.50m H = 1.10 m	D = 194.00m H = 1.20 m
MS 11	54.00	119.50	9.80	12.10	12.30	9.50	7.90	12.30	244.06	D = 240.00 m H = 1.80 m	D = 125.00 m H = 0.70 m
MS 12	51.00	146.00	8.40	9.30	10.10	8.80	7.60	10.10	251.07	D = 81.00 m H = 1.10 m	D = 221.00 m H = 2.50m

Flood Damage Mitigation: Report

TABLE 2.9 Flow area Details of Katakhal River system-contd

Name of station	Distance from confluence point with barak in kM(Approx)	Maximum top width (T) in (M)	Vertical depth (m)					Maximum depth (m)	flow area (Approx) in Sq.m	Embankment Details	
			1/6.T	2/6.T	3/6.T	4/6.T	5/6.T			R Bank	L Bank
MS 13	48.00	132.50	8.40	10.00	12.70	12.80	10.20	12.80	276.38	D = 132.00m H = 1.20m	D = 93.00 m H = 0.60 m
MS 14	45.00	151.00	5.80	7.10	8.10	6.50	5.00	8.10	179.30	D = 245.00m H = 0.70 m	D = 150.50m H = 1.10 m
MS 15	42.00	107.70	8.80	10.50	11.40	9.80	9.20	11.40	224.95	D = 303.00 m H = 0.50 m	D = 74.00m H = 1.20 m
MS 16	39.00	120.00	7.50	9.10	10.10	8.40	6.90	10.10	199.20	D = 65.00 m H = 0.90 m	D = 66.50 m H = 0.60 m
MS 17	36.00	110.50	7.20	8.60	9.50	9.10	8.20	9.50	196.21	D = 62.00 m H = 0.80 m	D = 68.00m H = 0.70 m
MS 18	33.00	100.50	7.10	8.80	11.20	10.30	8.70	11.20	192.93	D = 50.00 m H = 1.00 m	D = 75.00m H = 0.40 m
MS 19	30.00	125.50	6.50	7.20	11.00	12.40	10.70	14.40	241.08	D = 233.00m H = 1.00 m	D = 131.00m H = 1.00 m
MS 20	27.00	111.00	6.80	8.30	9.90	8.90	7.20	9.90	183.70	D = 90.50m H = 0.90m	D = 67.80 m H = 0.70 m
MS 21	24.00	105.50	8.20	9.10	11.80	9.70	8.70	11.80	209.78	D = 95.00m H = 0.70m	D = 66.00 m H = 0.30 m
MS 22	21.00	112.00	6.20	8.10	9.00	7.50	6.10	9.00	164.00	D = 111.00m H = 0.90m	D = 73.20 m H = 1.00m
MS 23	20.00	41.20	3.80	4.70	5.80	5.00	4.10	5.80	58.12	Nil	Nil

TABLE 2.9 Flow area Details of Katakhal River system-Contd

Name of station	Distance from confluence point with barak in kM(Approx)	Maximum top width (T) in (M)	Vertical depth (m)					Maximum depth (m)	flow area (Approx) in Sq.m	Embankment Details	
			1/6.T	2/6.T	3/6.T	4/6.T	5/6.T			R Bank	L Bank
MS 24	18.00	104.50	8.20	10.10	11.20	8.10	6.90	11.20	190.30	D = 562.00m H = 1.20 m	D = 100.00m H = 0.65 m
MS 25	17.00	30.50	3.10	3.70	4.90	4.00	3.50	4.90	41.98	Nil	Nil
MS 26	15.00	115.50	8.70	10.50	10.30	11.70	9.10	10.50	236.33	D = 71.00m H = 1.00 m	D = 151.0m H = 1.00 m
MS 27	12.00	123.00	9.80	10.70	10.80	11.50	10.40	11.50	273.05	D = 97.5 m H = 1.20 m	D = 191.5m H = 1.00 m
MS 28	9.00	108.00	7.80	9.30	10.60	12.80	11.40	12.80	238.20	Nil	D = 91.50m H = 0.90 m
MS 29	6.00	120.00	8.70	10.40	10.80	8.80	8.10	10.80	228.00	Nil	D = 463.50m H = 1.40m
MS 30	3.00	104.00	8.20	9.70	10.10	8.30	7.30	10.10	190.53	Nil	D = 160.0 m H = 1.80 m
MS 31	0.00	100.70	8.40	9.90	12.40	10.20	8.60	12.40	207.66	Nil	Nil

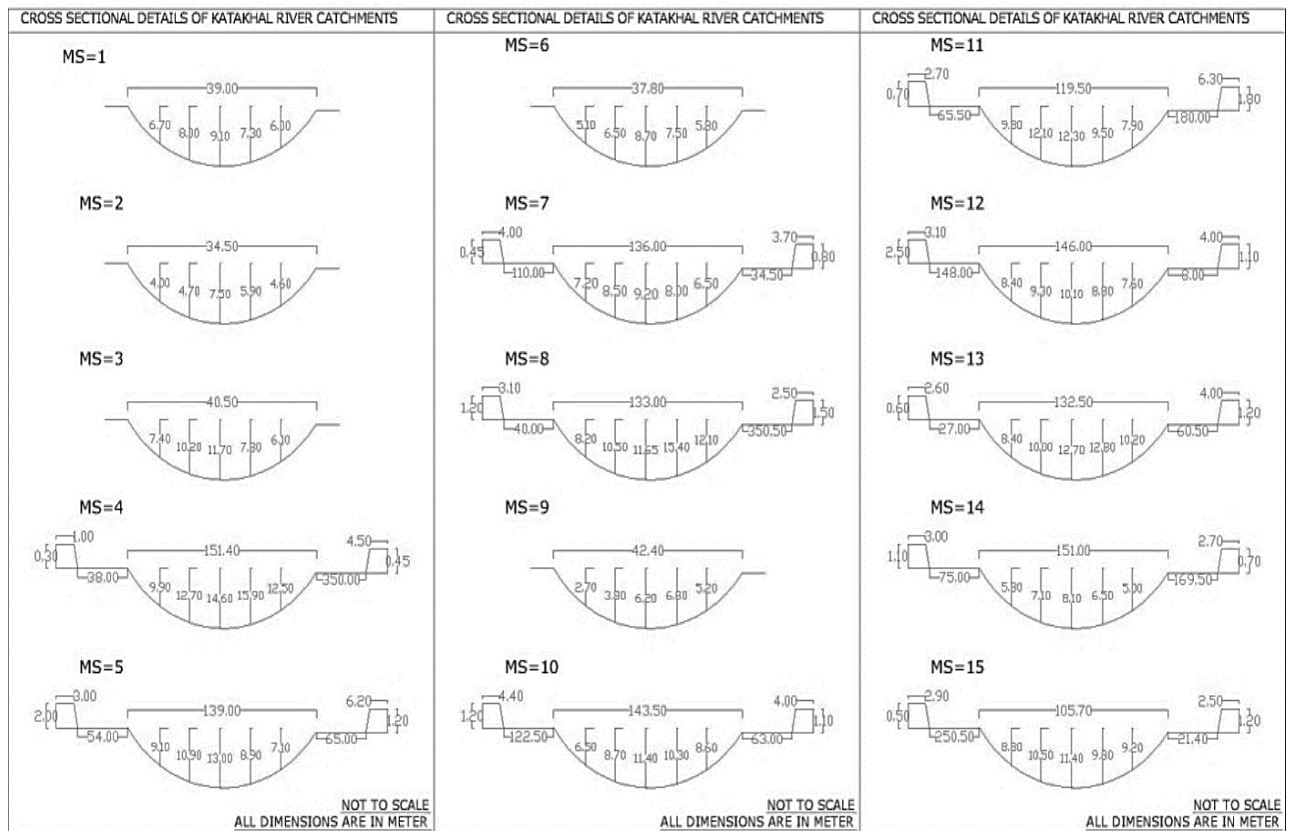
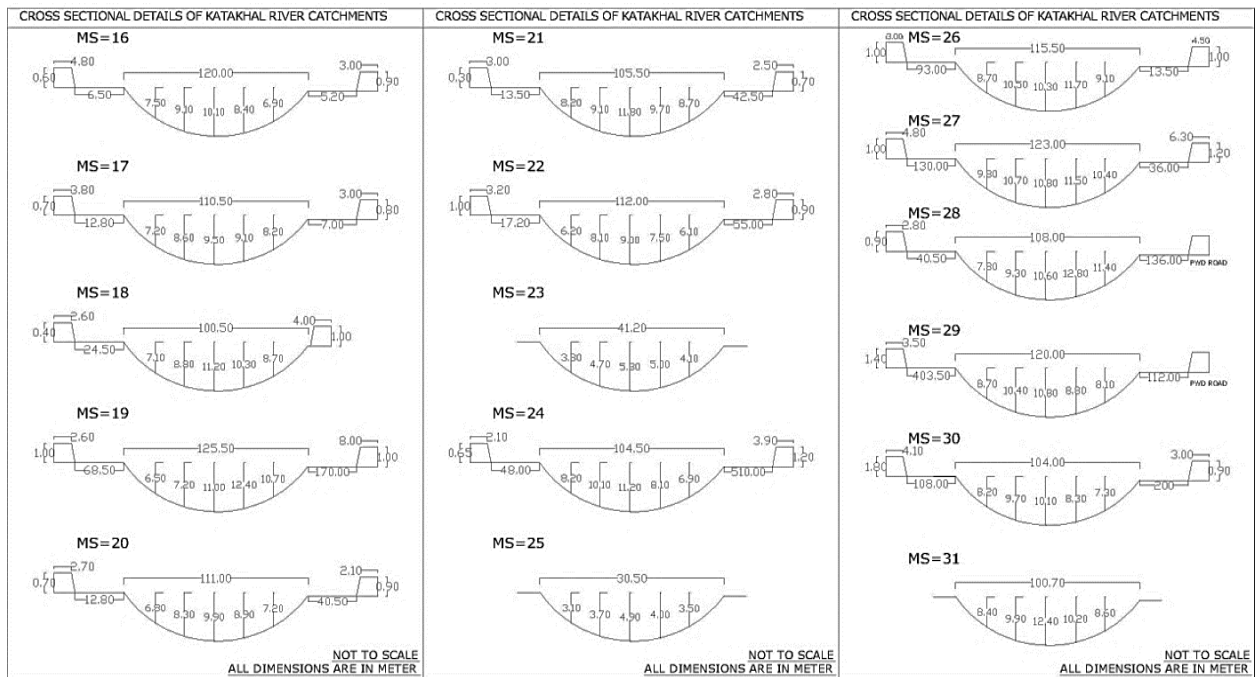

FIGURE 2.18 Section Details of katakhal River system

Flood Damage Mitigation: Report

TABLE 2.10 Flow area Details of Longai River system

Maximum top width = 120.70 m

Average top width = 61.90 m

Name of station	Distance from Bangladesh border(Latu Bridge)	Maximum top width (T) in (M)	Vertical depth (m)					Maximum depth(m)	flow area (Approx) in Sq.m	Embankment Details	
			1/6.T	2/6.T	3/6.T	4/6.T	5/6.T			R Bank	L Bank
MS 1	0.00	120.70	7.70	6.90	5.83	5.20	4.10	7.70	154.55	Nil	Nil
MS 2	2.00	76.80	5.20	6.95	7.20	6.30	5.33	7.20	108.29	Nil	Nil
MS 3	4.00	79.30	6.52	6.40	8.65	6.73	6.00	8.65	126.30	Nil	Nil
MS 4	6.00	75.00	4.00	4.93	7.52	7.40	6.80	7.52	107.20	Nil	Nil
MS 5	8.00	73.50	8.20	8.95	9.32	7.83	7.50	9.32	148.36	Nil	Nil
MS 6	10.00	77.55	6.80	7.92	8.70	5.88	5.30	8.70	123.20	Nil	Nil
MS 7	12.00	70.00	6.50	7.20	7.85	6.35	5.57	7.85	113.21	Nil	Nil
MS 8	14.00	66.40	6.10	6.80	6.84	7.00	6.50	7.00	111.00	Nil	Nil
MS 9	16.00	89.40	5.97	6.72	5.90	4.70	4.05	6.72	109.29	Nil	Nil
MS 10	18.00	82.00	4.85	5.80	7.03	8.92	7.80	8.92	129.94	Nil	Nil
MS 11	20.00	71.00	7.02	8.10	8.60	5.67	5.00	8.60	115.86	Nil	Nil
MS 12	22.00	69.80	8.10	9.92	9.67	4.95	4.03	9.92	119.64	Nil	Nil
MS 13	24.00	93.20	5.70	6.45	6.50	5.82	4.77	6.50	118.86	Nil	Nil
MS 14	29.00	45.50	2.92	3.80	6.52	4.95	6.94	6.94	67.93	Nil	Nil
MS 15	34.00	38.30	2.85	3.70	5.92	4.00	3.51	5.92	47.54	Nil	Nil
MS 16	39.00	42.80	3.60	4.85	5.83	4.44	3.60	5.83	55.92	Nil	Nil
MS 17	42.00	57.00	3.00	3.95	5.80	5.30	4.80	5.80	67.15	Nil	D = 78.50 M H = 1.20 M
MS 18	45.00	56.30	4.22	5.10	5.60	5.92	3.44	5.92	69.18	Nil	Nil

Flood Damage Mitigation: Report

TABLE 2.10 Flow area Details of Longai River system-Contd

Name of station	Distance from Bangladesh border(Latu Bridge)	Maximum top width (T) in (M)	Vertical depth (m)					Maximum depth(m)	flow area (Approx) in Sq.m	Embankment Details	
			1/6.T	2/6.T	3/6.T	4/6.T	1/6.T			Name of station	R Bank
MS 19	50.00	56.50	3.10	3.55	4.52	5.05	5.80	5.80	68.14	D= 58.25 M H = 1.30 M	D = 48.25 M H = 1.20 M
MS 20	55.00	33.50	4.44	6.00	5.02	5.25	4.40	6.00	57.22	D = 56.75M H = 1.80 M	D = 73.75M H = 1.50 M
MS 21	60.00	37.00	3.30	5.32	6.85	4.88	2.80	6.85	52.91	Nil	D = 70.5.00 H 1.80 M
MS 22	65.00	39.20	4.90	5.20	5.65	3.33	2.50	5.65	52.53	D = 24.60M H = 1.80 M	D = 79.60 M H= 1.00 M
MS 23	70.00	50.40	8.10	9.50	5.55	3.27	2.90	9.50	82.84	D= 66.20 H = 2.00 M	D = 25.40 M H = 1.00
MS 24	75.00	79.72	4.50	4.95	4.90	3.12	2.60	4.95	73.11	D = 241.86M H 2.20 M	D = 52.86 M H= 2.00 M
MS 25	80.00	66.40	4.85	5.05	4.50	4.80	4.10	5.05	78.22	D = 50.70 M H = 2.08 M	D = 200.20 H=1.50 M
MS 26	85.00	44.10	4.10	5.80	6.00	5.10	3.90	6.00	63.20	D = 27.05 M H = 1.50 M	D =192.05 M H= 1.70 M
MS 27	90.00	54.35	4.90	5.52	3.90	3.65	2.85	5.52	61.24	Nil	D = 97.88 M H= 1.60 M
MS 28	94.00	60.10	4.00	4.75	4.50	3.12	2.77	4.75	58.65	Nil	Nil
MS 29	99.00	45.40	2.92	4.30	4.46	4.05	3.10	4.46	48.40	Nil	Nil
MS 30	0.00	70.20	4.10	4.70	7.33	5.20	4.10	7.33	82.43	Nil	Nil
MS 32	6.00	65.30	4.60	5.30	7.80	6.20	5.80	7.80	95.19	Nil	Nil
MS 33	9.00	63.00	5.10	5.75	8.80	4.95	4.05	8.80	87.04	Nil	Nil

TABLE 2.10 Flow area Details of Longai River system-Contd

Name of station	Distance from Bangladesh border(Latu Bridge)	Maximum top width (T) in (M)	Vertical depth (m)					Maximum depth(m)	flow area (Approx) in Sq.m	Embankment Details	
			1/6.T	2/6.T	3/6.T	4/6.T	1/6.T			R Bank	L Bank
MS 34	12.00	57.50	4.80	5.95	8.95	6.83	5.50	8.95	92.81	Nil	Nil
MS 35	16.00	63.70	4.30	5.20	6.30	5.90	4.98	6.30	84.06	Nil	Nil
MS 36	18.00	58.80	4.90	5.80	7.40	6.20	5.40	7.40	89.27	Nil	Nil
MS 37	20.00	65.30	3.90	5.80	8.40	6.85	5.75	8.40	94.61	Nil	Nil
MS 38	22.00	57.20	2.95	4.52	4.85	3.80	3.10	4.85	55.18	Nil	Nil

Flood Damage Mitigation: Report

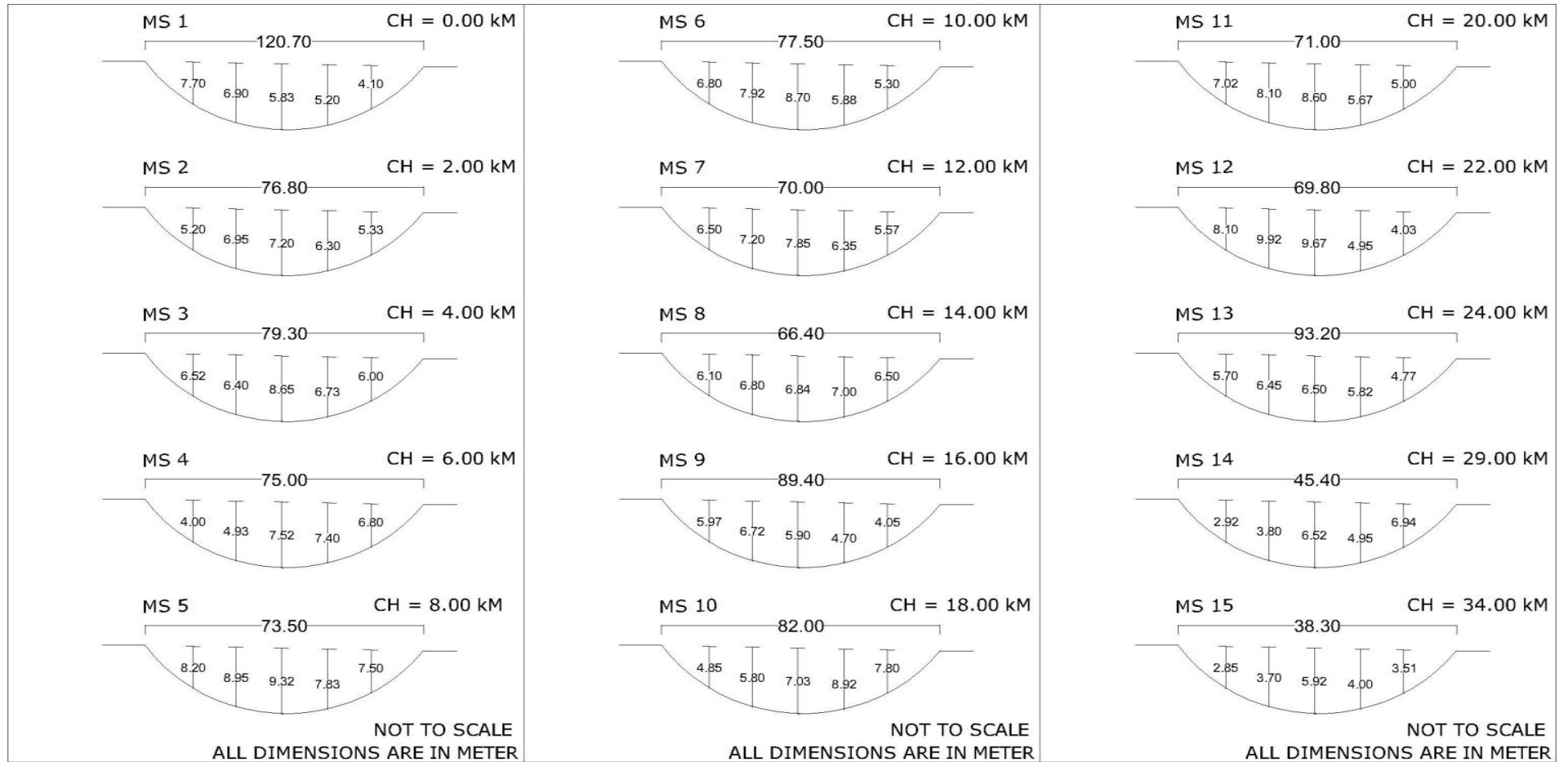

FIGURE 2.20(a) Section Details of Longai River system

Flood Damage Mitigation: Report

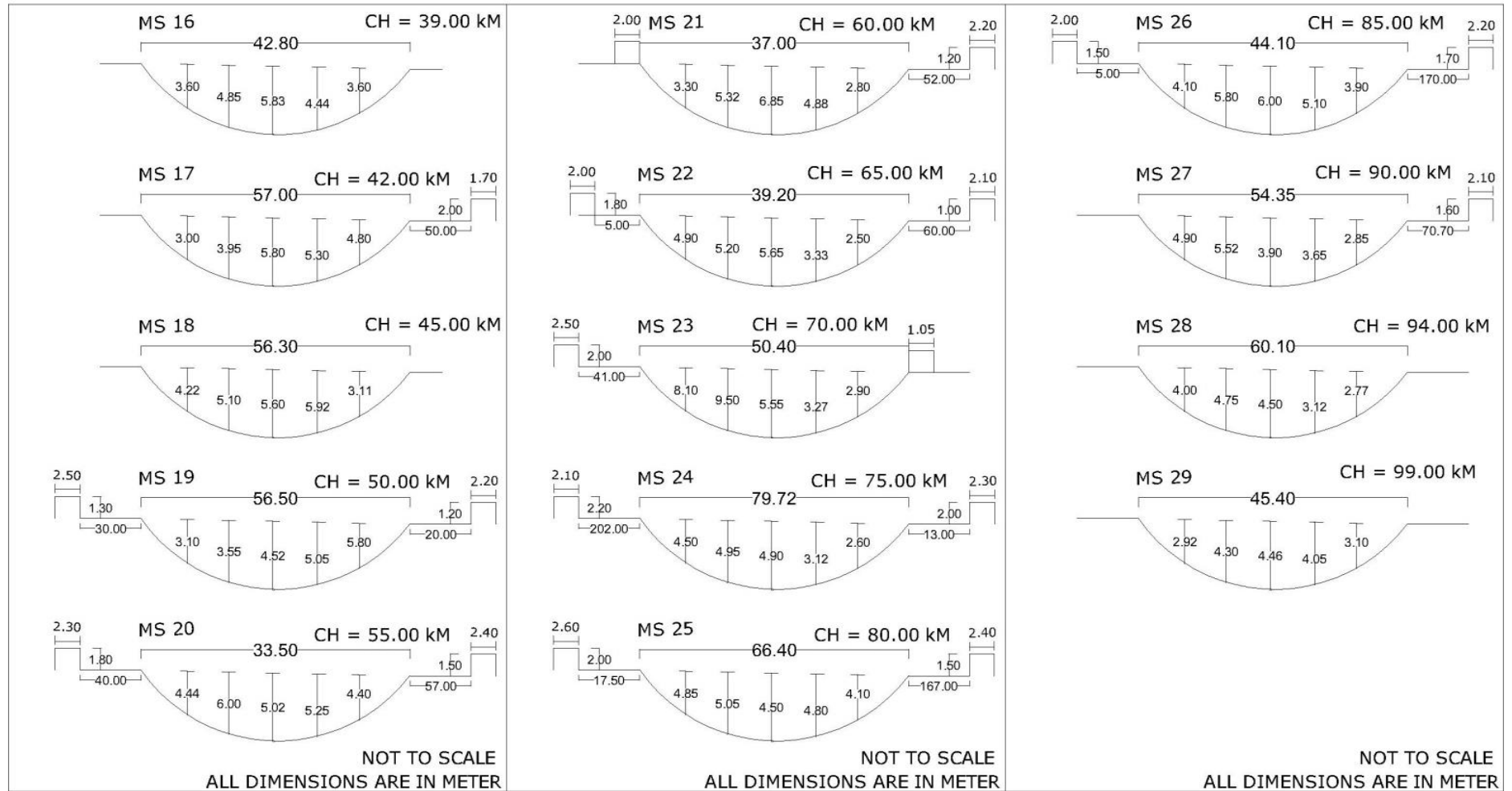

FIGURE 2.20 (b) Section Details of Longai River system-contd

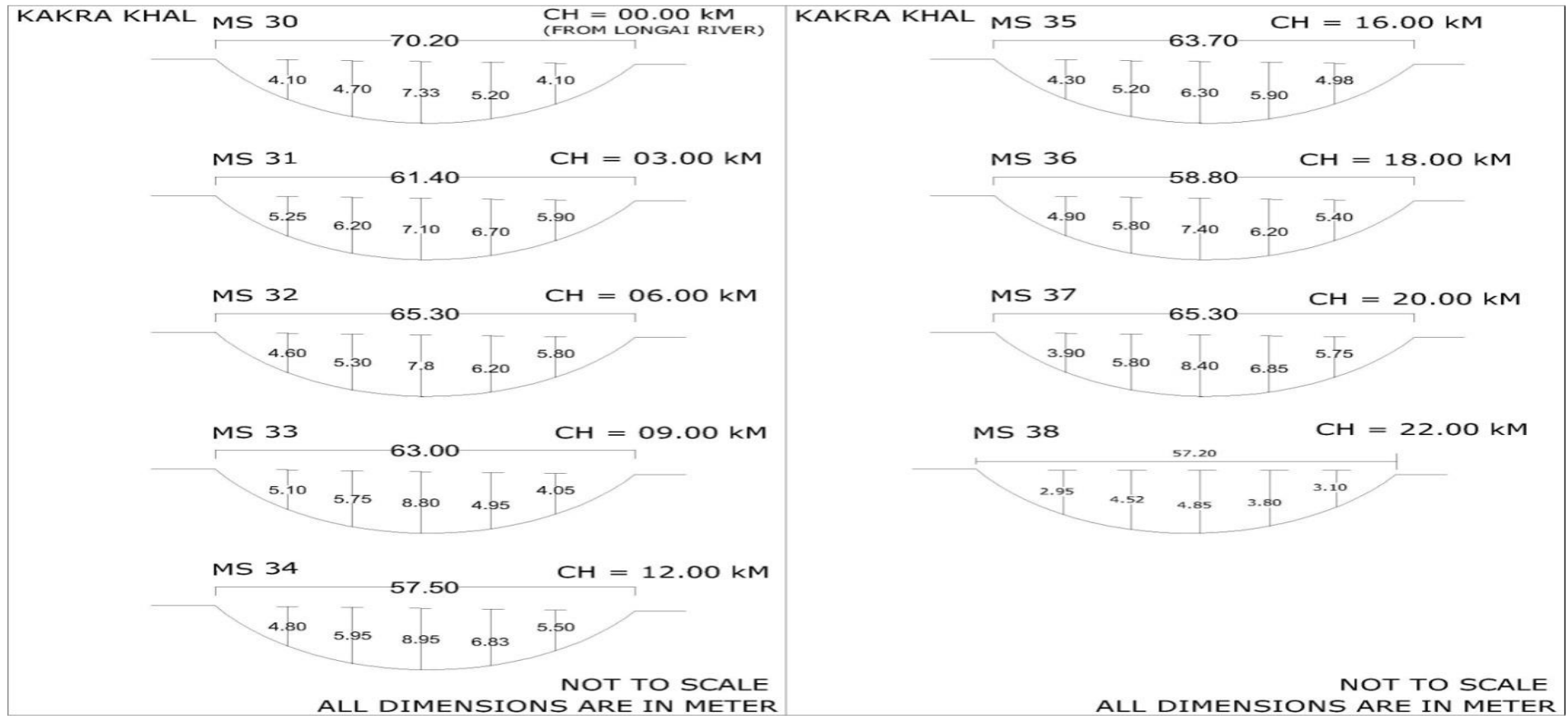

FIGURE 2.20(c) Section Details of Longai River system-contd

TABLE 2.11 Details of the existing embankment

Name of the river - Barak

Left bank			Right bank		
From	to	Approx length	from	to	Approx length
Dilcush village	Rajnagar	84 Km	Barenga	Masughat	42 Km
			Ujan Gram	Katigorah	40 km

Name of the river - Rukni

Left bank			Right bank		
From	To	Approx length	from	to	Approx length
Baga	Nadir gram	30.50 Km	Gagla ghat	Roy para	24 Km

Name of the river - Sonai

Left bank			Right bank		
From	To	Approx length	from	to	Approx length
Borali basti	Jarul gram toal	33.50 Km	Amraghat	Dungir par	38.00 Km

Name of the river - Badri

Left bank			Right bank		
From	To	Approx length	from	to	Approx length
Mach para	Badri basti	2.00 Km	Old lakhipur road	Machpara	1.50 Km

Name of the river - Madhura

Left bank			Right bank		
From	To	Approx length	from	to	Approx length
Rongpur	Istampur	14.00 Km	Dudhpatil	Pachmile	8.00 Km

Name of the river - Gagra

Left bank			Right bank		
From	To	Approx length	from	to	Approx length
Rothur gram	6 A.P camp	19.50 Km	Suktara	Srikona	2.00 Km

Name of the river -jatinga

Left bank			Right bank		
From	To	Approx length	from	to	Approx length
Badripar	dolu	3.00 Km	-	-	-

Name of the river -katakhal

Left bank			Right bank		
From	To	Approx length	from	to	Approx length
kaligange	Rupacherra	71.00 Km	kaligange	Rupacherra Bagan	71.00 Km

Name of the river -Longai

Left bank			Right bank		
From	To	Approx length	from	to	Approx length
Gandhri	Baitar Ghat	57.00 Km	Nilambazer	buringa	49.00 Km

TABLE 2.12 Details of existing major sluice gates in Barak Valley

SI no.	Sluice Gate	River/ Channel	Outfall
1.	Surface Sluice(Five Openings)	Suktara Channel	Ghagra
2.	Larsing Sluice(Single Opening)	Larsing Channel	Madhura
3.	Paku Sluice(Double Opening)	Amjur River	Sonai
4.	Boile Badri(old)(Double shutter)	Bolie Badri	Jatinga
5.	Boile Badri(new)(Double shutter)	Bolie Badri	Jatinga
6.	Punir Mukh Sluice(Duoble Shutter)	Rukni River	Rukni
7.	Rangirkhari Sluice (Single Shutter)	Rangirkhari Channel	Ghagra
8.	Purkhai Sluice(Single Shutter)	Purkhai	Borak
9.	PirNagar Sluice gate (multiple Shutter)	Baleshwar	Surma
10.	Sluice gate (Village Muraure)	Churia Jhumjhumi Channel	-
11.	Pola Sluice(Shutters:4 nos)	Pola Chnnel	Barak
12.	Hatia Diversion Sluice(Single Shuttter)	Dhaleshwar	Dhaleshwar
13.	Lalatal Sluice (Shutters:2 nos)	Katakhal River	Katakhal

3.0 Rainfall Analysis:

The Barak Valley is situated in the southern part of Assam and consists of Cachar, Hailakandi and Karimganj districts. The entire area of this valley lies within the hydro-meteorological Sub-Zone 2(C) of India. Reliable rainfall frequency analysis for the sites can be carried out if the available data are of longer periods as compared to the desired return periods. In order to gather rainfall affecting information from those of the ungauged areas roughly 14 numbers of (1° latitude X 1° longitude) grid points are selected to cover the entire study area. The large scale atmospheric variables affecting rainfall and seasonality of rainfall data for each of the grid points are extracted from NCEP Operational Plotting Page (www.esrl.noaa.gov/psd/data/hisdata/) and GPCP Precipitation Data Set (www.esrl.noaa.gov) which are used along with the location parameters (latitude and longitude) as attributes for the regionalization of the Sub-Zone into two homogeneous regions by Fuzzy c-means clustering. The use of large scale atmospheric variables as attributes can form reliable regions than the use of site data alone because these variables give information from the ungauged areas. The two delineated regions are tested for discordancy and regional homogeneity using the site data available in the grid points. L-moment based index-rainfall approach (Hosking and Wallis 1990, 1993, 1997) is used for the rainfall frequency analysis of this Valley. In case of the gauged sites a regional rainfall frequency relationship for the estimation of rainfall of various return periods was derived using the selected distributions whereas for those of the ungauged sites a regional mean rainfall relationship with latitude and longitude of the sites was developed using multiple linear regression. The objectives of this study is to conduct regional extreme rainfall frequency analysis for Barak Valley of India using L-moments approach.

3.1 Study Area and Data Collection

This study area lies within 22° N to 27° N and 90° E to 95° E which covers the states of Meghalaya, Manipur, Nagaland, Mizoram, Tripura, North Cachar Hills and Barak Valley of Assam. The entire study area can be roughly covered by 14 numbers of 1° Latitude x 1° Longitude grid points. The maximum annual daily rainfall data from 1990 to 2010 for 13 nos. of stations in this valley are

collected from Regional Meteorological Centre, Gauwahati. The 14 grid points with the stations in the grid are in Table 14. The gridded ($1^{\circ} \times 1^{\circ}$) large scale atmospheric variables affecting rainfall in the grids of the study area are extracted from NCEP (National Centre for Environmental Prediction) Operational Plotting Page (www.esrl.noaa.gov/psd/data/hisdata/) and gridded (1° latitude x 1° longitude) precipitation data from Global Precipitation Climatory Centre (www.esrl.noaa.gov).

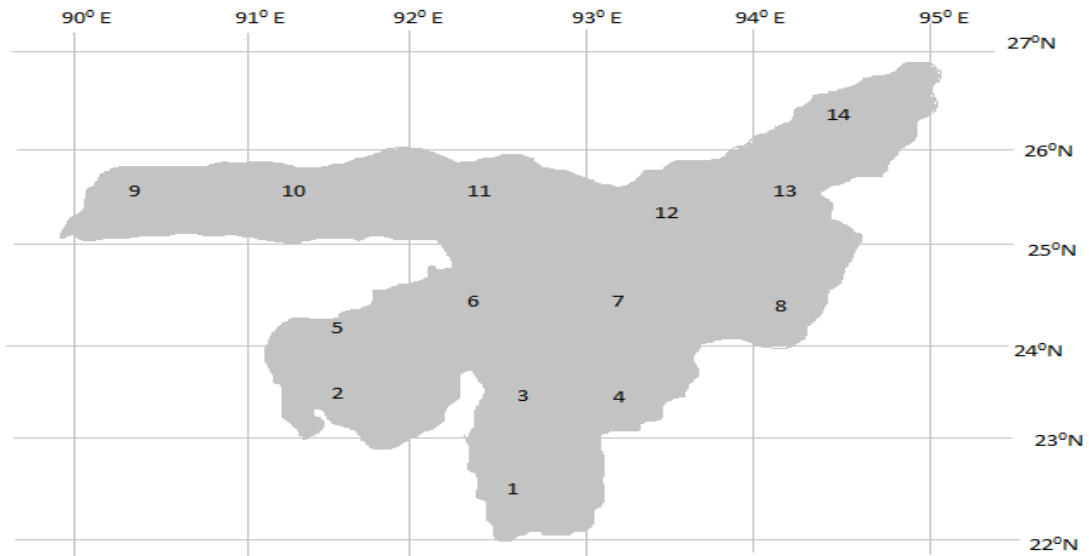

FIGURE 3.1 Grid Points Covering the Study Area

TABLE 3.1 Rainfall gauging station in the selected Grids

Grid Points	Latitude Longitude	Stations in the Grid	Latitude	Longitude	Length of Record
1	22 ⁰ N x 23 ⁰ N 92 ⁰ E x 93 ⁰ E	1.Lengpui	22.88 ⁰ N	92.75 ⁰ E	10
2	23 ⁰ N x 24 ⁰ N 91 ⁰ E x 92 ⁰ E	2.Agartala	23.88 ⁰ N	91.25 ⁰ E	21
3	23 ⁰ N x 24 ⁰ N 92 ⁰ E x 93 ⁰ E	3.Aizwal	23.73 ⁰ N	92.71 ⁰ E	21
4	23 ⁰ N x 24 ⁰ N 93 ⁰ E x 94 ⁰ E	-			
5	24 ⁰ N x 25 ⁰ N 91 ⁰ E x 92 ⁰ E	4.Kailashahar	24.31 ⁰ N	92.00 ⁰ E	20
6	24 ⁰ N x 25 ⁰ N 92 ⁰ E x 93 ⁰ E	5.Gharmura	24.36 ⁰ N	92.53 ⁰ E	21
		6.Karimganj	24.86 ⁰ N	92.35 ⁰ E	21
		7.Dholai	24.58 ⁰ N	92.85 ⁰ E	21
		8. Silchar	24.81 ⁰ N	92.80 ⁰ E	21
7	24 ⁰ N x 25 ⁰ N 93 ⁰ E x 94 ⁰ E	9. Imphal	24.76 ⁰ N	93.90 ⁰ E	21
8	24 ⁰ N x 25 ⁰ N 94 ⁰ E x 95 ⁰ E	-			
9	25 ⁰ N x 26 ⁰ N 90 ⁰ E x 91 ⁰ E	-			
10	25 ⁰ N x 26 ⁰ N 91 ⁰ E x 92 ⁰ E	10. Shillong	25.56 ⁰ N	91.88 ⁰ E	21
		11. Cherrapunji	25.25 ⁰ N	91.73 ⁰ E	21
		12. Mawsynram	25.30 ⁰ N	91.58 ⁰ E	14
11	25 ⁰ N x 26 ⁰ N 92 ⁰ E x 93 ⁰ E	-			
12	25 ⁰ N x 26 ⁰ N 93 ⁰ E x 94 ⁰ E	-			
13	25 ⁰ N x 26 ⁰ N 94 ⁰ E x 95 ⁰ E	13.Kohima	25.63 ⁰ N	94.16 ⁰ E	21
14	26 ⁰ N x 27 ⁰ N 94 ⁰ E x 95 ⁰ E	-			

3.2 L-moments Approach:

L-moments are linear combinations of probability weighted moments (PWM). The probability weighted moments are calculated from the ranked observations $X_1 > X_2 > X_3 \dots \dots \dots > X_n$. Greenwood et al (1979) summarizes the theory of probability weighted moments and defined them as

$$b_r = N^{-1} \sum_{j=r+1}^N (x_j) \frac{(j-1)(j-2)\dots\dots\dots(j-r)}{(N-1)(N-2)(N-3)\dots\dots\dots(N-r)}$$

The first four L-moments are

$$\lambda_1 = \beta_0 \lambda_2 = 2 \beta_1 - \beta_0 \lambda_3 = 6 \beta_2 - 6\beta_1 + \beta_0 \lambda_4 = 20 \beta_3 - 30\beta_2 + 12 \beta_1 - \beta_0$$

where λ_1 is the L-mean which measures the central tendency, λ_2 is the L-standard deviation which measures the dispersion. Again, (Hosking, 1990) defined the dimensionless L-moment ratios

$$\tau = \text{L- coefficient of variance, L-cv} = \frac{\lambda_2}{\lambda_1}, \quad \tau_3 = \text{L- skewness} = \frac{\lambda_3}{\lambda_2}, \quad \tau_4 = \text{L- kurtosis} = \frac{\lambda_4}{\lambda_2}$$

3.3 Discordancy measure

Hosking & Wallis (1993) defined discordancy measure of sites to detect the discordance sites among other sites as $D_i = \frac{1}{3} (u_i - \bar{u})^T A^{-1} (u_i - \bar{u})$ where, $u_i = (\tau, \tau_3, \tau_4)^T$ is a vector containing τ, τ_3, τ_4 values of site i, the superscript T denotes transpose of a matrix or vector,

$\bar{u} = \frac{1}{N} \sum u_i$ be the (unweighted) group average of u_i , A^{-1} is the inverse of the covariance matrix A of u_i . The elements of A^{-1} are given by the relation,

$$A = \frac{1}{N} \sum_{j=1}^N (u_j - \bar{u})(u_j - \bar{u})^T, \text{ where N is the number of sites in the region.}$$

The discordancy (D_i) of the 13 sites are determined and the station Lengpui has its D_i value greater than the critical value of 2.869 for 13 stations. The valley has to be sub-divided into regions to see whether the D_i value of this site can be adjusted below the critical value by combining with some other sites and

to form hydrologically similar homogeneous regions using Fuzzy c-means clustering.

3.4 Fuzzy c-means clustering -

In this study Fuzzy c-means clustering is carried out in MATLAB using large scale atmospheric variables affecting rainfall, location parameters and seasonality of rainfall as attributes. Two regions are formed by assigning the membership of each grid points in the clusters equal or greater than to a threshold; $T_i = \max \left\{ \frac{1}{c}, \frac{1}{2} [\max (\mu_{ij})] \right\}$, where c = no. of clusters and μ_{ij} = maximum membership of the i^{th} grid point in the j^{th} cluster. These two regions consist of grid point 1 to 5 in region I and 6 to 14 grid points in region II. The D_i values for the sites in the two regions are less than their respective critical values i.e. 1.333 for Region I and 2.329 for Region II which indicates that there are no discordance sites.

Annual maximum rainfall intensity for the rain gauging stations in the valley for last 21 years from 1990 to 2010 is collected from RMC Guwahati. The annual maximum rainfall in recorded for various station are used to estimate 10,20,30,40,50,75 and 100 year return period rainfall intensity for the gauging stations. Estimation of extreme rainfall intensity for this valley is obtained from the regional extreme rainfall frequency analysis of the sub-zone. Here, L-moments based regional frequency analysis approach is used. The discordancy (D_i) measure for screening out the data of the unusual sites was conducted. Fuzzy c-means clustering analysis with location parameters, seasonality of rainfall and large scale atmospheric variables affecting rainfall in the study area was used as attributes for regionalization of the Sub-Zone into homogeneous regions. Heterogeneity measure has been conducted by carrying out 500 simulations using a 4-parameter Kappa distribution. Five extreme value distributions Generalized Pareto (GPD), Generalized Logistic (GLO), Generalized Extreme Value (GEV), Pearson Type III and Log Normal (LN3) were used to select the best fit distribution for the regions. Based on Z^{DIST} statistics and L-moment ratio diagrams GLO for region I and GPD for region II were selected as the best fit distributions. Regional rainfall formula for the estimation of rainfall for various return periods was derived for the gauged sites using the selected distributions and growth factors for the regions were derived. For the ungauged

sites a regional mean relationship with latitude and longitude of the sites were developed using multiple linear regression. Brief methodology applied in analyzing the extreme rainfall events is summarized below:

3.5 Brief Methodology:

L-moment approach analysis (Hosking & Wallis, 1990) consists of the following steps-

(a) Screening of data using a discordancy measure.

(b) Formation of homogeneous regions using clustering method and refinement by conducting homogeneity test.

(c) Choice of distribution using Goodness of fit test – Z^{DIST} statistics and L-moment ratio diagram.

(d) Establishment of rainfall frequency relationship using index-flood/rainfall method and Development of regional growth curves.

The discordancy (D_i) measure of the 13 sites are conducted and one of the sites has its D_i value greater than the critical value of 2.869 for 13 sites (Hosking & Wallis). To adjust this D_i value below the critical value and to include this site in the analysis, the study area has been clustered into two regions- region I comprising the grid points (1, 2, 3, 4 & 5) and region II comprising the grid points (6, 7, 8, 9, 10, 11, 12, 13 & 14) respectively using Fuzzy c-means clustering in MATLAB with large scale atmospheric variables affecting rainfall, location parameters and seasonality of rainfall as attributes and refinement by conducting homogeneity test. The heterogeneity measure has been conducted by carrying out 500 simulations using a 4-parameter Kappa distribution in a computer programme written in JAVA. From the result of Goodness of fit test using Z^{DIST} statistics and L-moment ratio diagram, GLO for region I and GPD for region II have been selected as the best fit distribution. The parameters of the selected distributions are estimated using L-moments and regional growth factors are derived by index-flood procedure (Dalrymple, 1960) with the development of regional rainfall formula for the two regions as –

Region I

$$X_T = [0.43096 + 0.50370 \left\{ \frac{(1-F)}{F} \right\}^{-0.26895}] \bar{X} \quad (3.1)$$

Region II

$$X_T = 1.69161 - 1.10411 (1 - F)^{0.59644} \cdot \bar{X} \quad (3.2)$$

Where, \bar{X} = at site mean rainfall, $F = (1 - \frac{1}{T})$ and T = return period.

T-year rainfall intensity for Barak Valley of Assam is carried out using (3.2) as this valley lies within region II.

TABLE 3.2 Estimated T-year rainfall intensity for Barak Valley

Station Year→	10	20	30	40	50	75	100
Silchar	170.17	181.05	185.63	188.26	190.01	192.66	194.19
Dholai	174.72	185.89	190.59	193.30	195.09	197.81	199.38
Karimganj	244.75	260.39	266.98	270.77	273.28	277.09	279.29
Gharmura	176.77	188.07	192.83	195.57	197.38	200.14	201.73

3.6 Development of Regional mean rainfall relationship -

The regional mean rainfall relationship is established by relating rainfall with latitude and longitude of the sites using matrix method of linear regression. The rainfall means for the observed data for the two stations in region II i.e. Cherrapunji and Mawsynram have extremely high values than the rest of all stations. So region II have been divided into two regions based on mean values and geographical locations of the grids as region II (a) comprising of grid points (6,7,8,12,13 and 14) and region II (b) comprising of grid points (9,10 and 11). Three linear equations have been developed as in (3.3), (3.4) and (3.5) for the estimation of mean rainfall for the sites in these regions.

$$\text{Region I} \quad \bar{X} = 2630.3 + 3.7(\text{Lat.}) - 28.1 (\text{Lon.}) \quad (3.3)$$

$$\text{Region II (a)} \quad \bar{X} = 2630.3 + 3.7(\text{Lat.}) - 28.1 (\text{Lon.}) \quad (3.4)$$

$$\text{Region II (b)} \quad \bar{X} = 2630.3 + 3.7(\text{Lat.}) - 28.1 (\text{Lon.}) \quad (3.5)$$

where (Lat.) is latitude and (Lon.) is the longitude for the site.

Regional mean rainfall for Barak Valley of Assam is estimated using (3.4) as this valley lies within region II (a).

TABLE 3.3 Estimation of mean rainfall using regional mean relationship

Station	Observed mean (Q)	Lat	Lon	Estimated mean(E)	$X^2 = \frac{\sum(Q-E)^2}{E}$
1. Silchar	128.58	24.81	92.80	144.84	1.8250
2. Dholai	132.02	24.58	92.85	133.44	0.0152
3. Karimganj	184.93	24.86	92.35	175.07	0.5556
4. Gharmura	133.57	24.36	92.53	145.79	1.0246
Chi- Square χ^2					3.4204

The Chi-Square values for the estimated mean and observed means for region II (a) is 3.4204 against the critical values of 7.815 at 95% significance level with 3 degrees of freedom. This shows that there is no significance difference between the estimated mean and observed mean.

4.0 Watershed Modeling:

4.1 Geographic Information System (GIS)

Geographic information system is an advanced software system engineered to enable creation, use, and management and sharing of geographic information viz.: geographic data set and data models, maps and globes, geoprocessing models and scripts, GIS methods and workflows and metadata. GIS combines a powerful visualization environment with a strong analytic and modeling framework that is rooted in the science of geography. GIS software supports several views for tackling with the geographic information categorized as the geodatabase view, the geovisualization view and geoprocessing view. In geodatabase view, GIS acts as a spatial database that connects datasets representing geographic information in terms of features, rasters, attributes, terrains, networks, etc. In geovisualization view, GIS acts as an advanced maps and other views that show features and feature relationships on the earth's surface which enable storing, querying, analyzing, and displaying of geospatial data. Lastly, in geoprocessing view it acts as information transformation tools that can extract new data set from existing information. These geoprocessing functions take information from existing datasets, apply analytic functions, and write results into new derived datasets. Geoprocessing also involves the ability to program and to automate a sequence of operation on geographic data to create new information. The ability of GIS to handle and process geospatial data in which the characteristics variables varies spatially distinguishes GIS from other information system. ArcGIS Desktop is a professional GIS application that comprises of three main software products: ArcView, ArcEditor, and ArcInfo which provides a scalable framework for implementing GIS techniques in prominent field like hydrology, environmental sciences, etc.

Applying GIS techniques DEM models for the entire Earth surface have been generated by different agencies that are available free of cost. The United States Geological Survey (USGS) is the primary distributor of The Shuttle Radar Topography Mission (SRTM), developed jointly by the National Aeronautics and Space Administration (NASA) and the National Geospatial Intelligence Agency (NGA), providing elevation datasets. The SRTM is projected into a geographic

coordinate system (GCS) with the WGS84 horizontal datum and the EGM96 vertical datum (USGS, 2006). The

Advanced Spaceborne Thermal Emission and Reflection Radiometer (ASTER) is an advanced multispectral imager that was launched on board **NASA's Terra spacecraft in December, 1999. The ASTER Digital Elevation Model (DEM) product is generated using bands 3N (nadir-viewing) and 3B (backward-viewing) of an ASTER Level-1A image acquired by the Visible Near Infrared (VNIR) sensor. Apart from the DEM developed by discretizing the top maps these DEMs though may have some imperfections can be used as an input to quantify the characteristics of the land surface after rectification**

4.2 Geomorphologic parameter estimation using GIS aided techniques

Estimation of geomorphologic parameters for a watershed can be achieved using different tools like hydrology, 3D analysis, Statistics, etc. in ArcGIS. These tools can be applied individually or used in sequence to create stream network to delineate watersheds. The process of estimation of geomorphologic characteristics of a watershed using GIS techniques involves the following sequential steps as shown in the chart given in the next page:

4.3 Development of Digital Elevation Model (DEM) for the watersheds:

Digital Elevation Model for the important watershed in the study area are developed using GIS technique by applying ArcGIS software. Generation of DEM using topographic map can be accomplished by following the steps and applying different GIS tools as shown in the above chart. Survey of India (SOI) provides topographic maps of different scales like 1:25,000, 1:50,000, etc. Topographic maps for the study area were collected from the office of Survey of India, Shillong. The maps were processed and brought to GIS environment in .tiff format. Using GIS software ArcGIS, coordinate system are defined for the topographic maps using suitable projected/ geographic coordinate system available in GIS software. The georeferenced map is used as input in GIS platform and contour digitization is done using Editing tool. The completed vector data of digitized contour is used with 3D analysis tool to generate Triangulated Irregular Network (TIN). Further using generated TIN as input in 3D analysis tool, DEM for the watersheds are generated. In the present study

DEM for Watersheds of Chiri, Jiri, Ghagar, Madhura, Jhatinga etc. are developed and given in the figures 4.2 to 4.6.

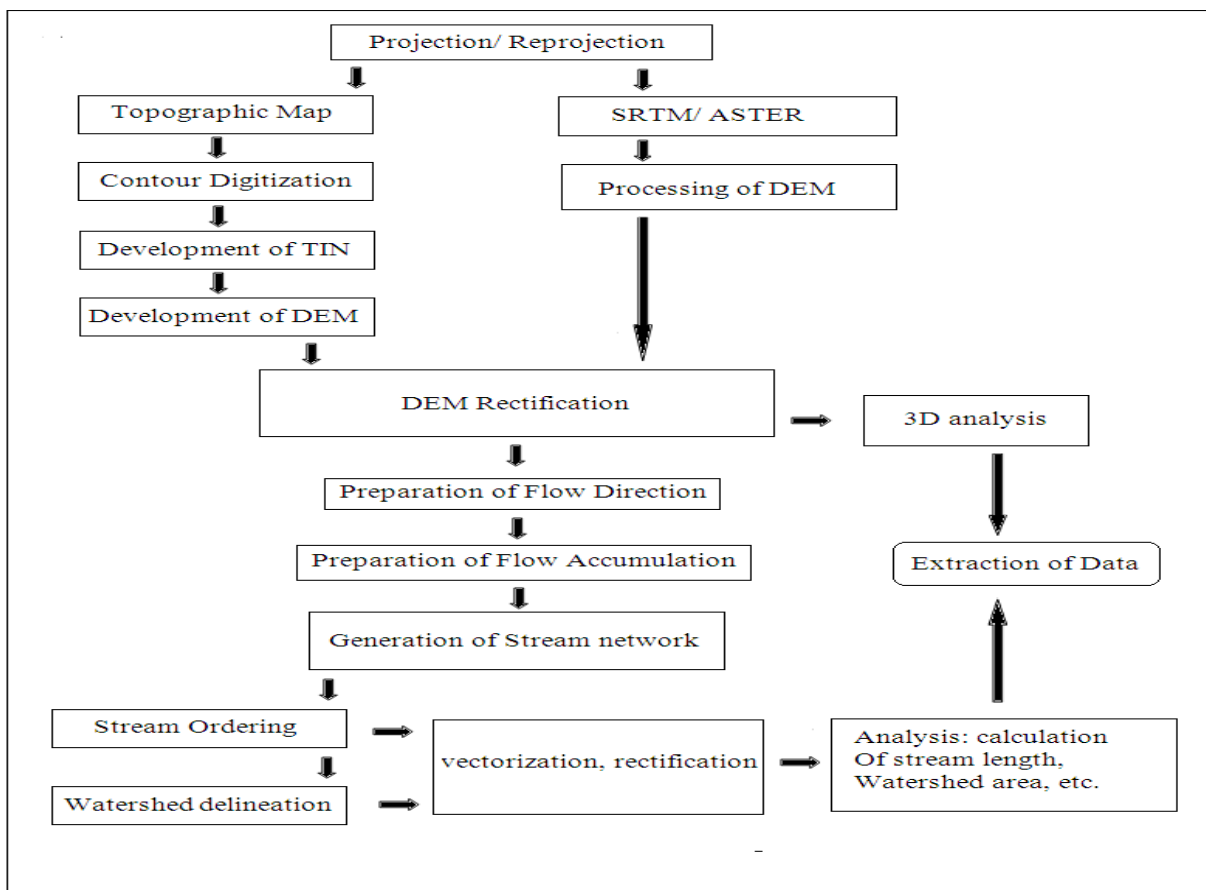

FIGURE 4.1 Flow chart for GIS application

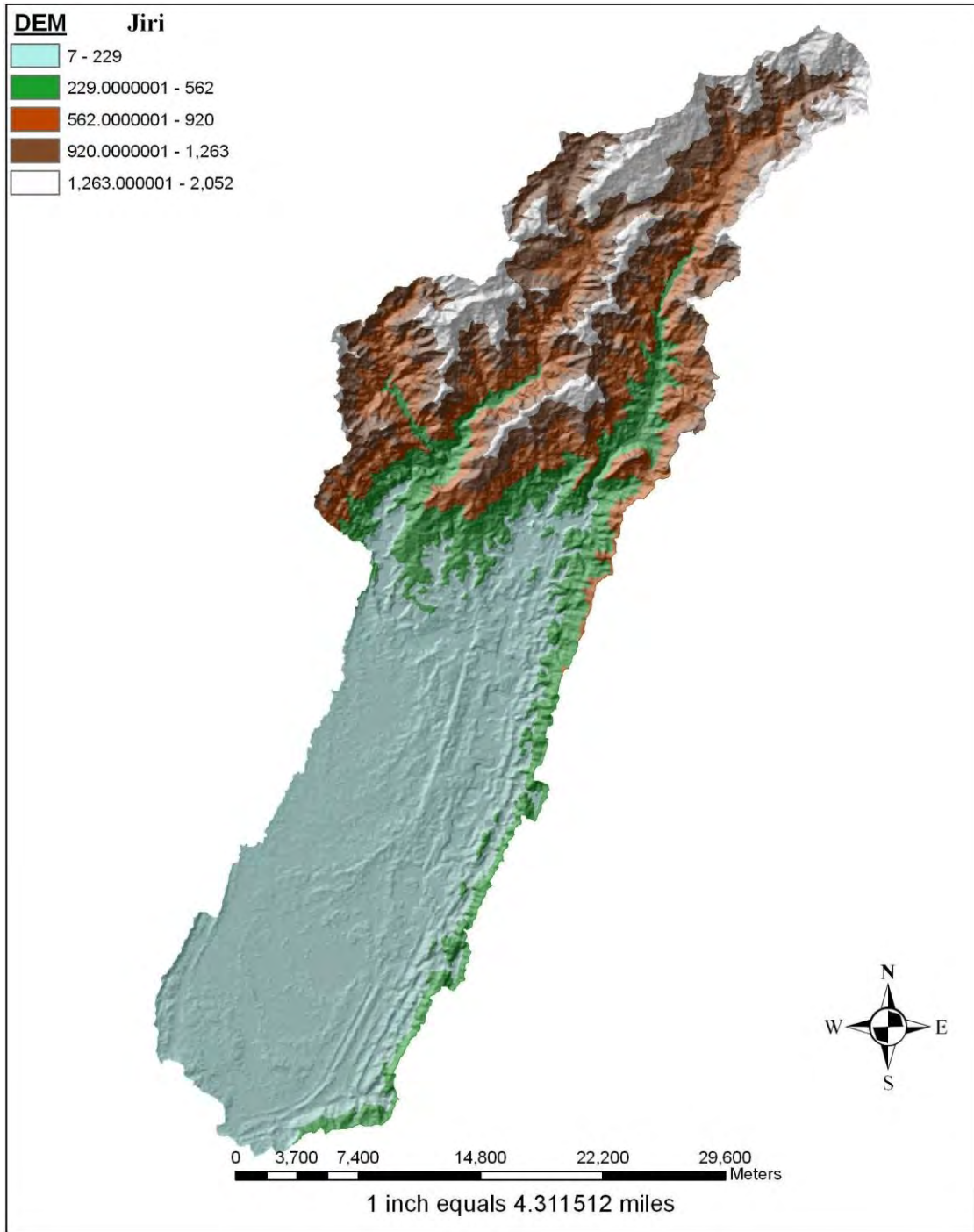

FIGURE 4.2 Digital Elevation Model of Jiri sub basin

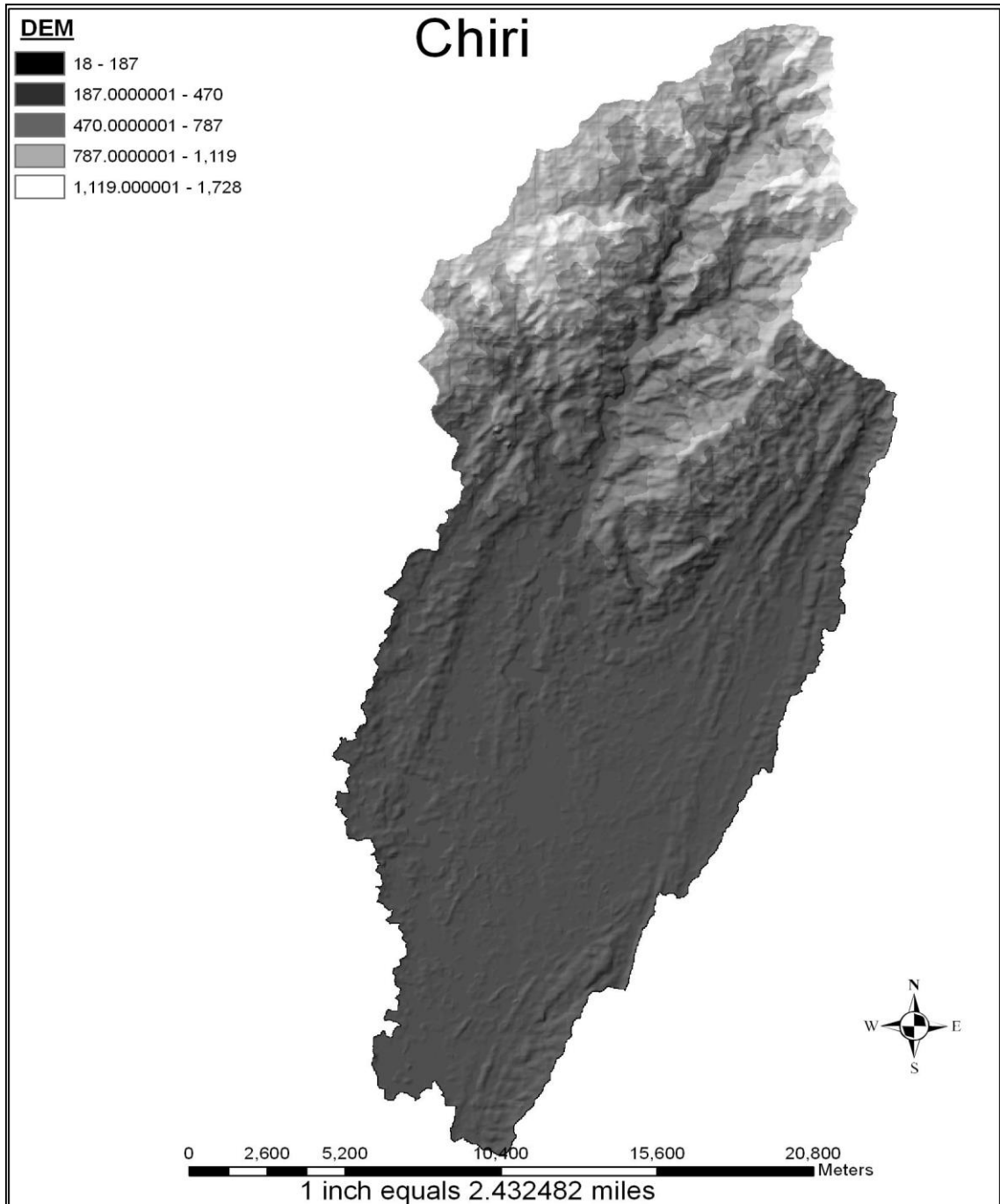

FIGURE 4.3 Digital Elevation Model of Chiri sub basin

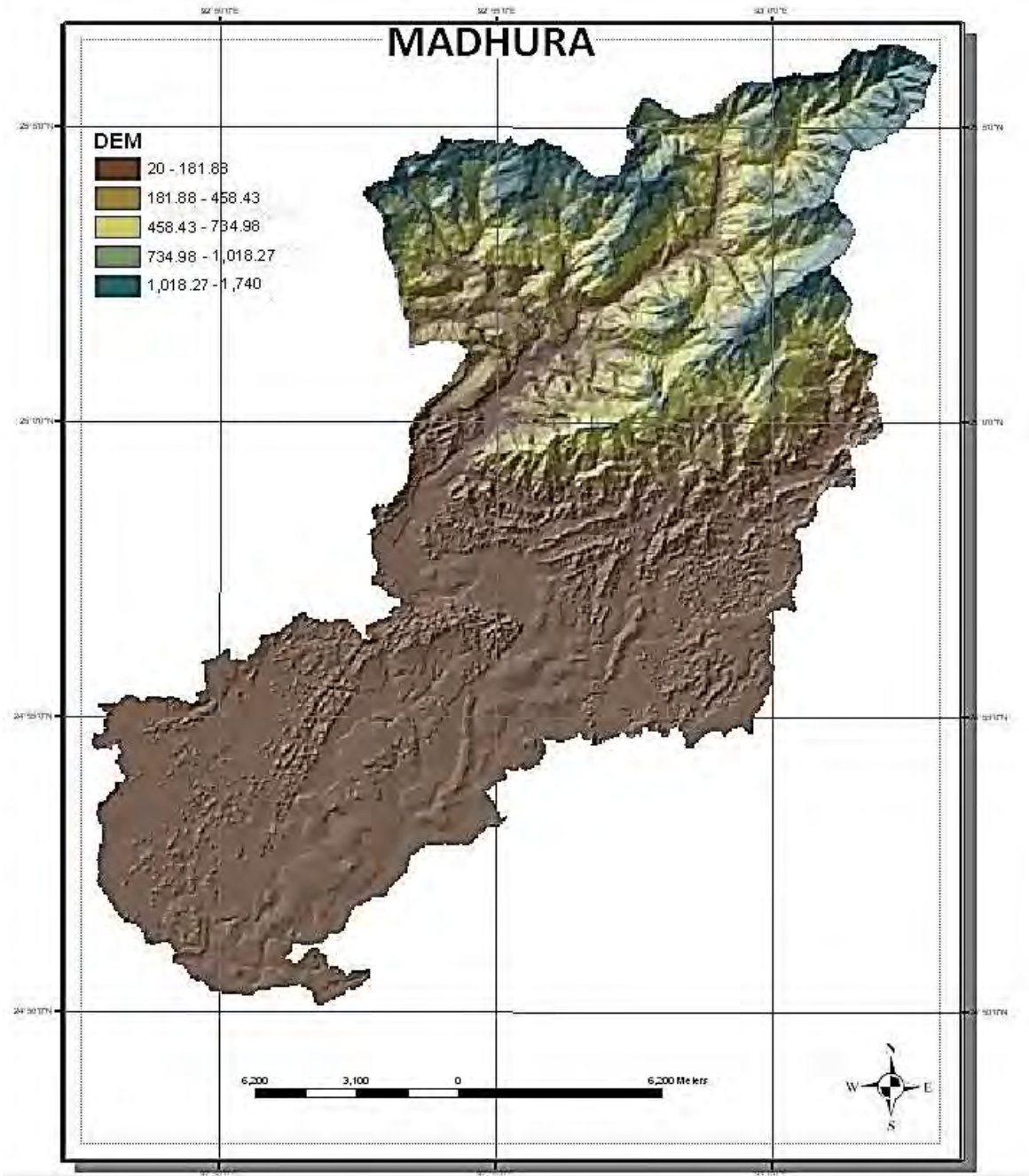

FIGURE 4.4 Digital Elevation Model of Madhura sub basin

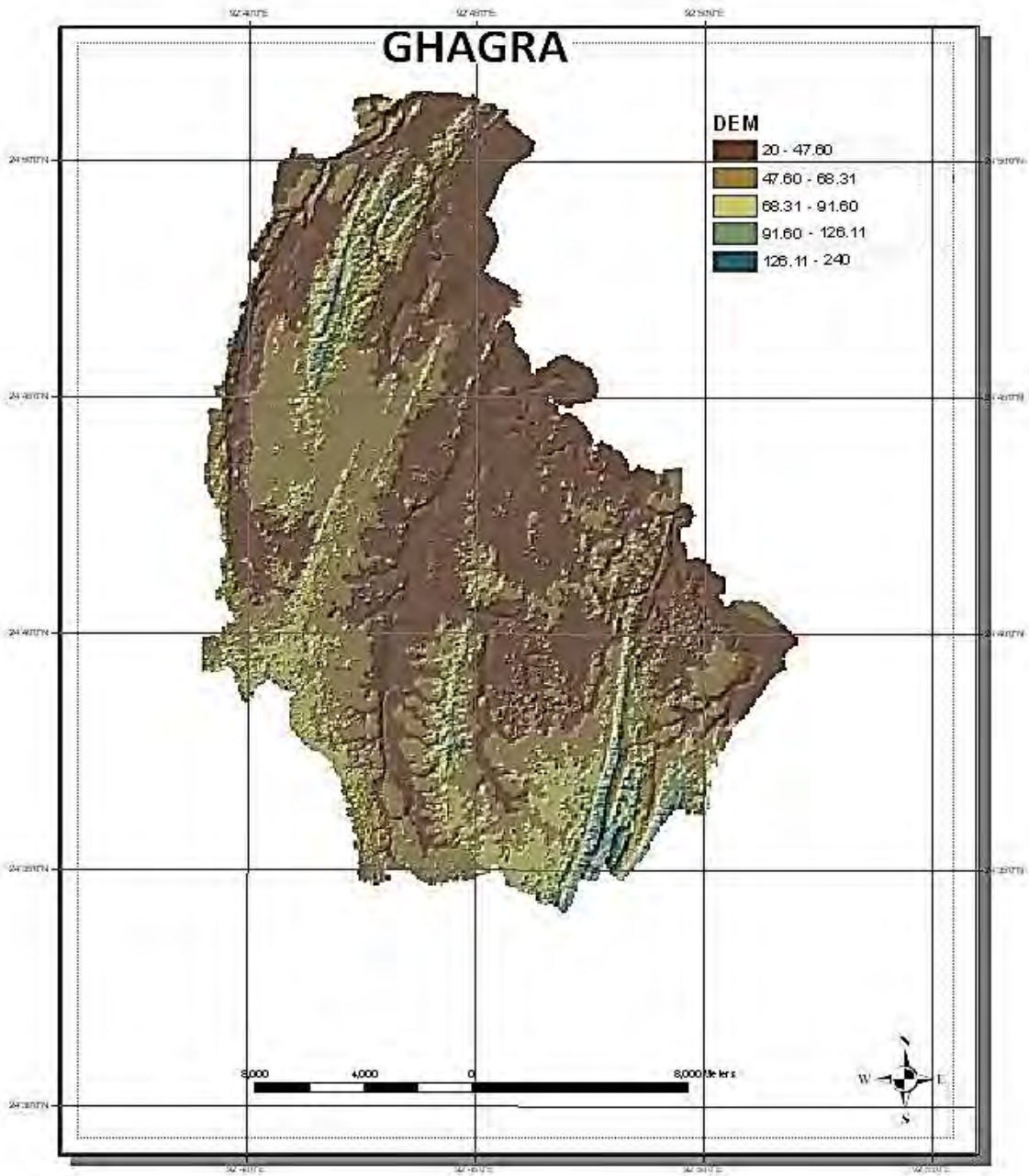

FIGURE 4.5 Digital Elevation Model of Ghagra sub basin

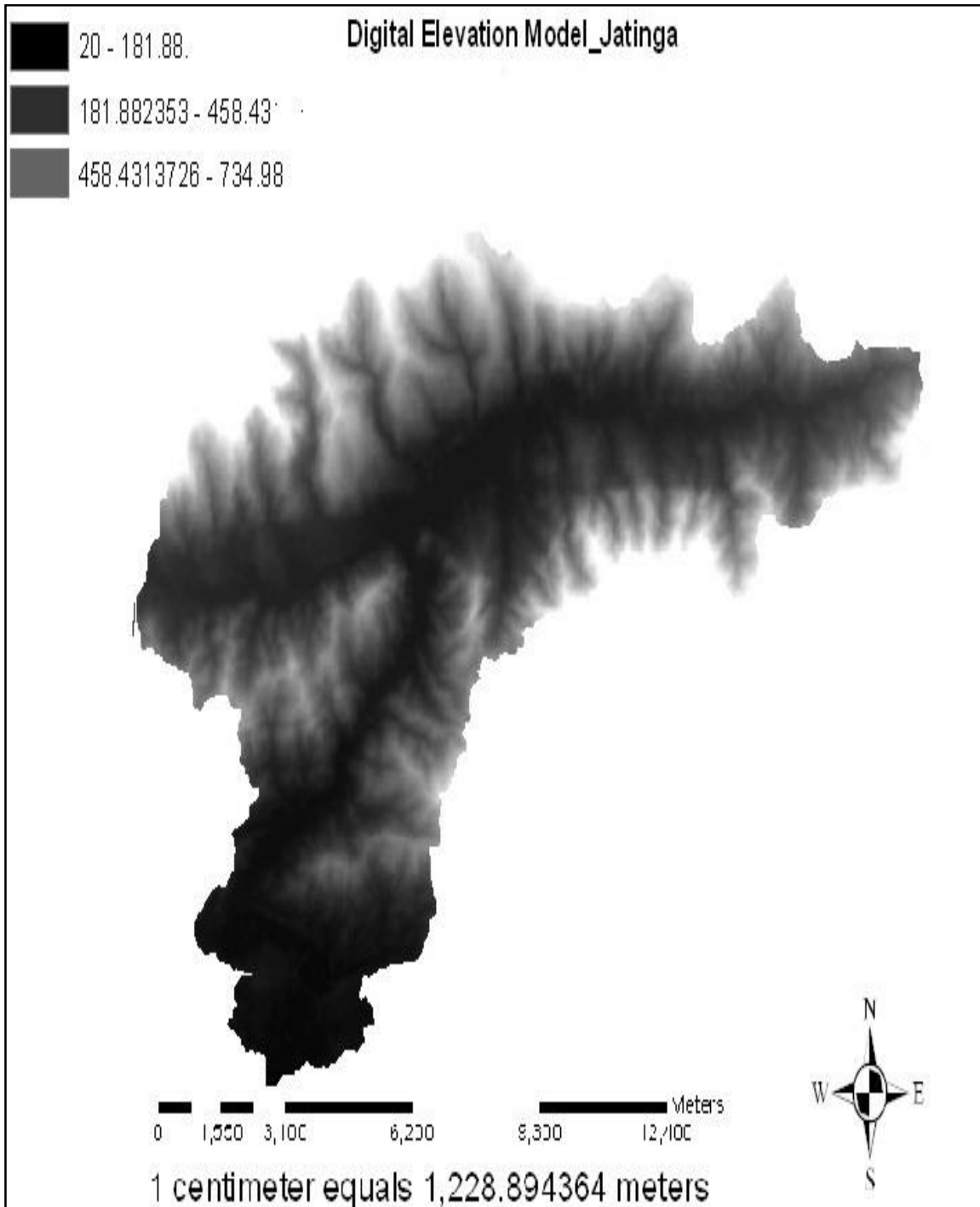

FIGURE 4.6 Digital Elevation Model of Jatinga sub basin

4.4 Development Stream Network for the watersheds

For watersheds in the study area the corresponding DEMs are used to develop the stream network for these watersheds. The generated DEM are analyzed using, Calculate statistic GIS tool taking the DEM as an input. The spatial analysis tool is used to develop depressionless DEM for the watersheds. Using the rectified DEM a raster of flow directions from each cell to its steepest downslope neighbor cell is created. Flow direction is generated using DEM as an input to Hydrology tool. The output of the flow direction tool is used to generate flow accumulation raster which is determined by accumulating the weight for all the cells that will flow into each cell. The generation of flow accumulation raster is achieved by using the generated flow direction raster as an input to Hydrology tool "flow accumulation". A threshold value that gives the minimum number of upslope cells contributing to a downstream cell is required. The stream network raster for the watersheds are generated using Map Algebra/ Conditional tool. The generated stream networks are ordered using Strahler stream ordering tool in the ArcGIS.. **It adopts Strahler' Stream ordering law** (Strahler, 1952) for ordering the stream network. In the Strahler ordering method, all streams with no tributaries are assigned an order of one and are referred to as first order. When two first-order streams intersect, the downslope stream is assigned an order of two. When two second-order streams intersect, the downslope stream is assigned an order of three, and so on. When two streams of the same order intersect, the order will increase. Strahler order method is the most common method used for ordering stream network. On the basis of the ordered stream network and flow direction map watershed area draining through different streams are delineated by using hydrology tool.

4.5 Generation of Slope map for watersheds using Topographic Map, SRTM/ASTER DEM.

The slope map of a watershed represents the degree of steepness (slope) of the watershed surface at different locations. The Slope map in slope percent for the watersheds is developed using rectified DEM in 3D analysis tool. Detailed description of the sub basins in the study area, drainage networks and slope map for the sub basins are presented in the tables and figures listed below.

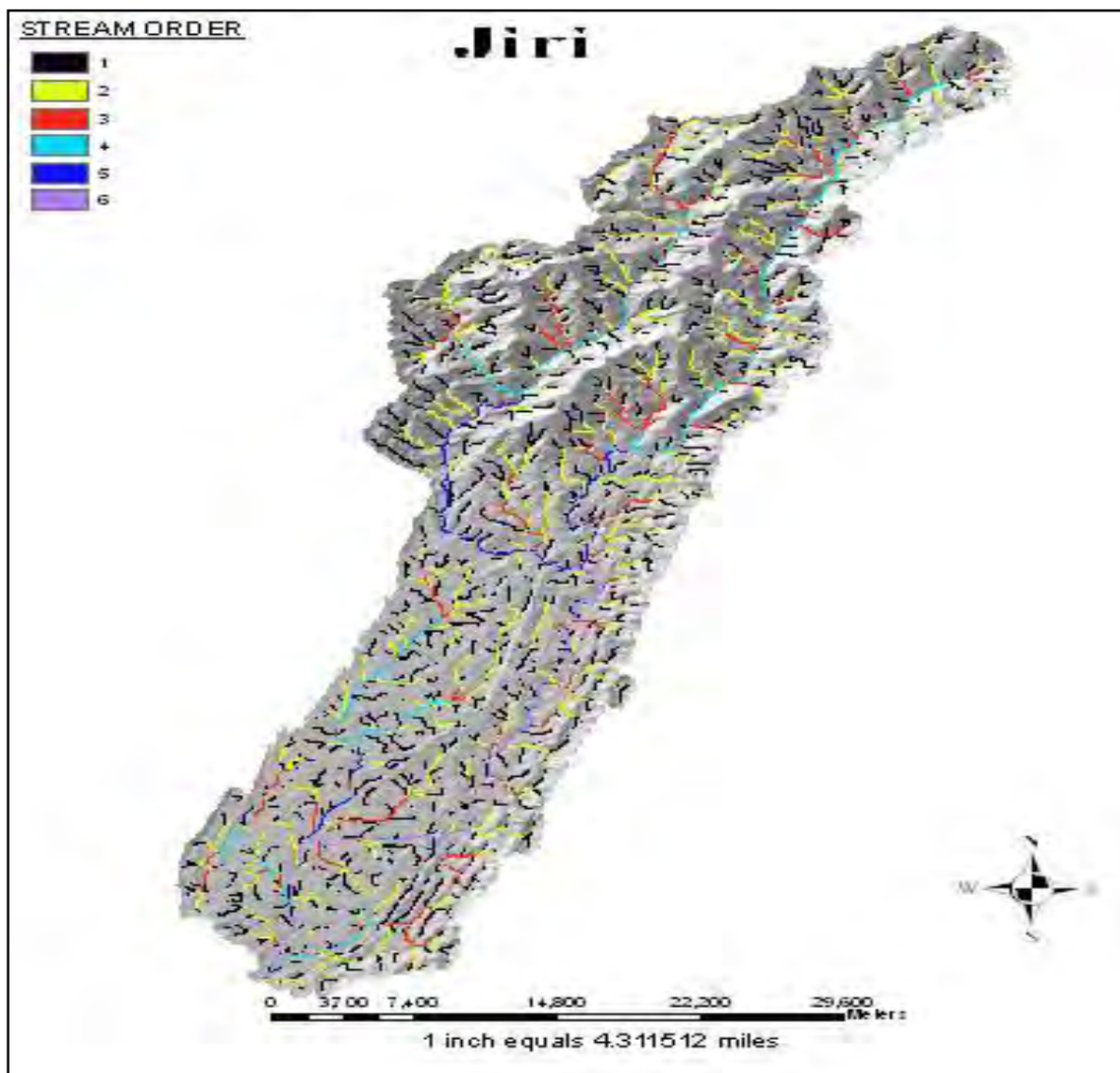

FIGURE 4.7 Drainage network in Jiri sub catchment

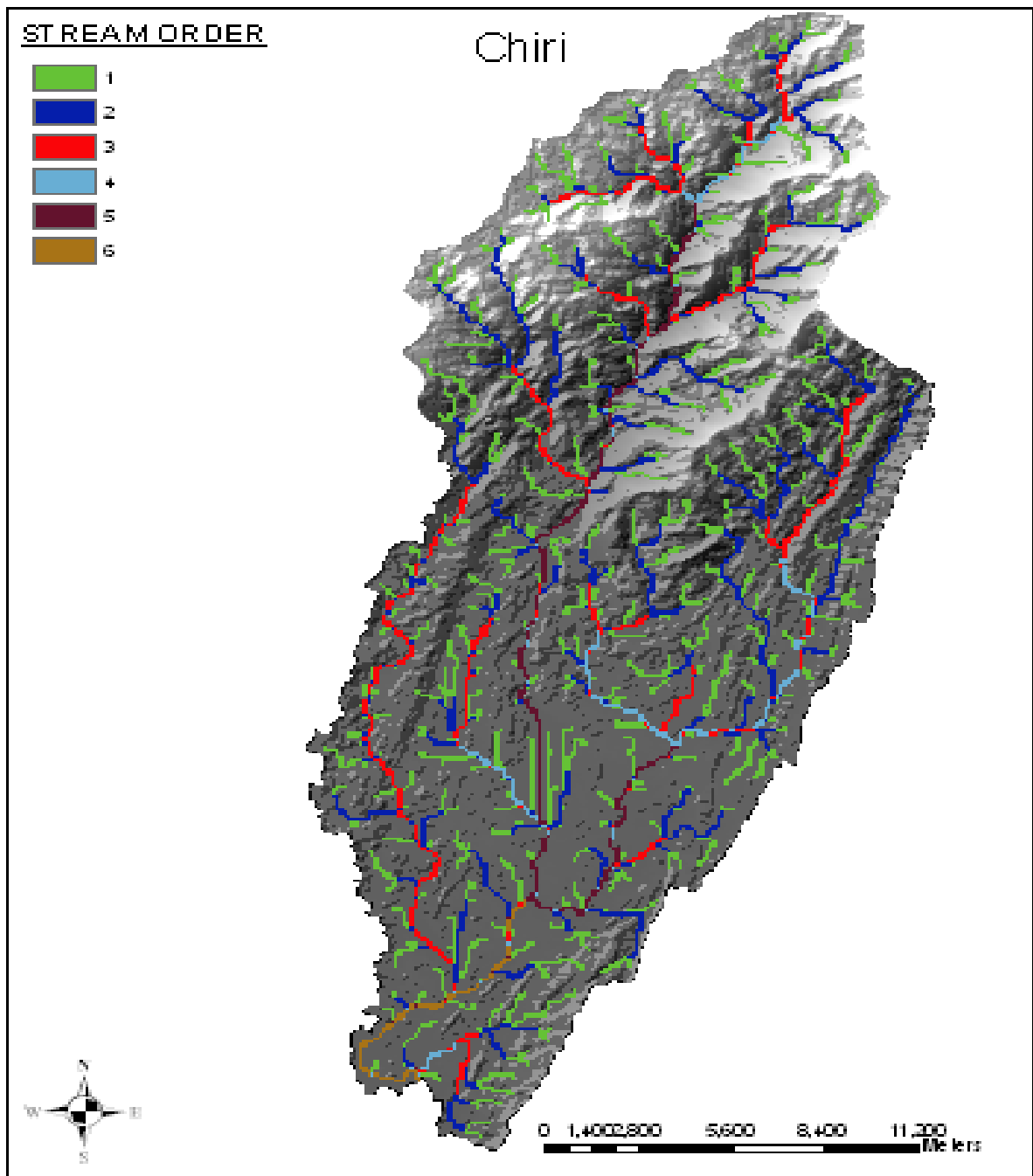

FIGURE 4.8 Drainage network in Chiri sub catchment

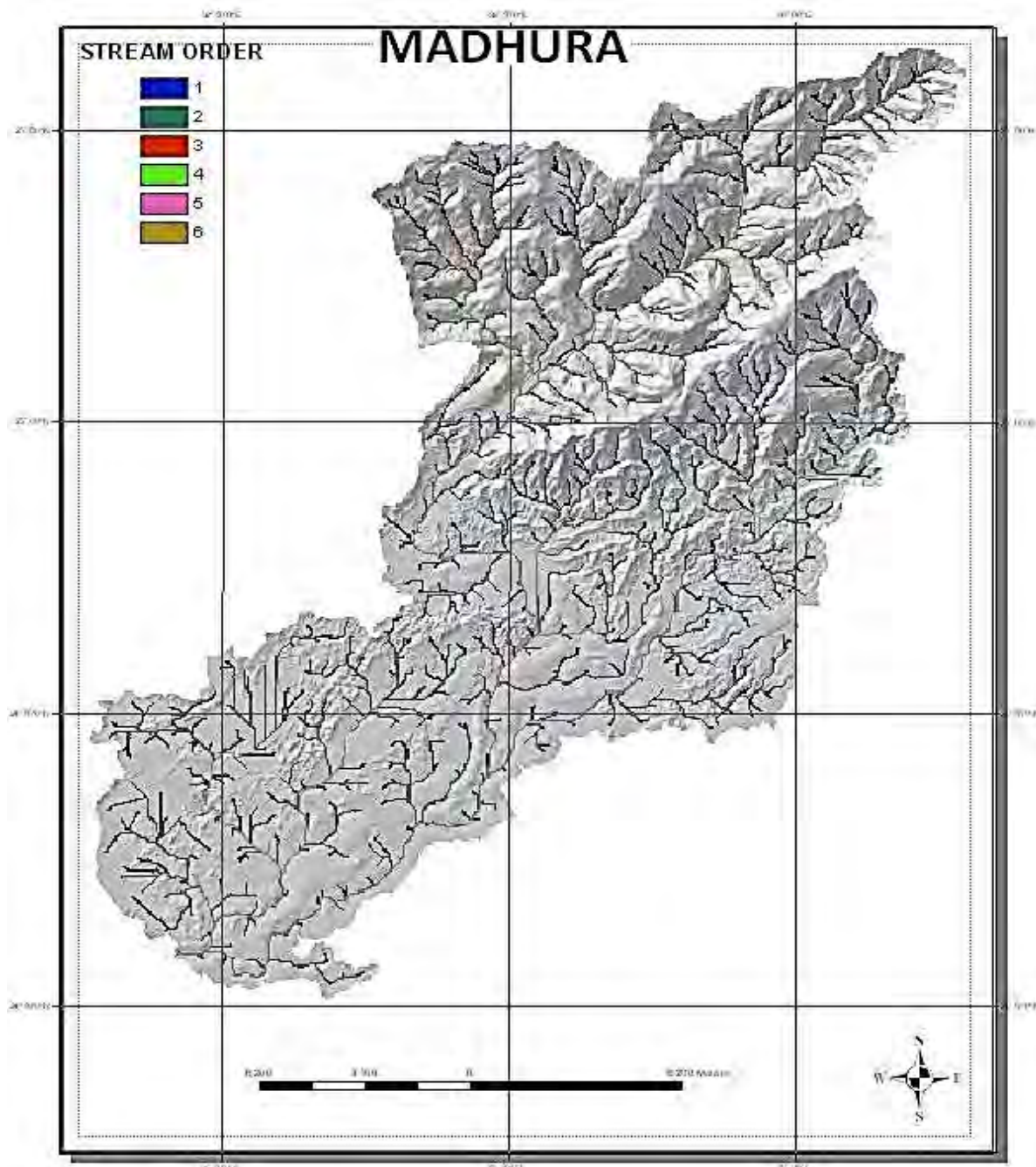

FIGURE 4.9 Drainage network in Madhura sub catchment

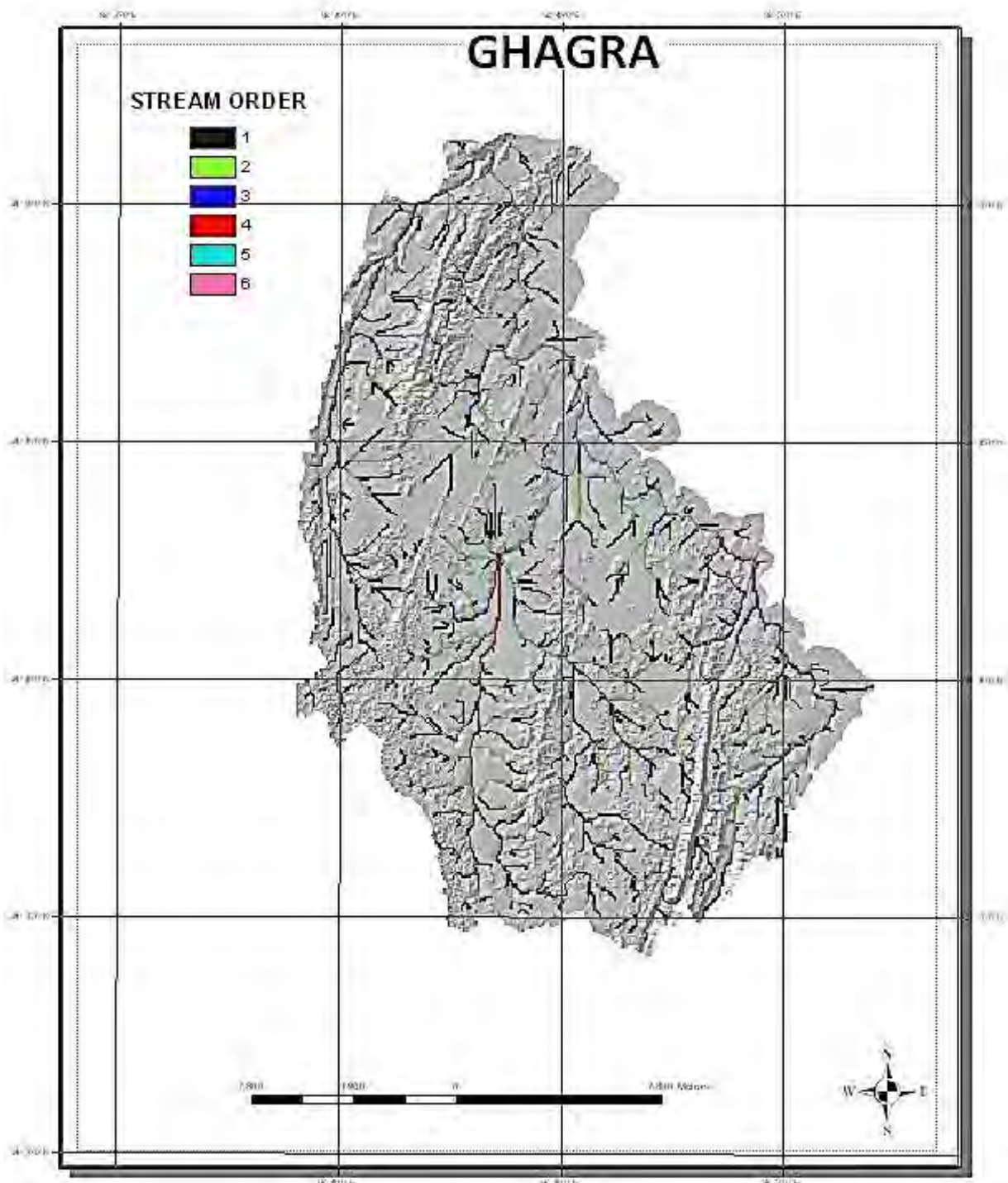

FIGURE 4.10 Drainage network in Ghagra sub catchment

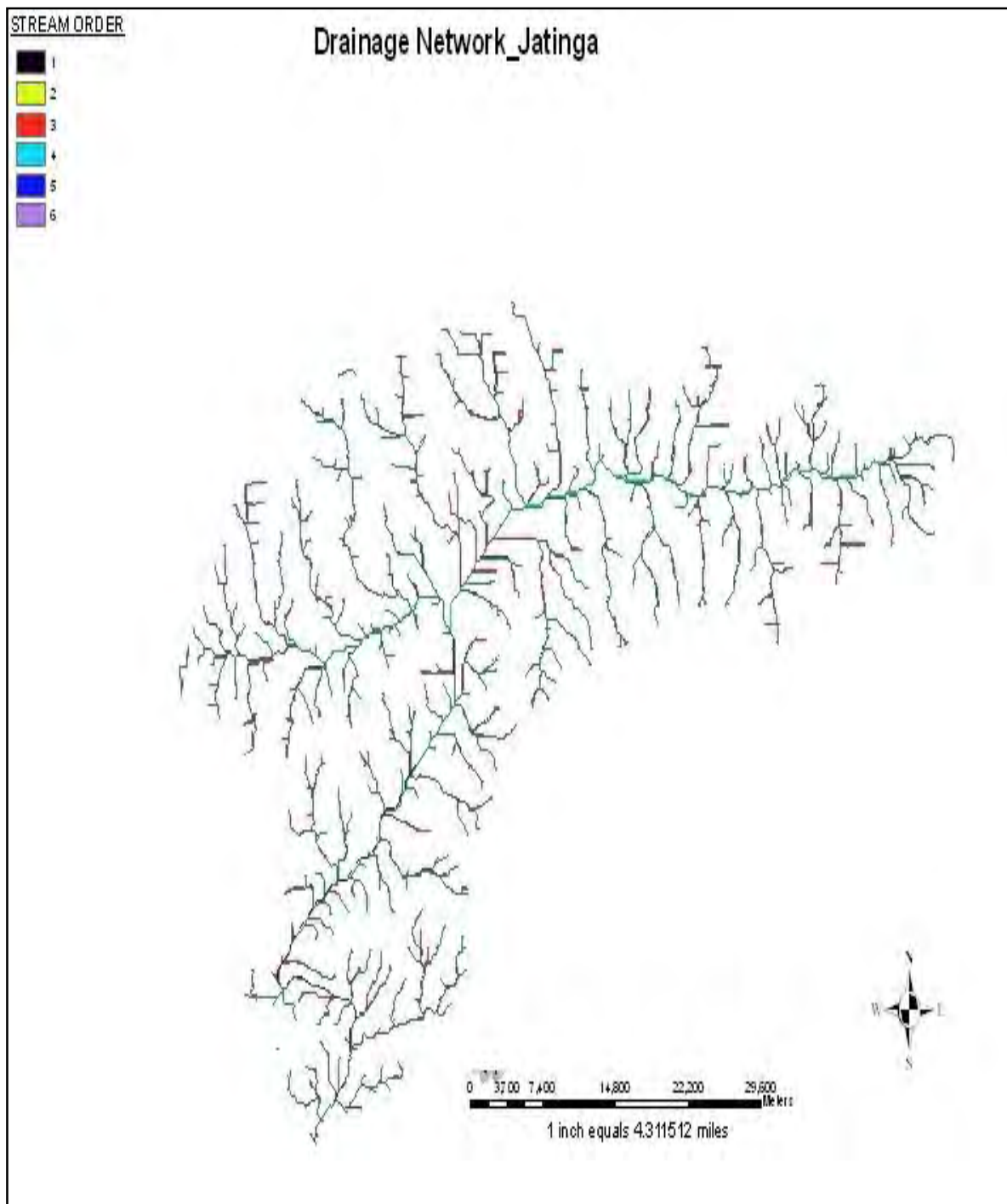

FIGURE 4.11 Drainage network in Jatinga sub catchment

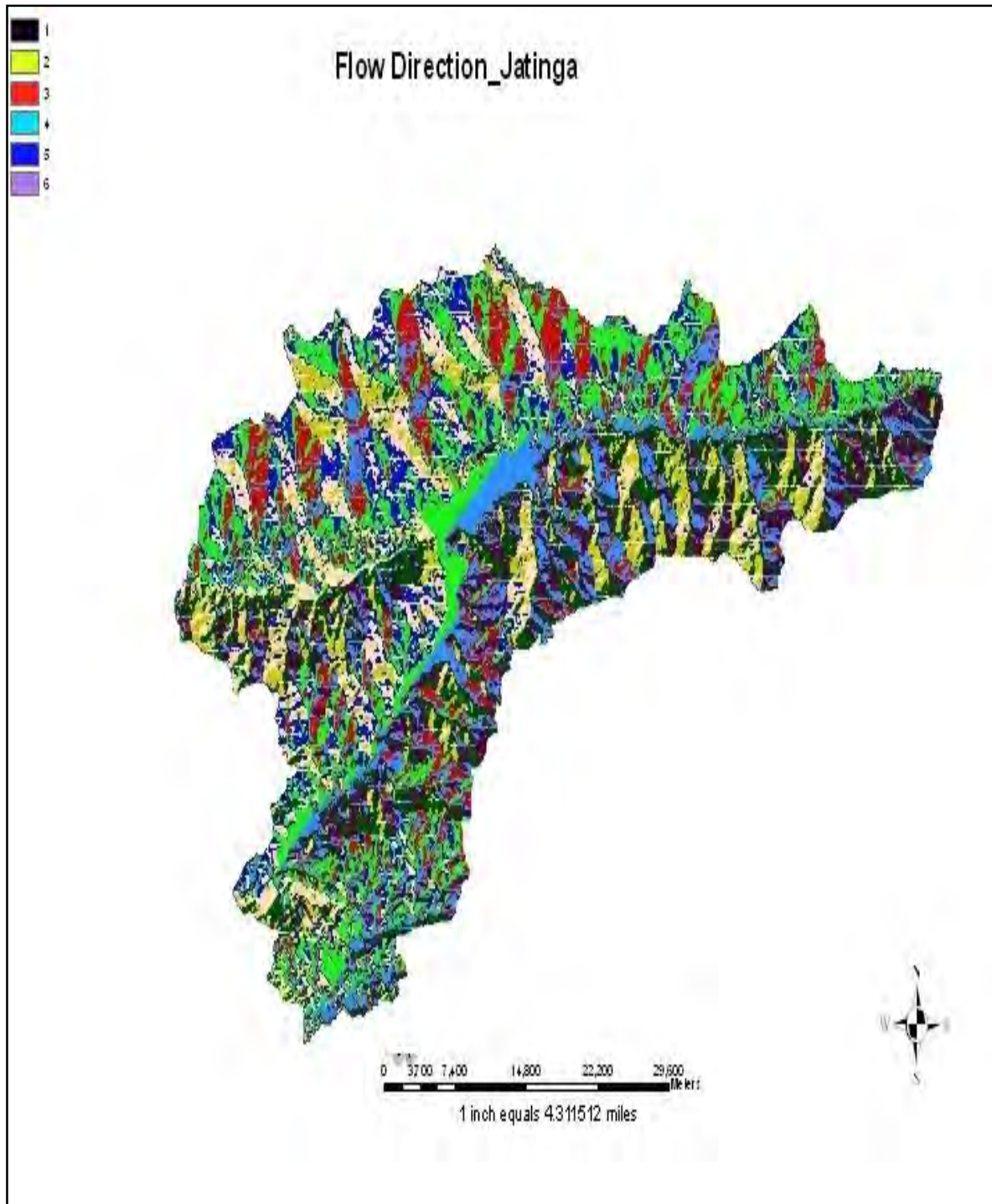

FIGURE 4.12 Flow direction in Jatinga sub catchment



FIGURE 4.13 Drainage network in Katakhal sub catchment

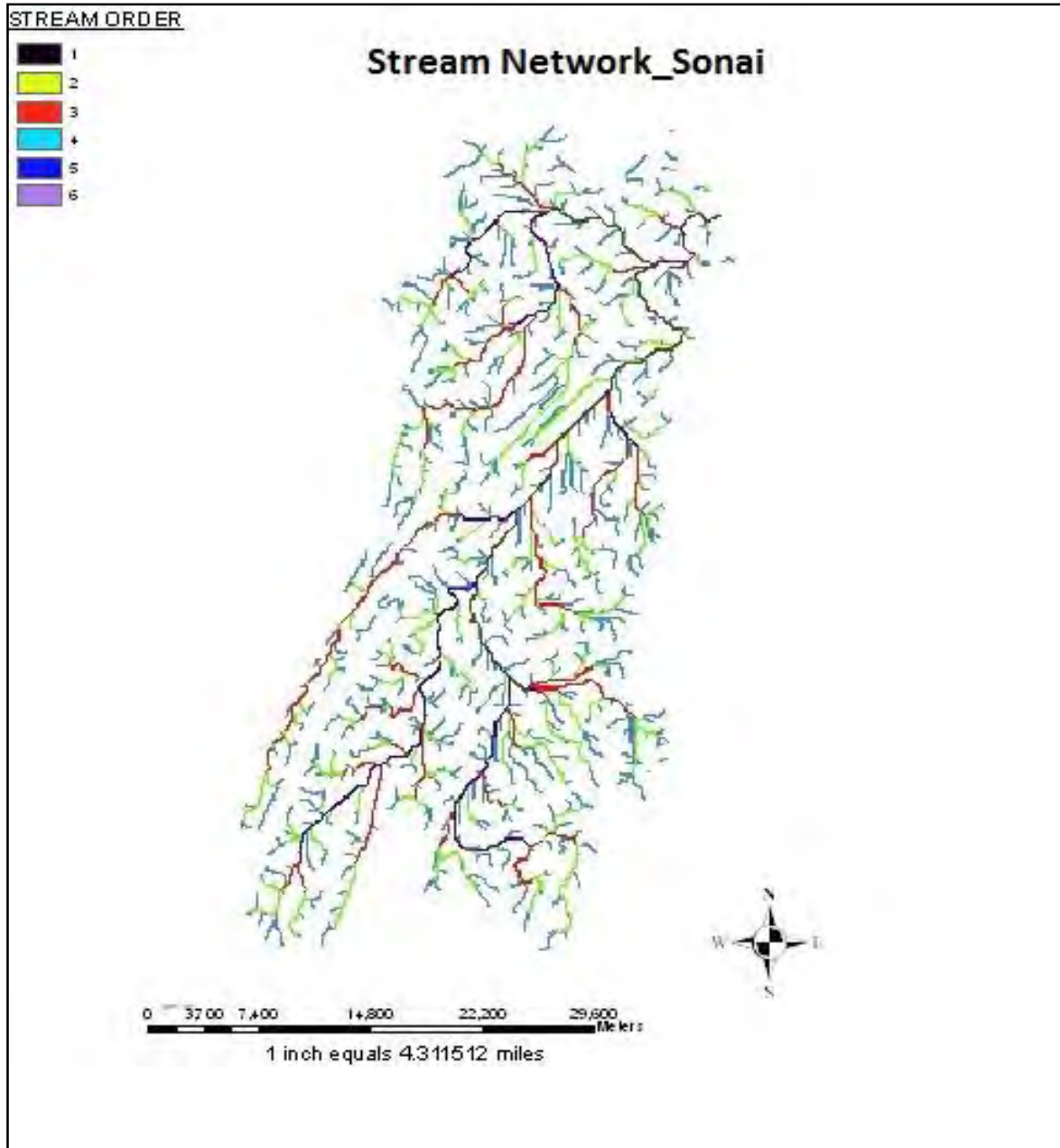

FIGURE 4.14 Drainage network in Sonai sub catchment

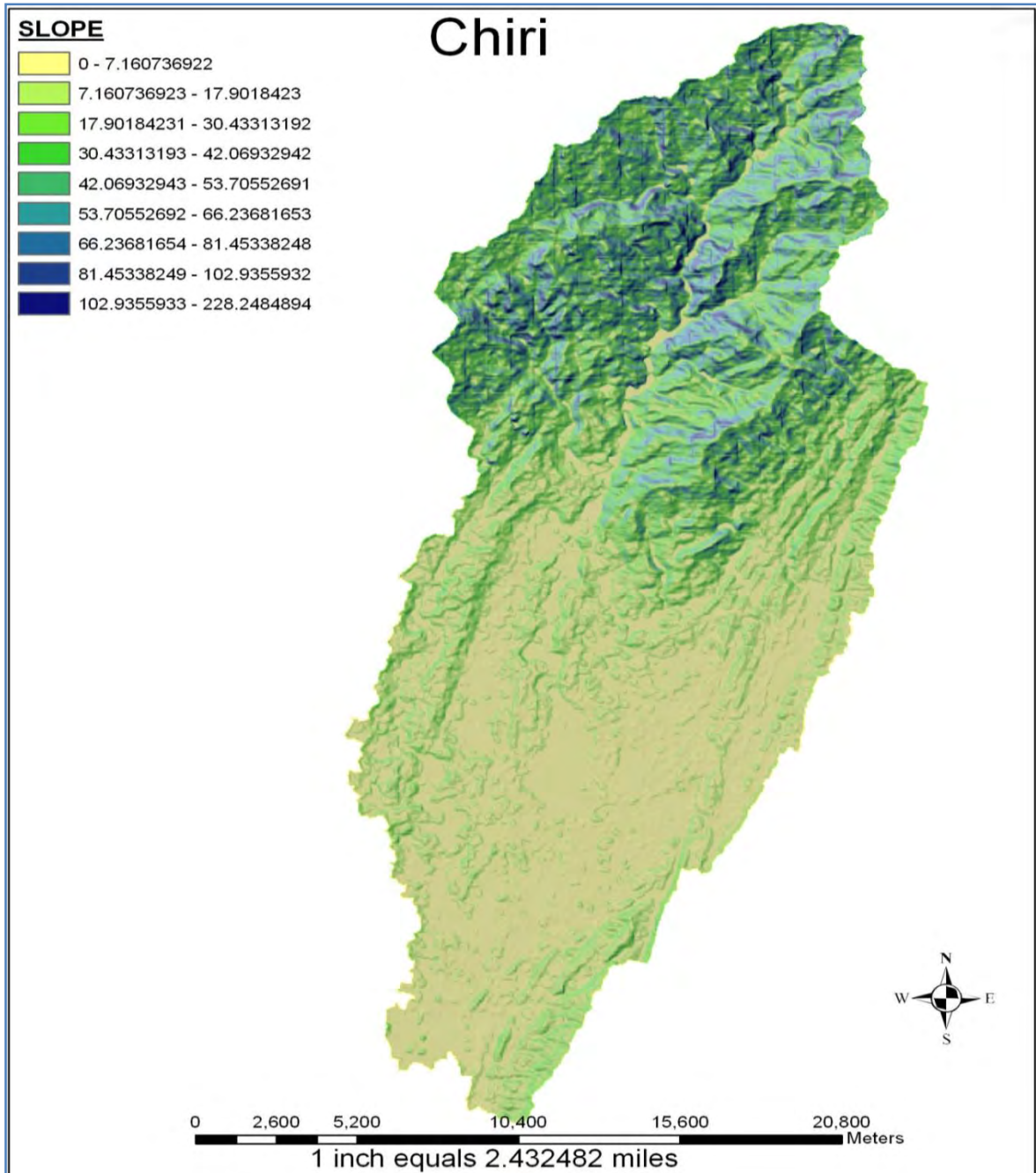

FIGURE 4.15 Slope map for Chiri sub catchment

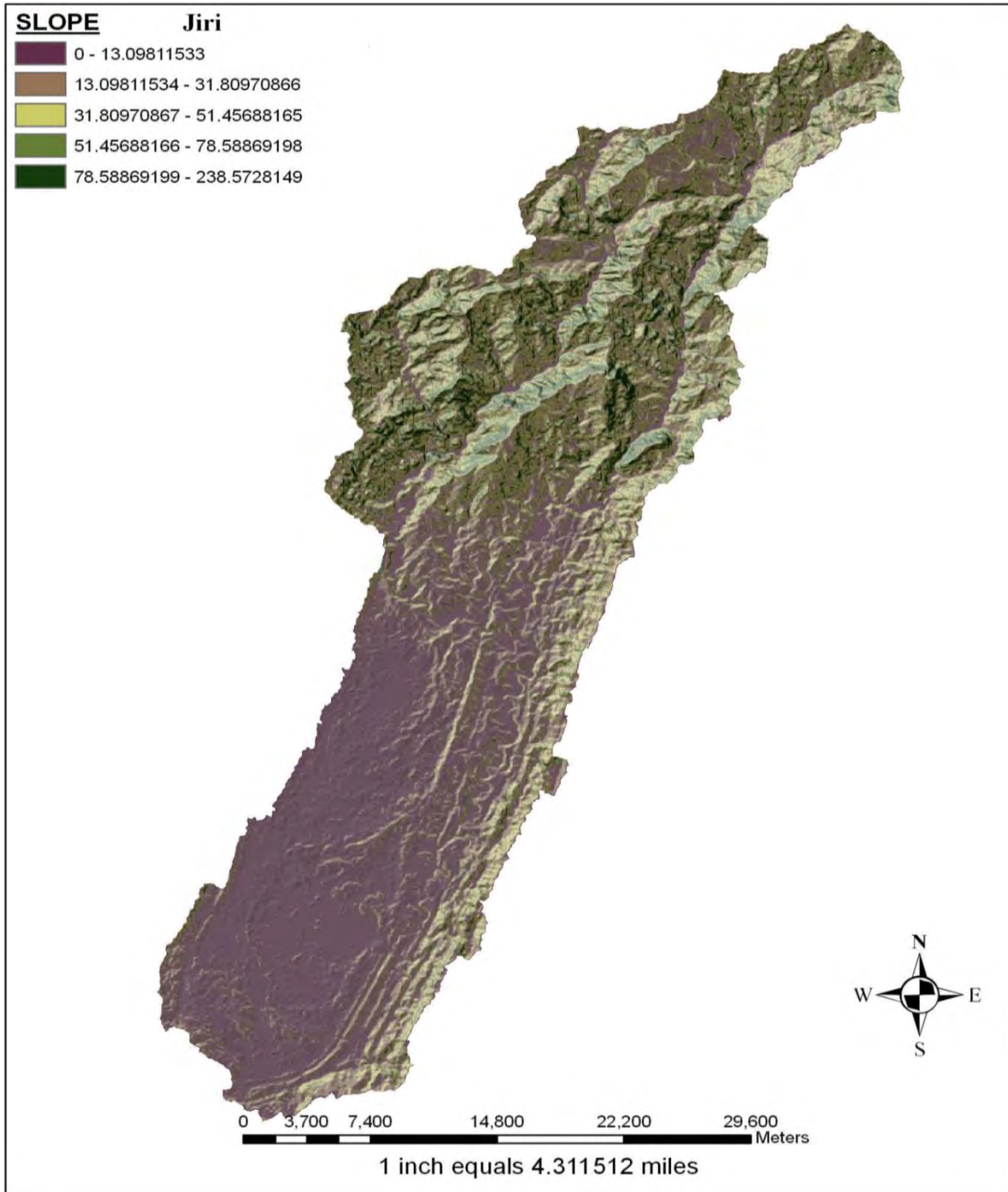

FIGURE 4.16 Slope map for Jiri sub catchment

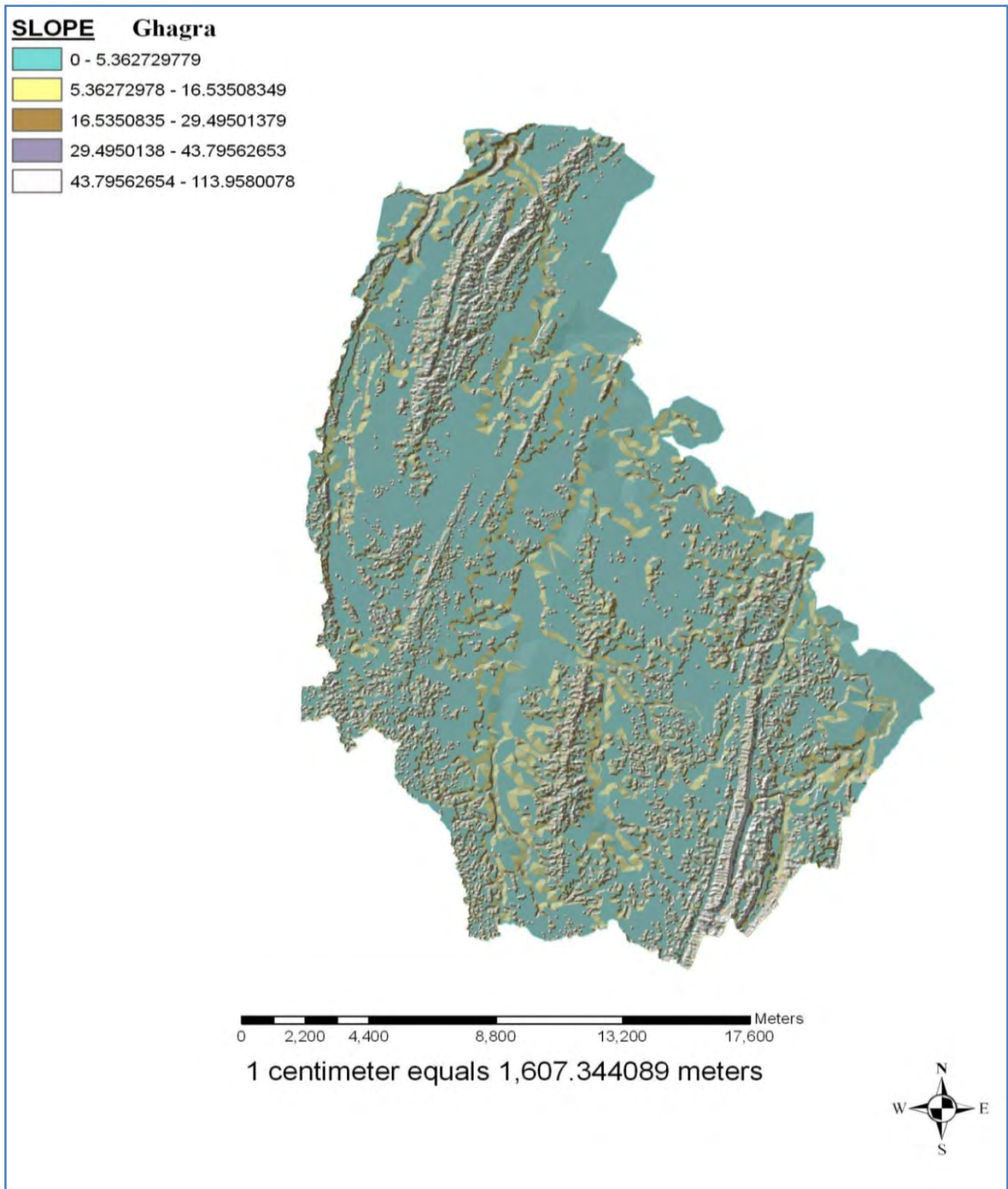

FIGURE 4.17 Slope map for Ghagra sub catchment

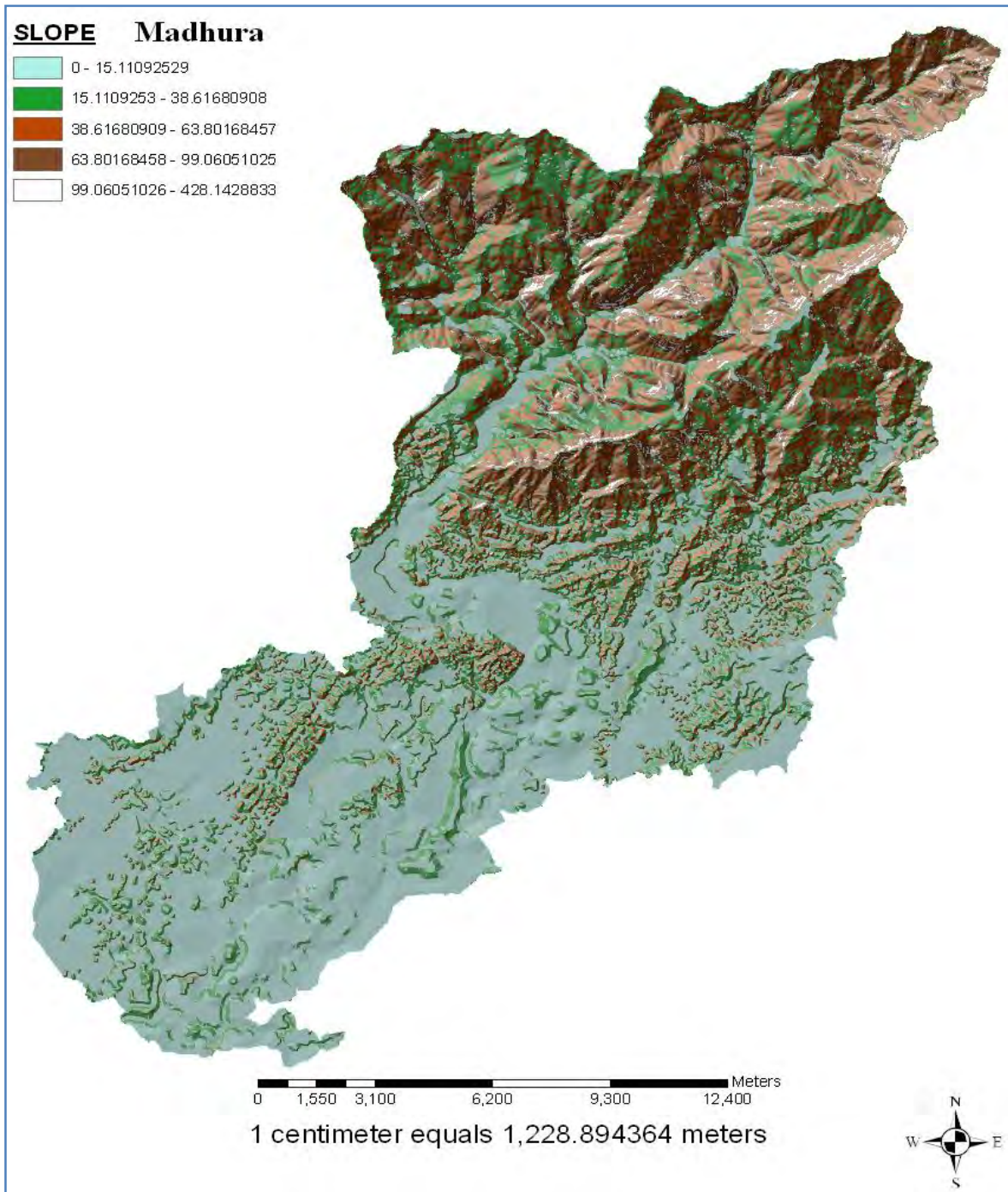

FIGURE 4.18 Slope map for Madhura sub catchment

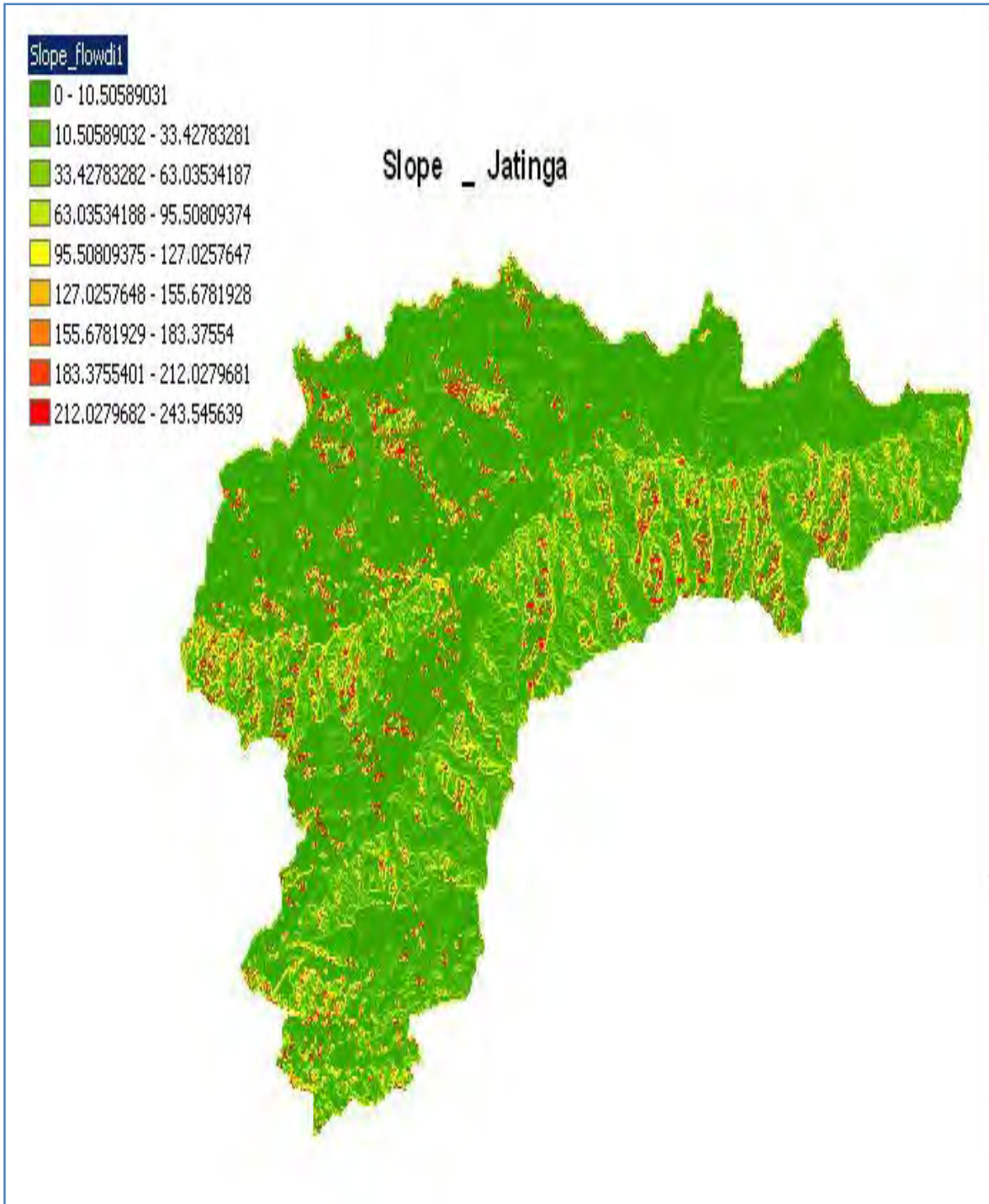

FIGURE 4.19 Slope map for Jatinga sub catchment

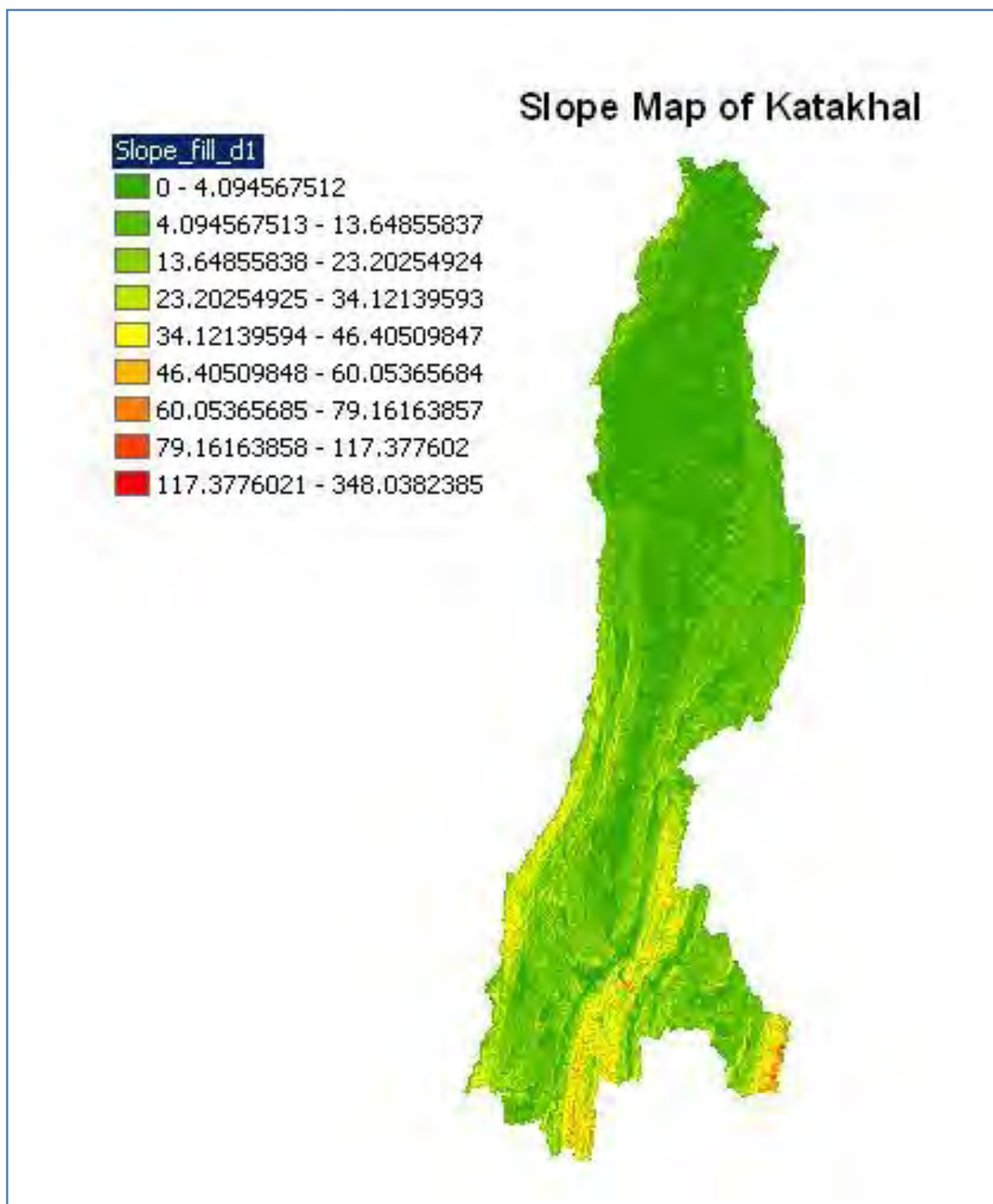

FIGURE 4.20 Slope map for Katakhal sub catchment

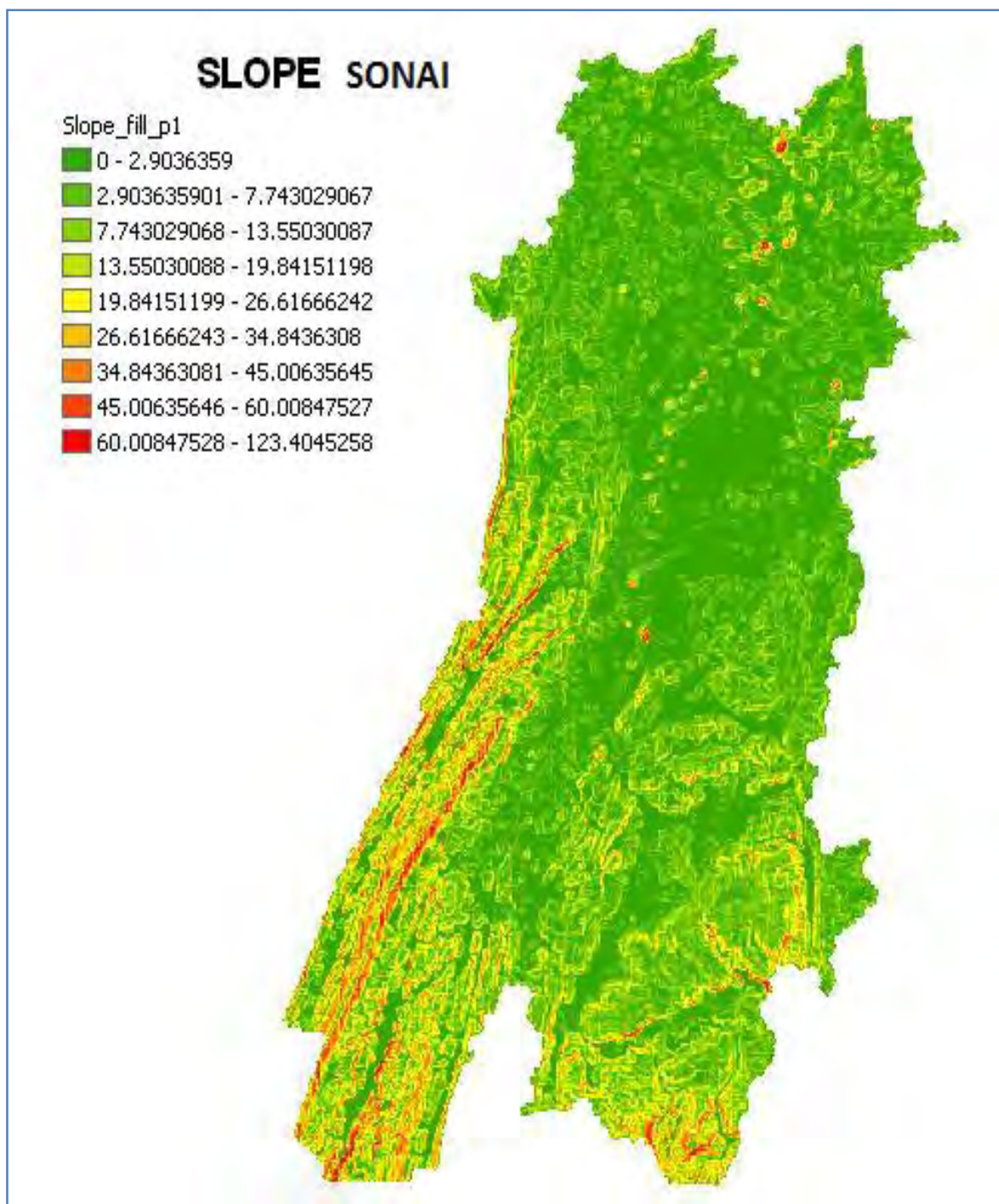

FIGURE 4.21 Slope map for Sonai sub catchment

TABLE 4.1 Watershed and Drainage Characteristics of Sub basins in the Study Area

Watersheds	Drainage Characteristics	Stream Order						Watershed Area (km^2)	Average Slope (%)	Main stream length (km)	Watershed perimeter (km)
		1	2	3	4	5	6				
<i>Madhura</i>	<i>Total Count</i>	781	177	42	10	3	1	349.43	0.28	52.61	170.85
	<i>Average stream length (km)</i>	0.422	0.94	2.072	4.769	12.88	14.59				
<i>Ghagra</i>	<i>Total Count</i>	506	131	33	7	2	1	409.39	0.09	48.93	157.84
	<i>Average stream length (km)</i>	0.659	1.04	2.487	5.907	9.803	19.784				
<i>Jiri</i>	<i>Total Count</i>	1083	277	56	9	3	1	1052.85	0.22	49.85	152.63
	<i>Average stream length (km)</i>	0.635	1.37	2.429	11.69	14.86	48.09				
<i>Chiri</i>	<i>Total Count</i>	569	124	26	8	2	1	438.66	0.26	104.48	275.0
	<i>Average stream length (km)</i>	0.59	1.46	3.39	4.36	19.80	11.62				
<i>Katakhal</i>	<i>Total Count</i>	1183	282	68	19	4	1	1504.6801	10.64%	129.88	401.00
	<i>Average stream length (km)</i>	0.65	1.45	2.12	10.8	13.62	57.43				
<i>Jatinga</i>	<i>Total Count</i>	417	100	25	2	1		371.86	35.085%	55.39	156.00
	<i>Average stream length (km)</i>	0.55	1.03	2.10	4.32	22.93					
<i>Sonai</i>	<i>Total Count</i>	614	169	37	08	02	01	488.249	7.798%	95.212	203
	<i>Average stream length (km)</i>	0.60	1.36	3.21	4.11	11.05	15.976				

5.0 Hydrological Modeling: Development of Unit Hydrographs

Hydrologic responses of a watershed are influenced by geomorphologic characteristics of the watershed. Characterization and quantification of such characteristics is useful and essential in the process of evaluating the hydrologic response of a watershed. These characteristics relate to the physical characteristics of the drainage basin and drainage network; physical characteristics of the drainage basin include drainage area, basin shape, ground slope, and centroid (i.e. centre of gravity of the basin). Channel characteristics include channel order, channel length, channel slope, channel profile, and drainage density. Handling and modeling of such spatially varying parameters have become more efficient and accurate with the emergence of advance computing techniques, Geographic Information System (GIS). For deriving UH using GIUH models different watershed characteristics such as stream length, watershed area, slope, etc are essential. Using topographic maps/SRTM/ASTER data and remote sensing data in GIS software like ArcGIS, ERDAS imagine, ILWISS, etc Digital Elevation Model (DEM) can be developed and analyzed. With DEM as an input to quantify the watershed characteristics slope map, stream map, etc may be obtained. Watershed characteristics for the sub basins in the study area that were estimated by using GIS supported techniques is given in table-4.1. DEM, Stream networks and the slope maps for the watersheds in the study area are also presented in the earlier sections. Using DEM flow direction and flow accumulation maps for the watersheds are developed. With the **drainage network map as input and using Strahler's stream ordering law the drainage network for the watersheds are ordered applying GIS stream ordering tool. On the basis of the ordered drainage network, areas drained and stream lengths for different stream orders are obtained. Horton's geomorphologic parameters (Horton, 1945) R_A , R_B and R_L for the watershed are estimated graphically by plotting average areas drained, stream numbers and average stream length respectively against the stream orders. Absolute slope value for the best fit line is taken to compute the ratios. Graphical representations showing best fit line is used for computing R_A , R_B and R_L for the watersheds. The best fit lines for Madhura and Ghagra watersheds are shown in Figures. Estimated geomorphologic parameters for all watersheds are given in the Table-4.1. Estimated watersheds mean slope and main stream length values**

are used in equation (5.1) to obtain velocity factor for the watersheds respectively. The velocity parameter estimated for Madhura and Ghagra watersheds are listed in the Table-5.2. The listed parameters are used to develop triangular based 1hr UHs for the watersheds applying GIUH techniques. The GIUH model given by equations (5.1), (5.2) and (5.3) are used to estimate peak discharge, time to peak and time base of the IUH for the watersheds in the study area.

$$V = 0.8562L^{0.23}S^{0.385} \quad (5.1)$$

$$q_p = 1.31R_L^{0.43}(V/L_\Omega) \quad (5.2)$$

$$t_p = 0.44(L_\Omega/V)(R_B/R_A)^{0.55}(R_L)^{-0.38} \quad (5.3)$$

$$t_b = 2/q_p \quad (5.4)$$

Here, q_p peak flow in units of inverse hours (h^{-1}); t_p time to peak in hours (h); V dynamic parameter velocity (m/s); L_Ω length of the highest order stream in the watershed (km); and R_L, R_B and R_A = Horton's length ratio, bifurcation ratio and area ratio respectively. To develop IUH for the watersheds dynamic parameter velocity estimated for the watersheds and listed in Tables are used in equations (5.2) and (5.3) obtaining q_p, t_p and t_b values for the watersheds. To develop UH for the watersheds the subbasins are segmented into a number subwatersheds and IUH for these subwatersheds are computed applying GIUH technique. The sub water IUHs are lagged to develop 1-hr UH for the sub watersheds. The UHs routed to the main watershed outlet using kinematic wave technique and superimposed obtaining IUH for the main watershed. Detailed description of unit hydrograph computation for two watersheds, Madhura and Ghagra watersheds are listed. IUH ordinates for the watersheds at an interval of **0.1h** are computed and lagged applying S-Curve technique to derive 1hr UH for the watersheds. 1-hr UH estimated for the watersheds using GIUH technique are shown in the figures and tables presented in the next pages.

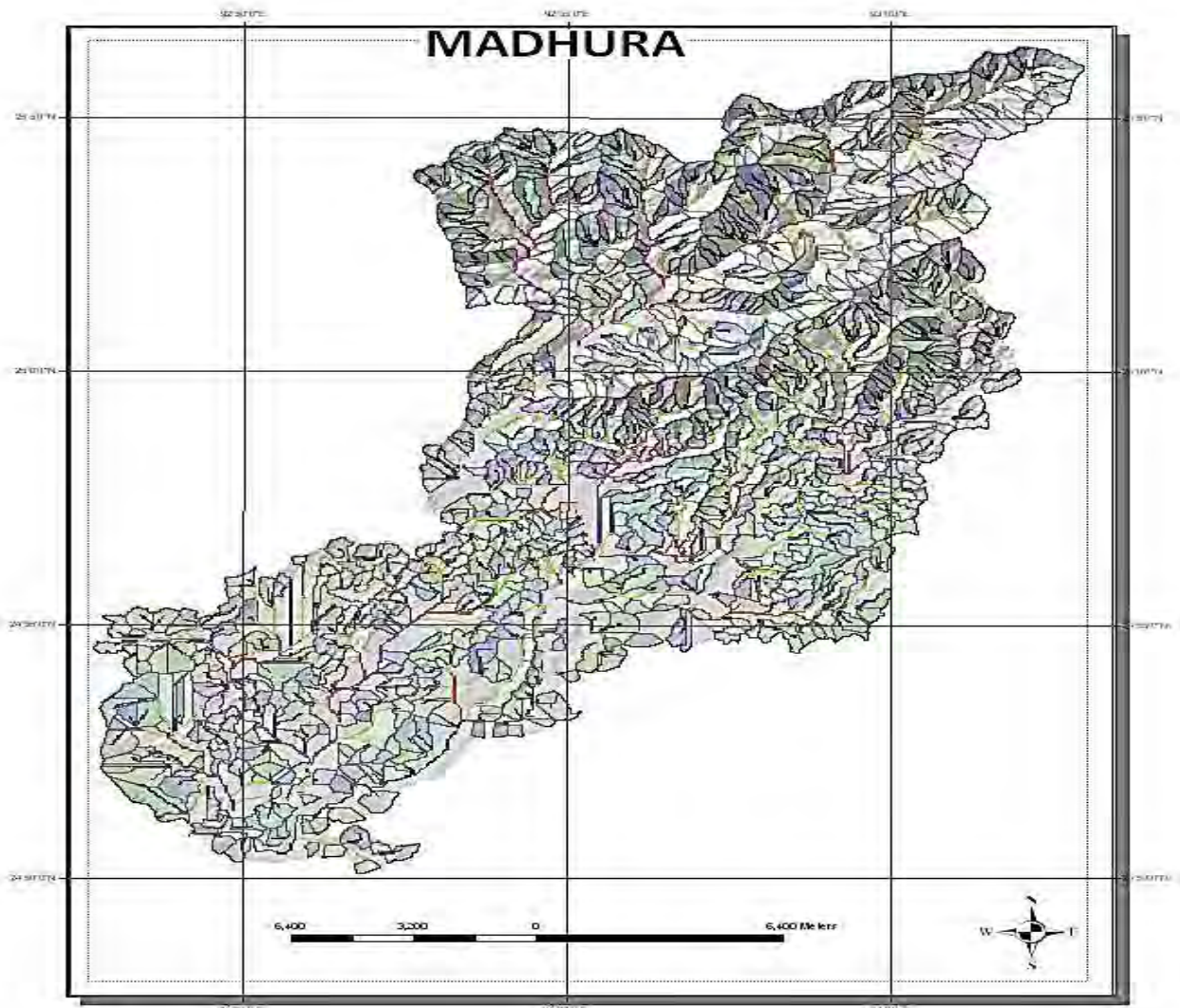

FIGURE 5.1 1st order watersheds for Madhura

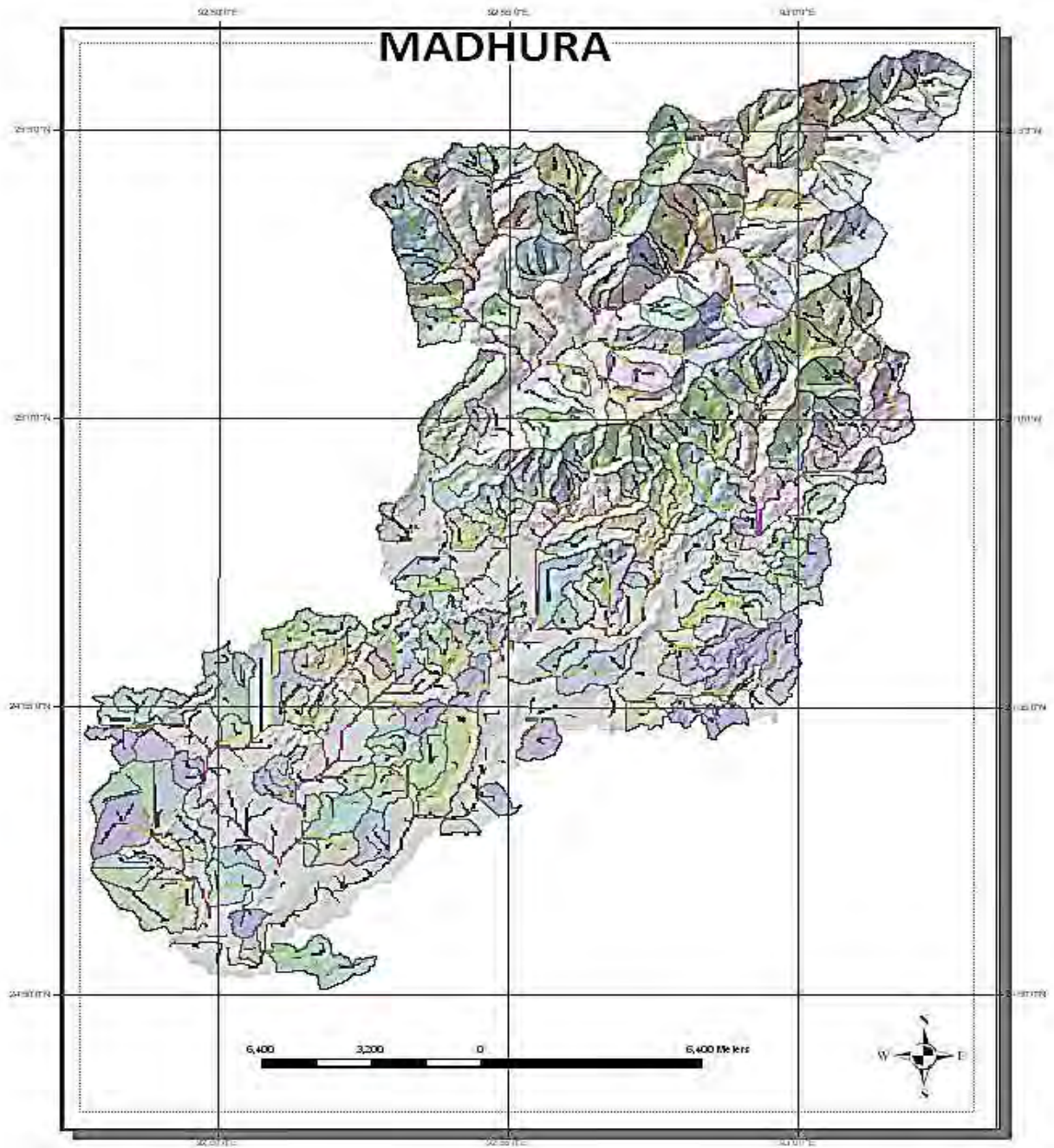

FIGURE 5.2 2nd Order sub-watersheds for Madhura.

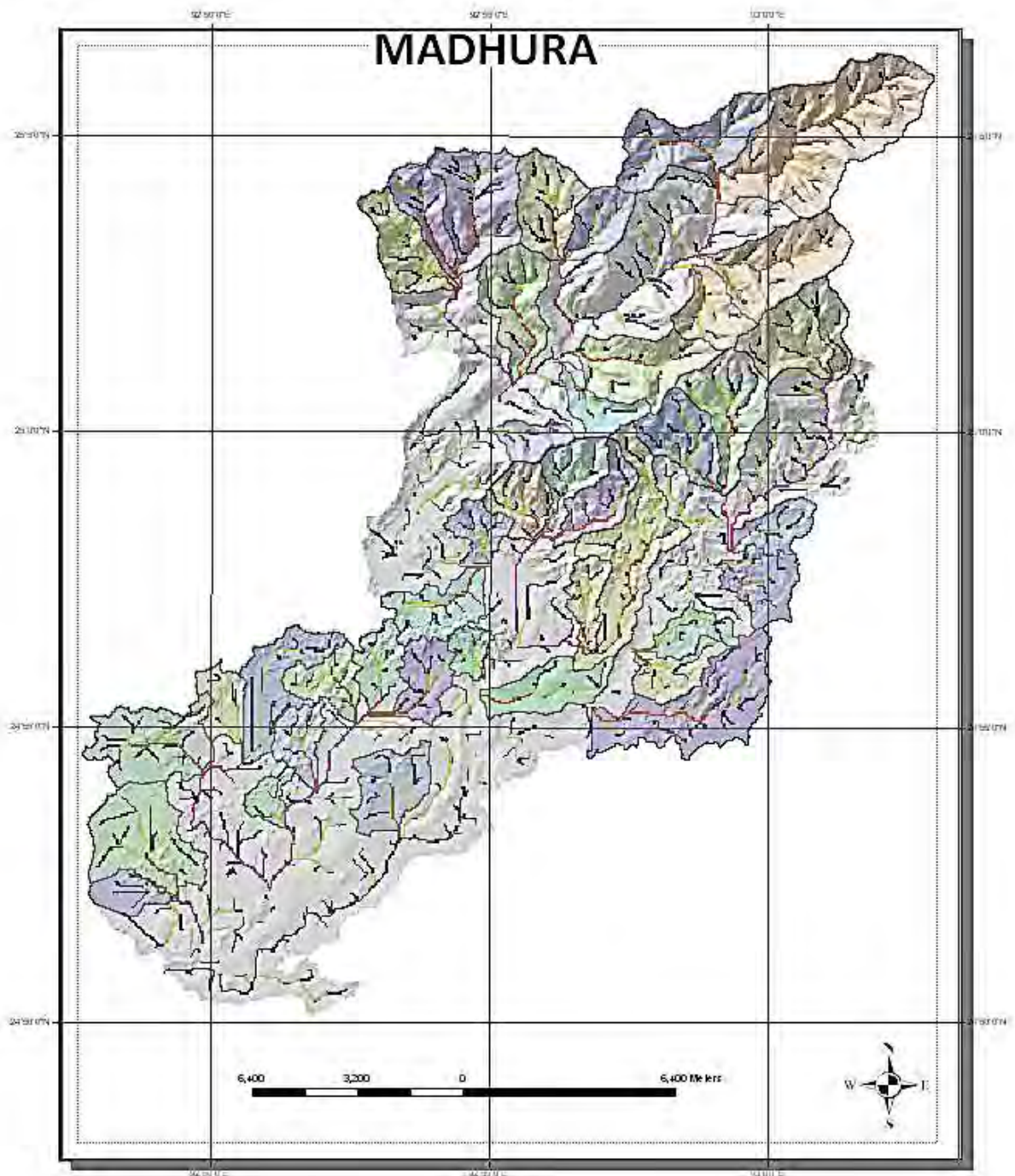

FIGURE 5.3 2nd Order sub-watersheds for Madhura.

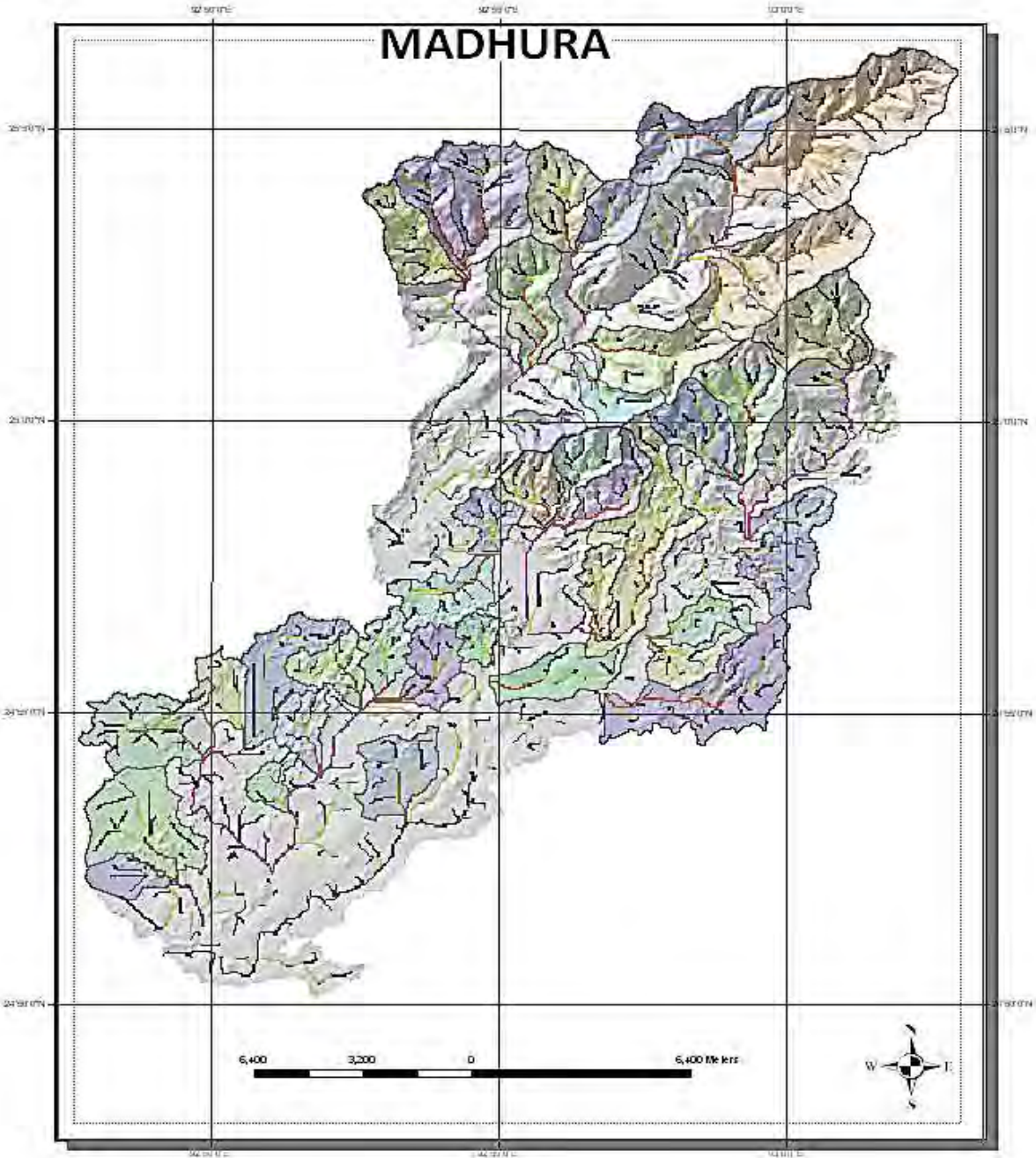

FIGURE 5.4 3rd Order sub-watersheds for Madhura

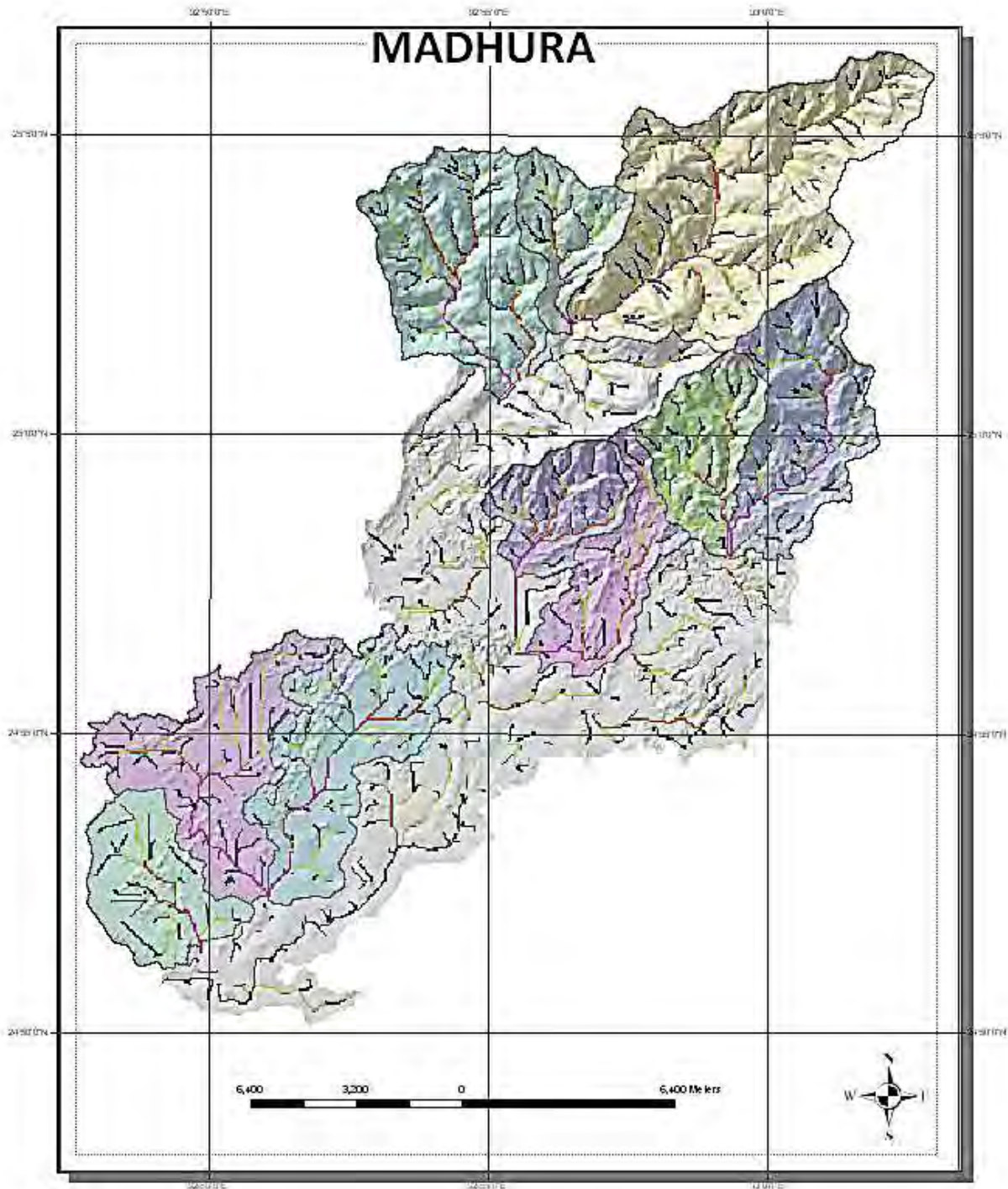

FIGURE 5.5 4th Order sub-watersheds for Madhura.

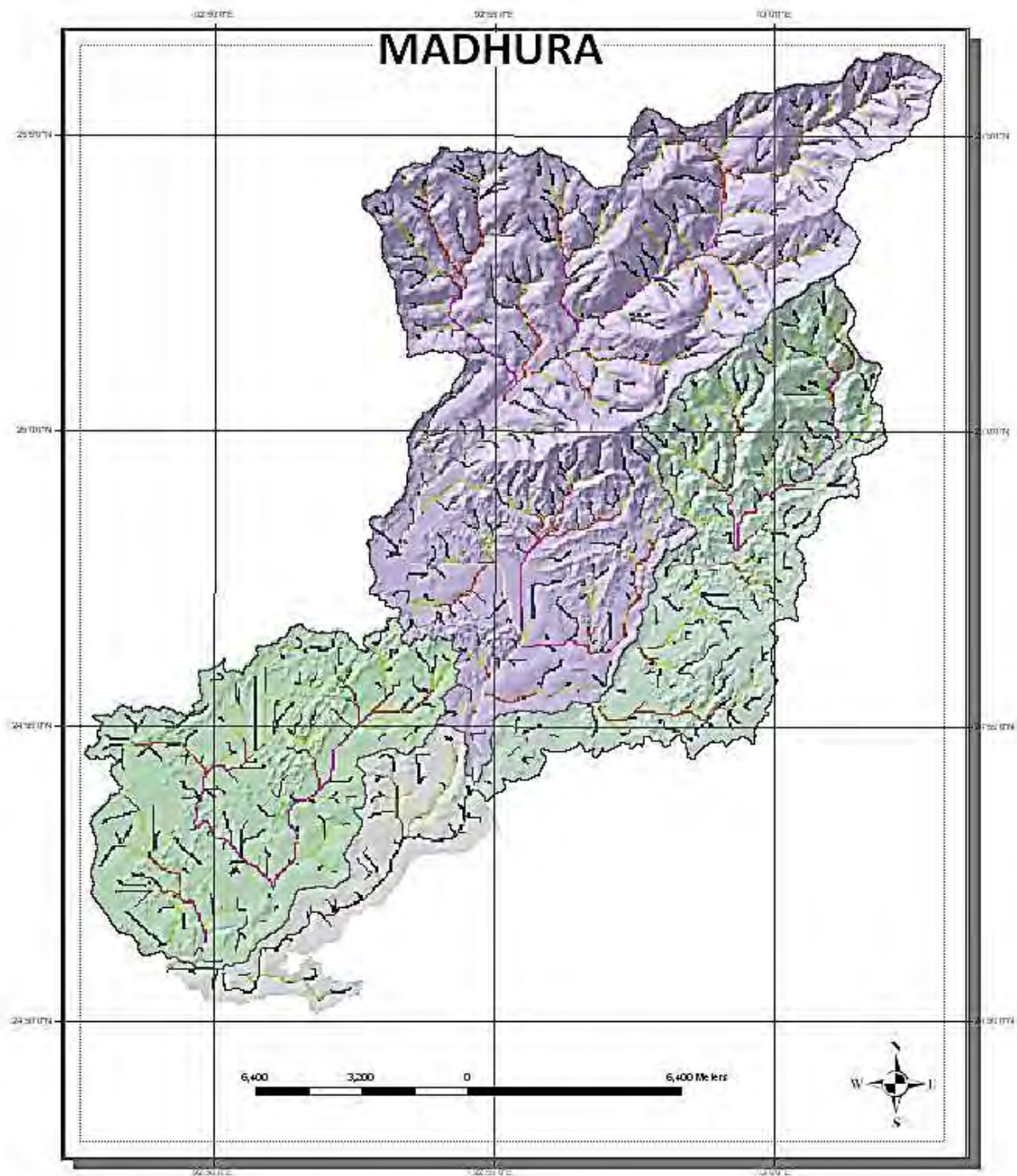

FIGURE 5.6 5th Order sub-watersheds for Madhura.

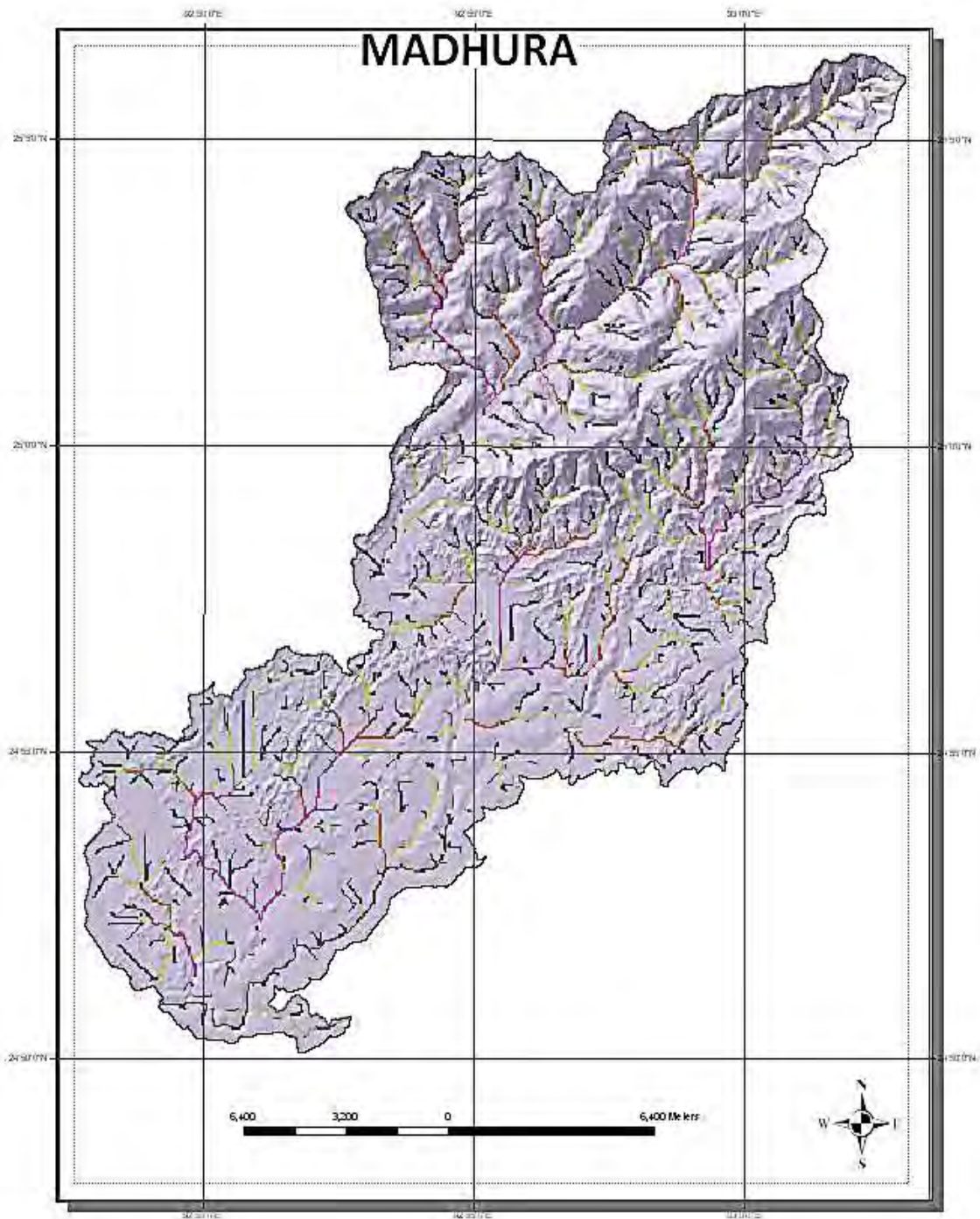

FIGURE 5.7 Madhura watershed (6th Order).

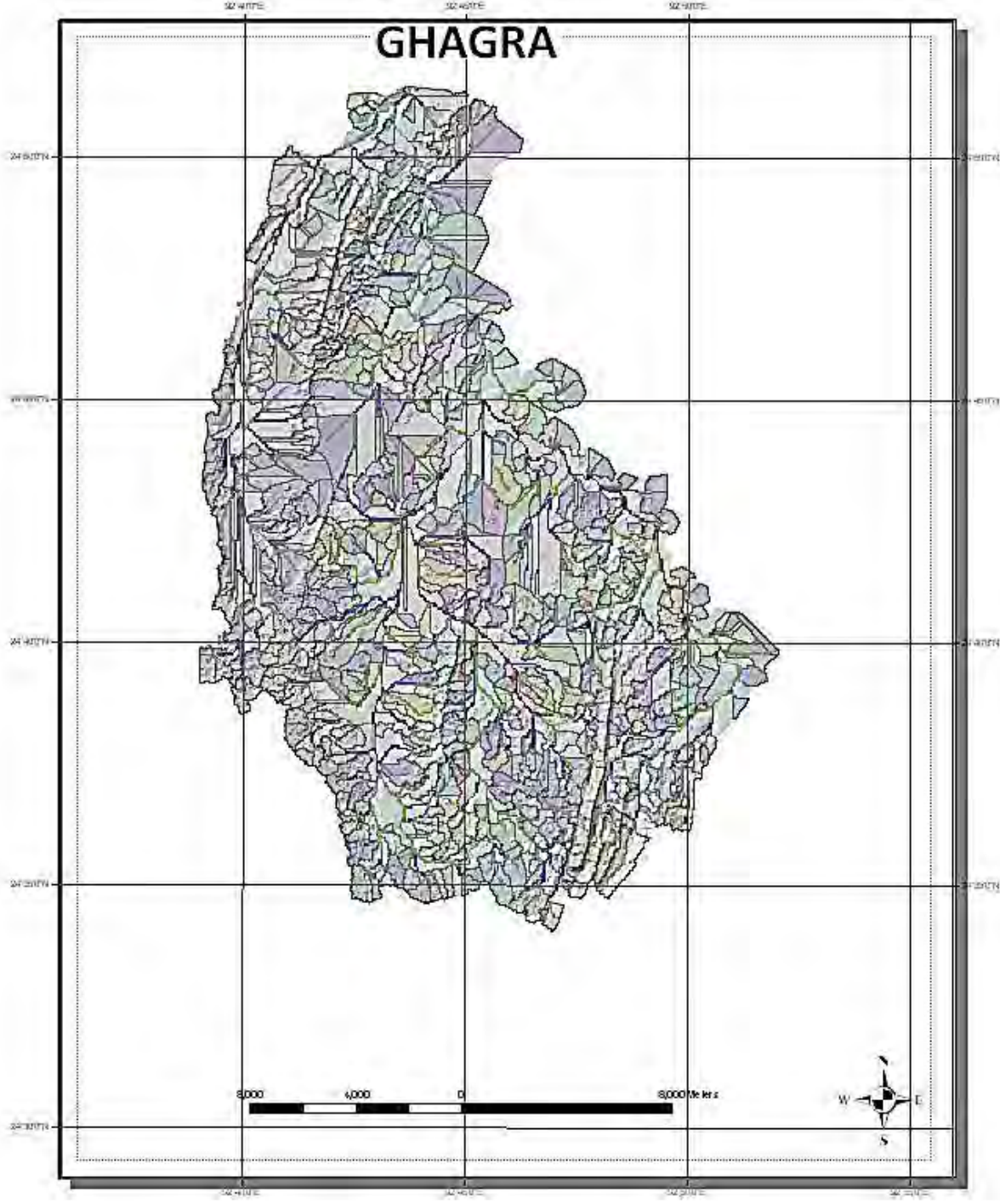

FIGURE 5.8 1st Order sub-watersheds for Ghagra.

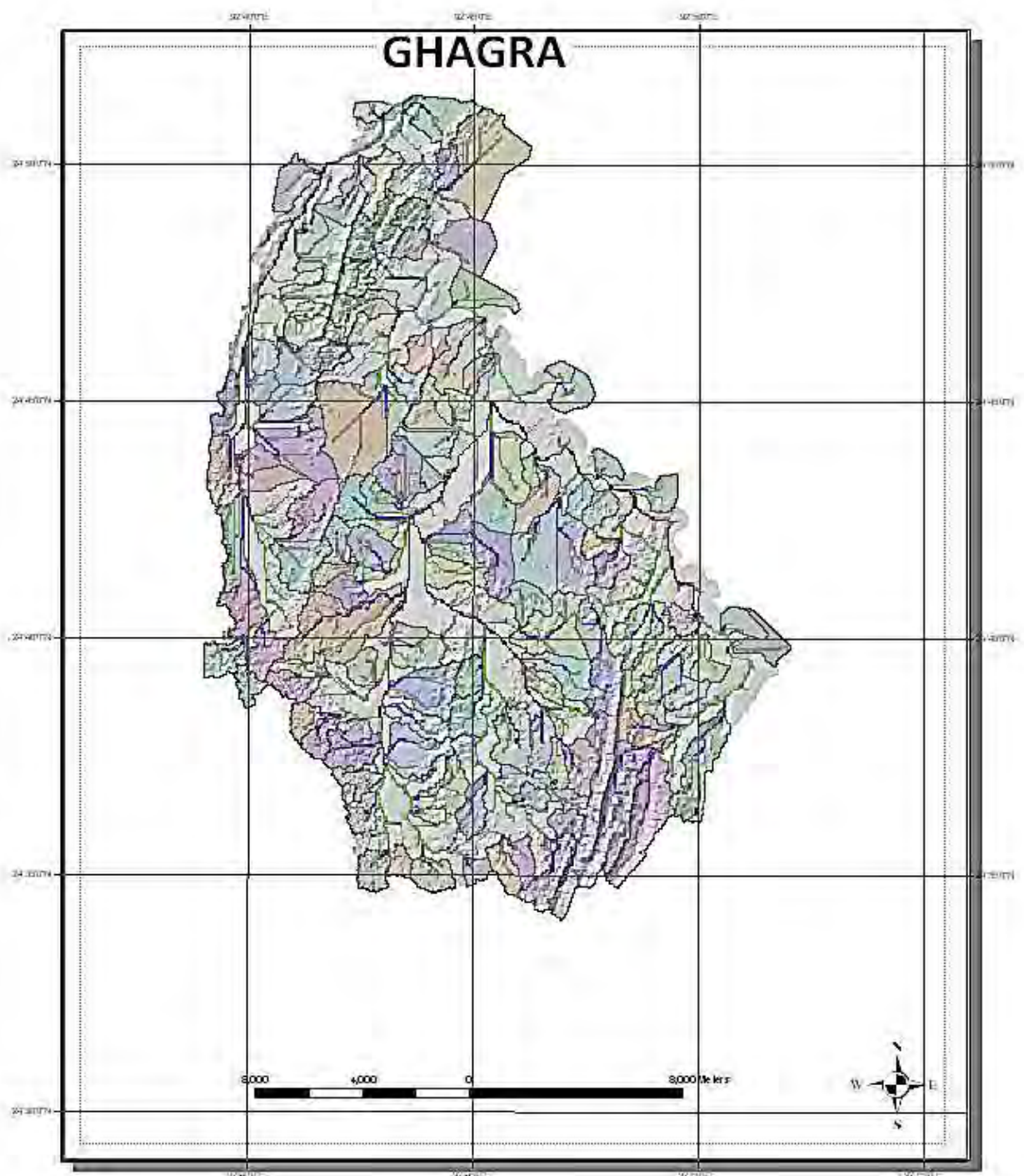

FIGURE 5.9 2nd order sub-watersheds for Ghagra.

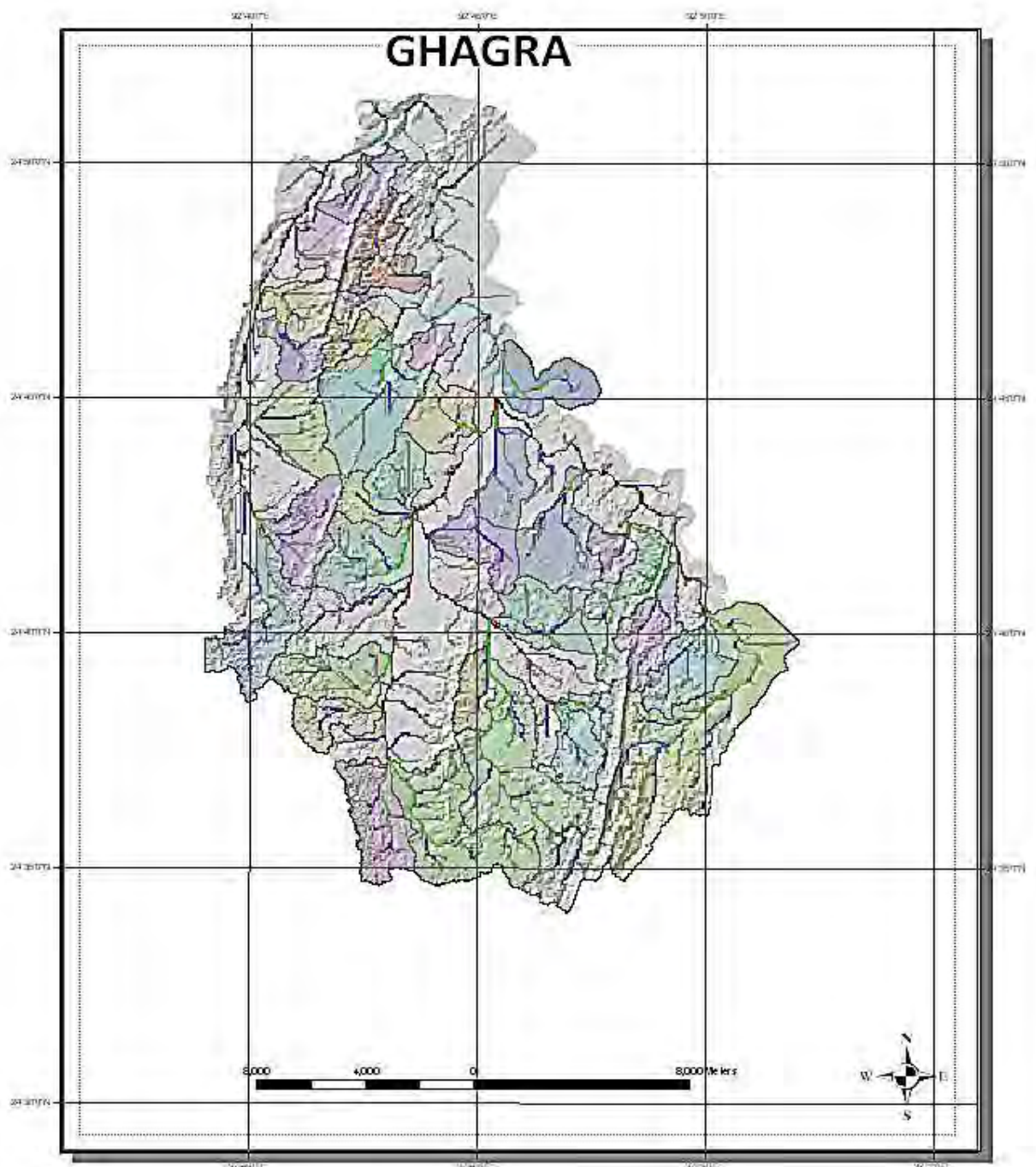

FIGURE 5.10 3rd Order sub-watersheds for Ghagra.

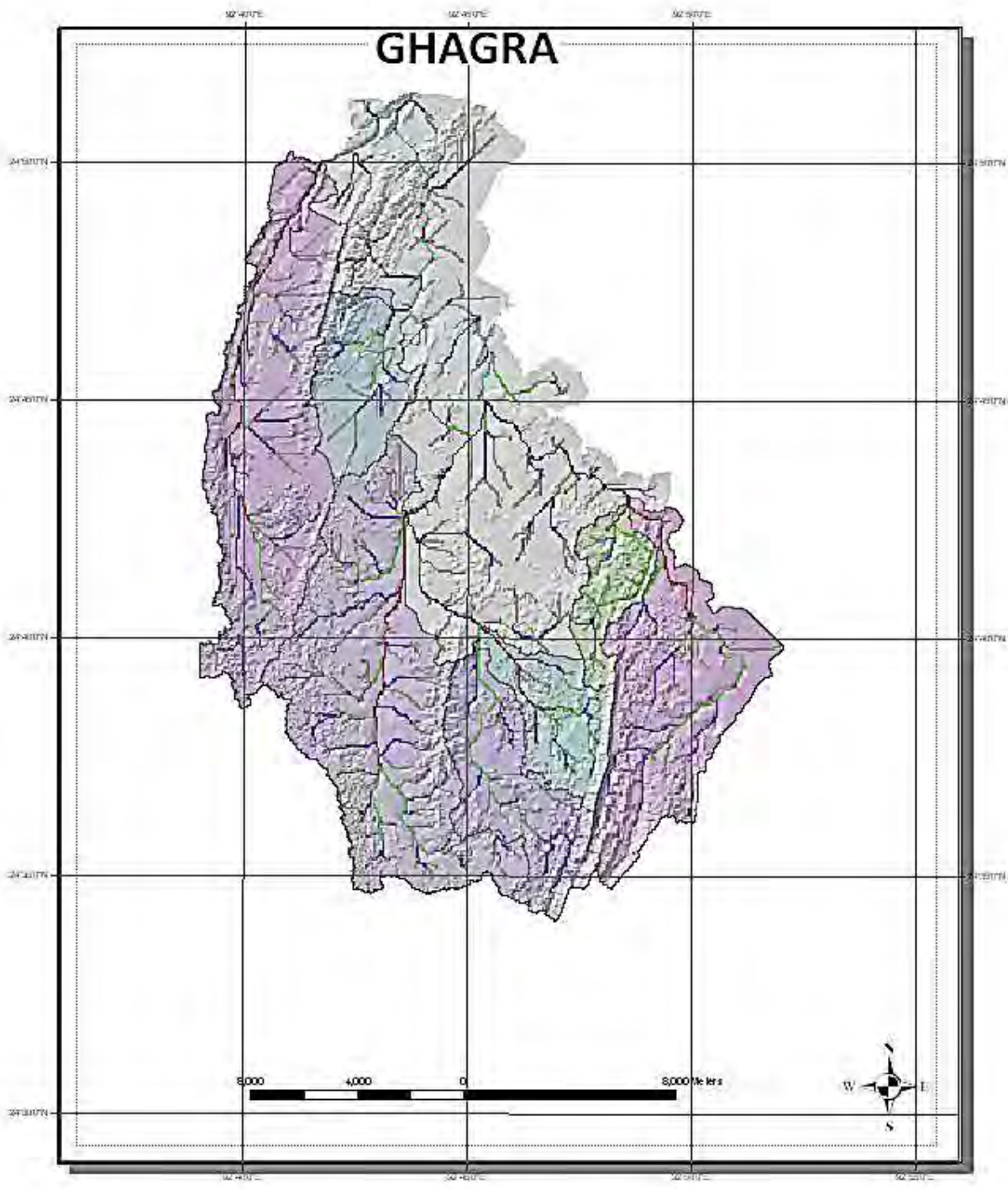

FIGURE 5.1 4th Order sub-watersheds for Ghagra.

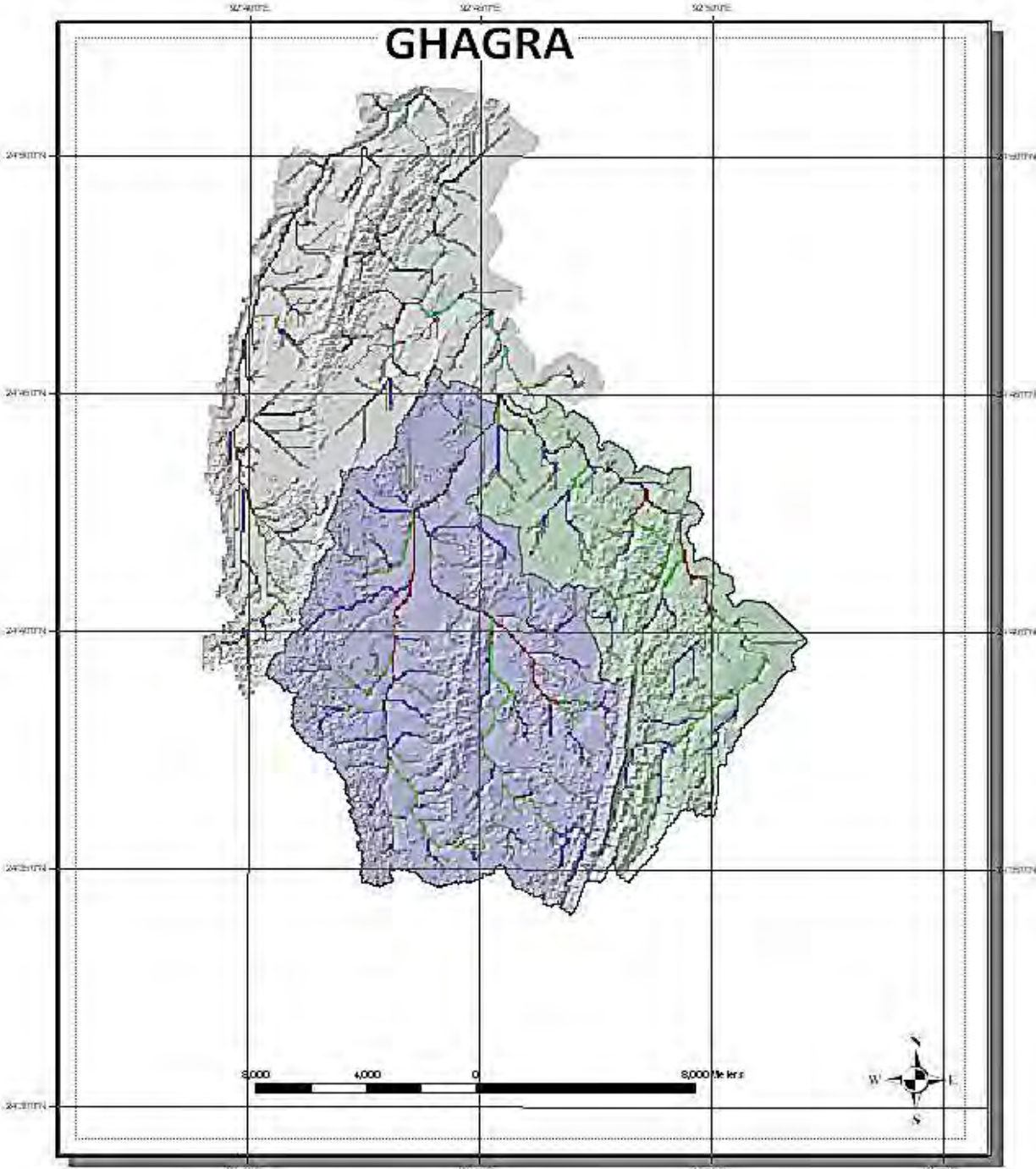

FIGURE 5.12 5th order sub-watersheds for Ghagra.

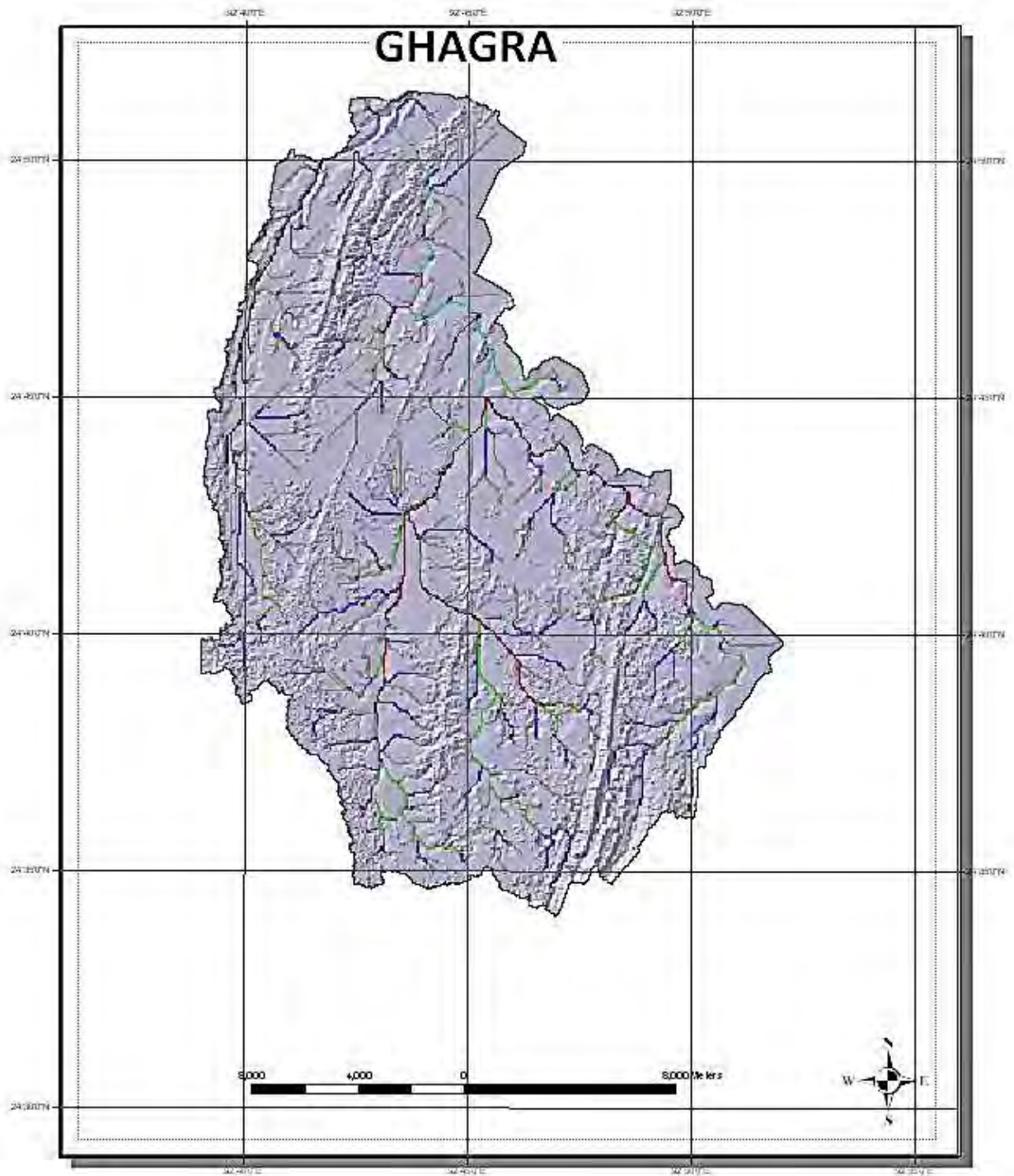

FIGURE 5.13 Ghagra watershed (6th order).

The Subwatersheds selected for Madhura for development of IUH are indicated in the figure given below:

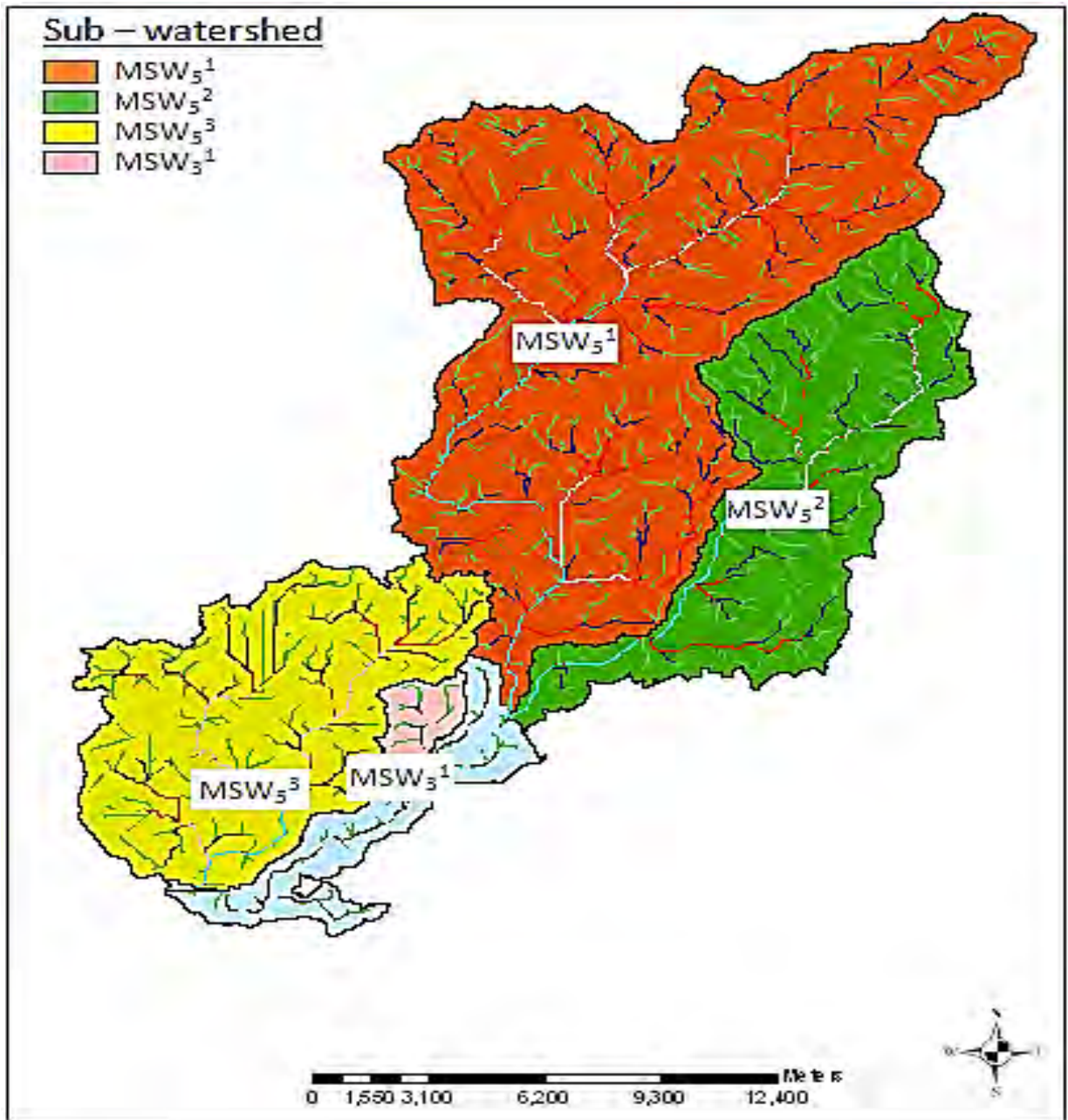

FIGURE 5.14 Selected sub-watersheds for Madhura.

Subwatersheds in Ghagra selected for developing IUH are as given in the figure given below:

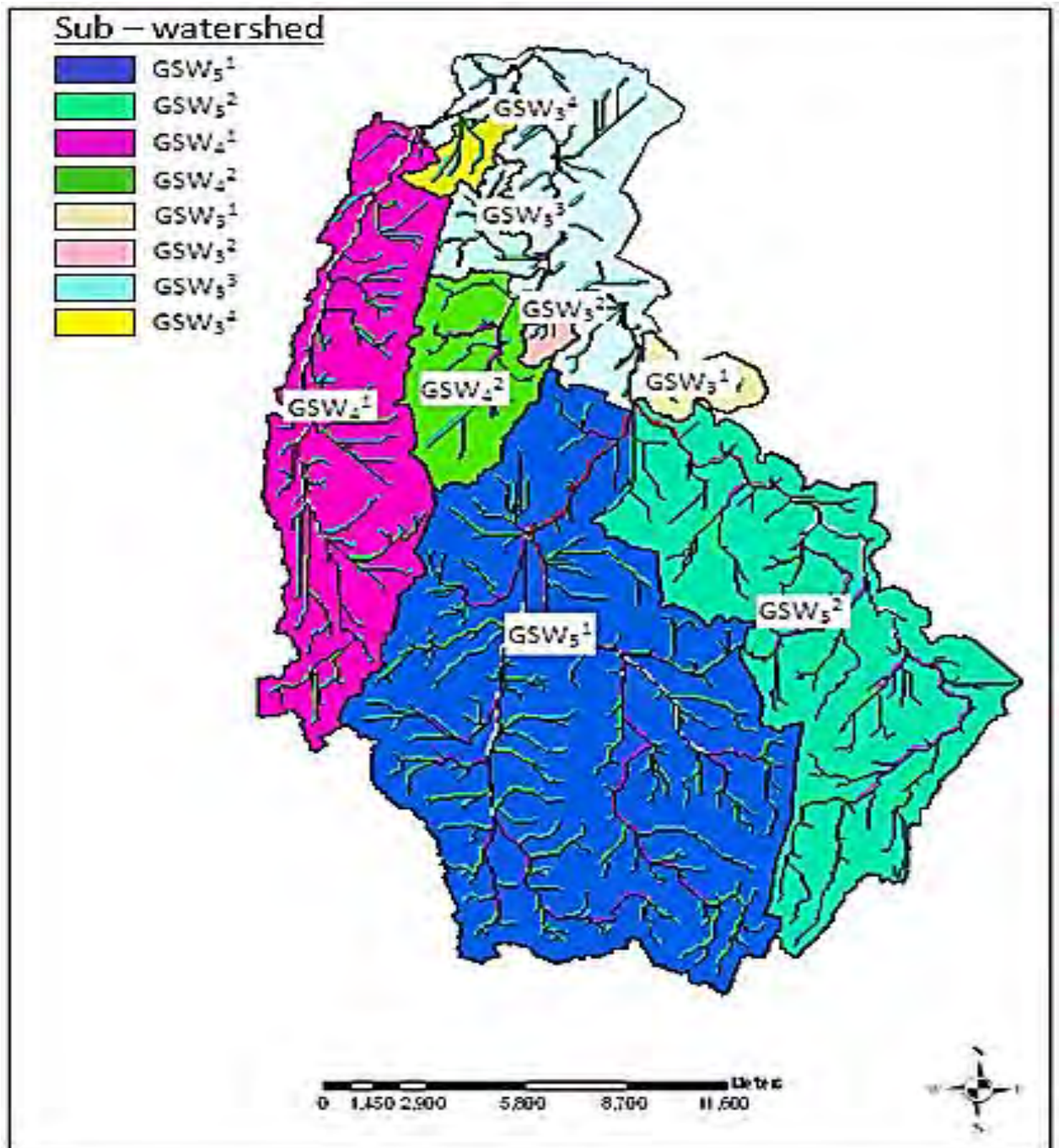

FIGURE 5.15 Selected sub-watersheds for Ghagra.

Applying conversion tool the raster file of ordered stream network, area drained are converted into vector file and extracted in Microsoft Office Excel worksheet. Using the extracted data sub-watersheds average stream length, stream numbers, average area drained by different orders of stream are obtained. Horton's geomorphologic parameters R_A, R_B and R_L for the sub-watersheds are estimated graphically by plotting the estimated average areas drained, stream numbers and average stream length respectively against the stream orders. Absolute slope values for the best fit line are taken to compute the ratios. Graphical representations showing best fit lines used for computing R_A, R_B and R_L for respective sub-watersheds are shown in Figures-516 through 5.27.

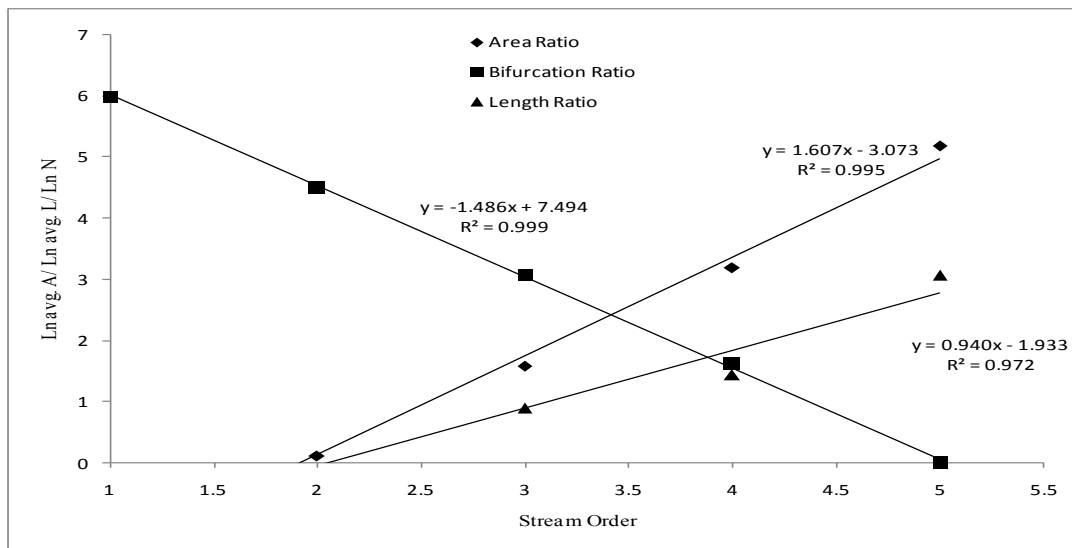

FIGURE 516 Estimation of ratios R_A, R_B and R_L for MSW_5^1 .

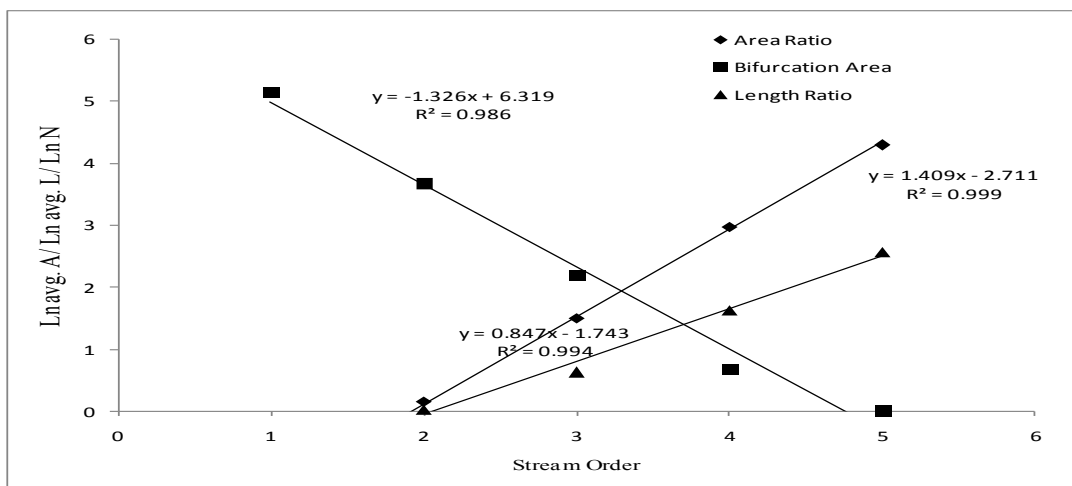

FIGURE 5.17 Estimation of ratios R_A, R_B and R_L for MSW_5^2 .

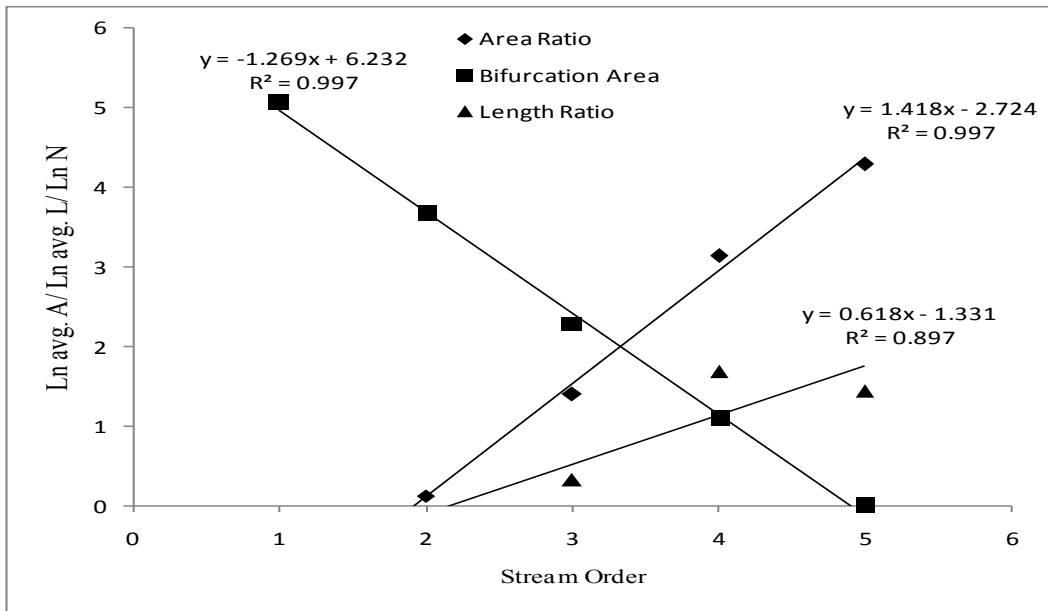

FIGURE 5.18 Estimation of ratios R_A, R_B and R_L for MSW_5^3 .

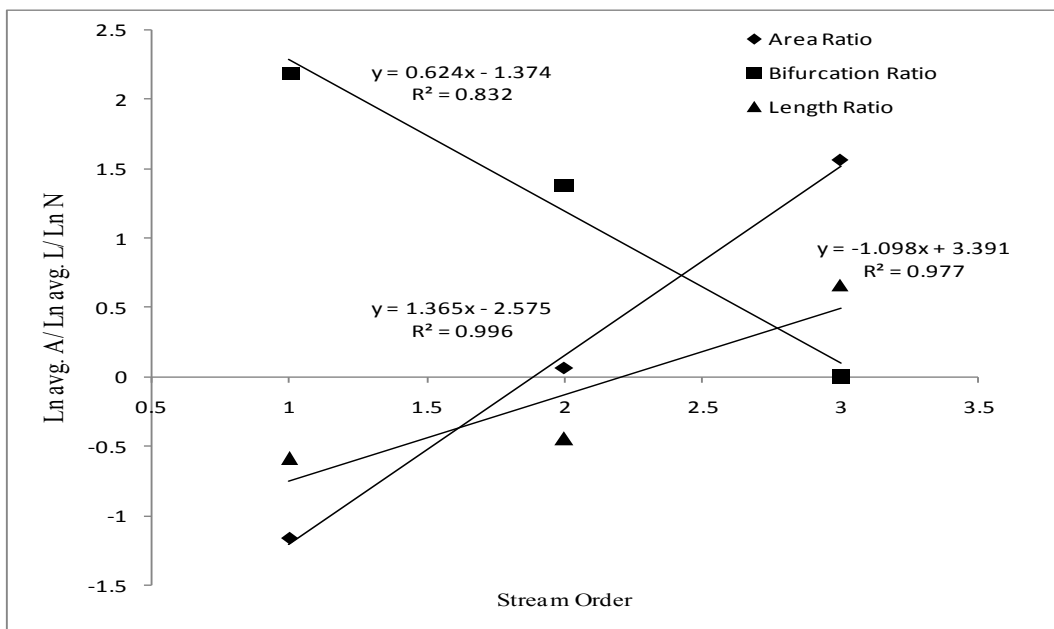

FIGURE 5.19 Estimation of ratios R_A, R_B and R_L for MSW_3^1 .

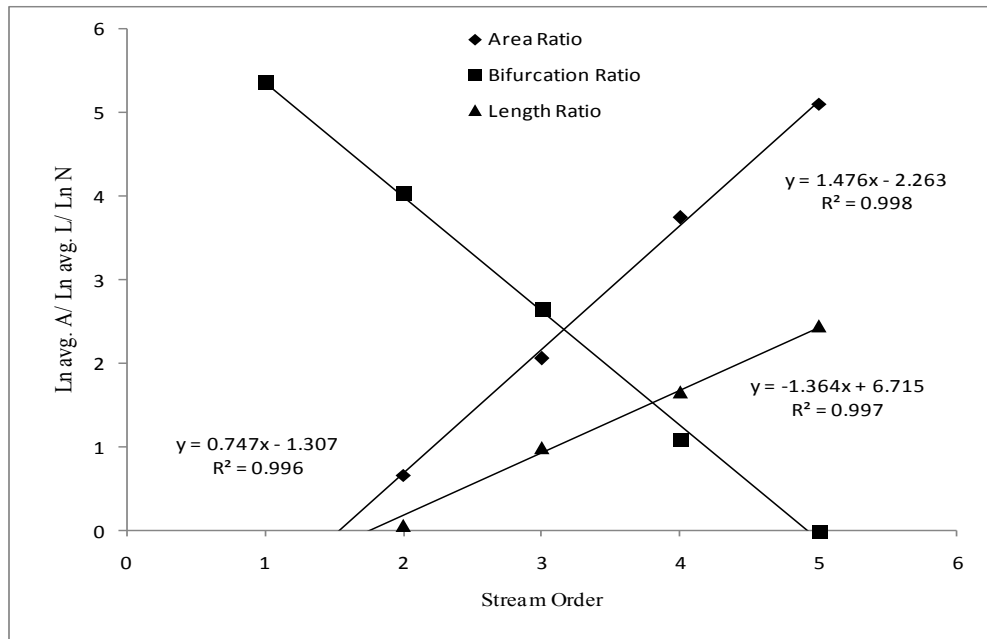

FIGURE 5.20 Estimation of ratios R_A , R_B and R_L for GSW_5^1 .

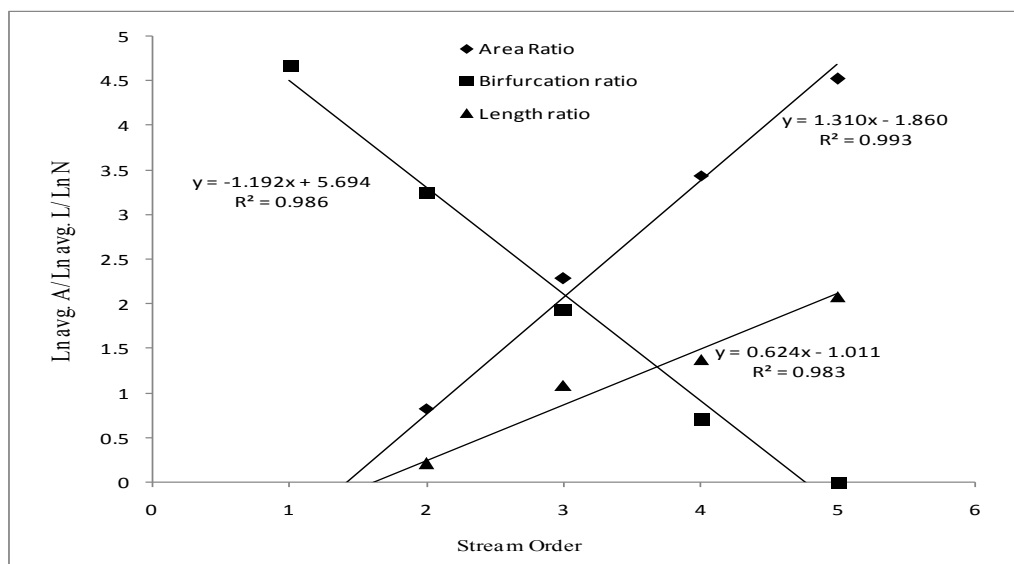

FIGURE 5.21 Estimation of ratios R_A , R_B and R_L for GSW_5^2 .

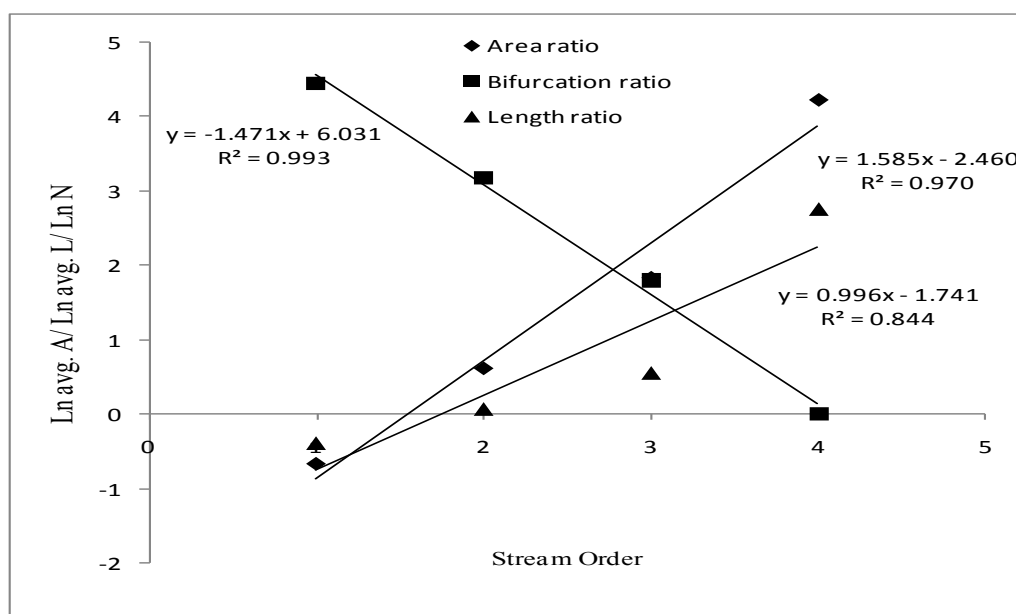

FIGURE 5.22 Estimation of ratios R_A , R_B and R_L for GSW_4^1 .

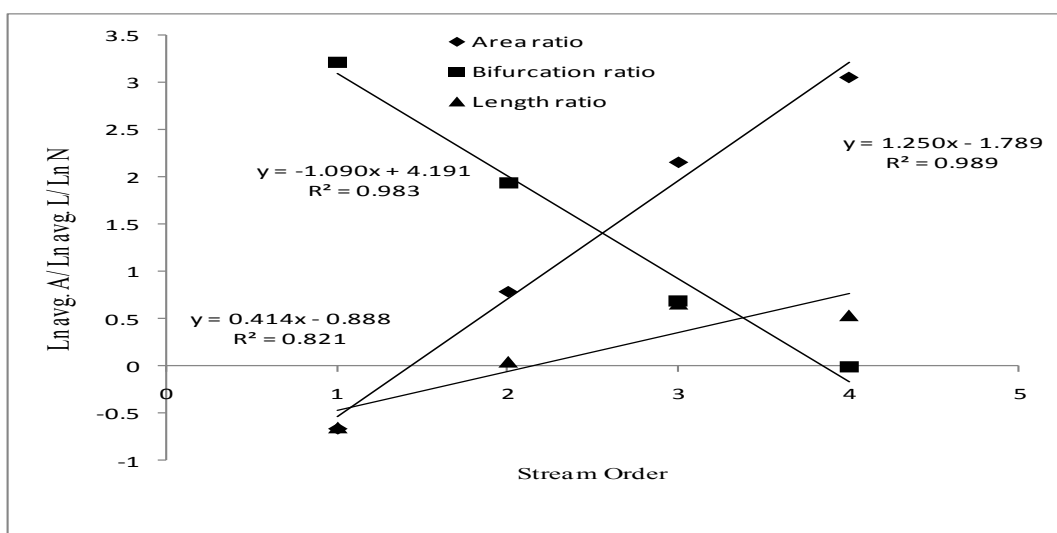

FIGURE 5.23 Estimation of ratios R_A , R_B and R_L for GSW_4^2 .

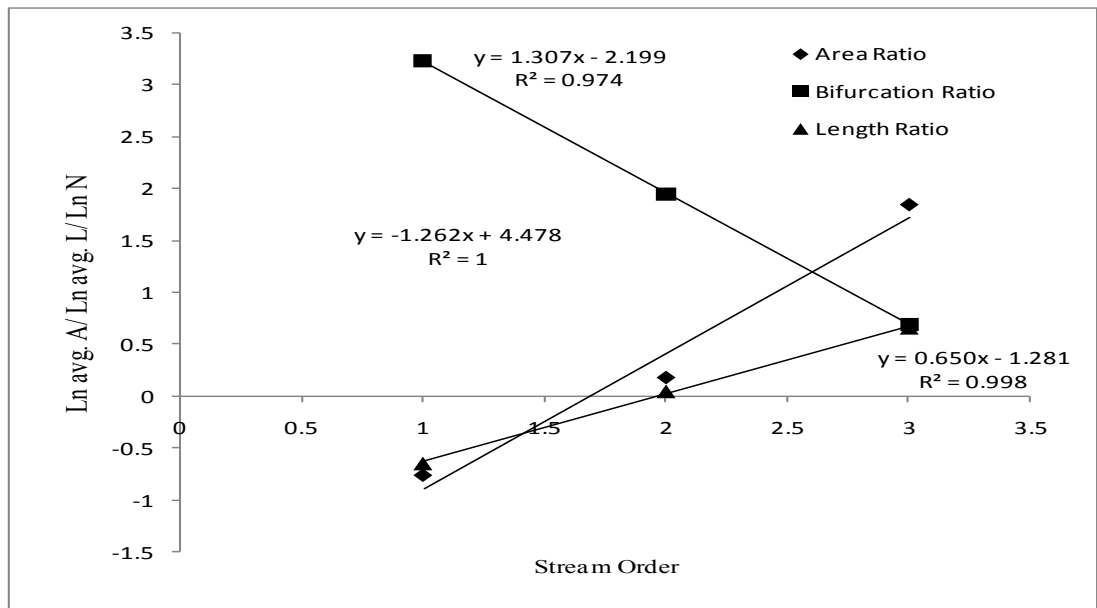

FIGURE 5.24 Estimation of ratios R_A, R_B and R_L for GSW_3^1 .

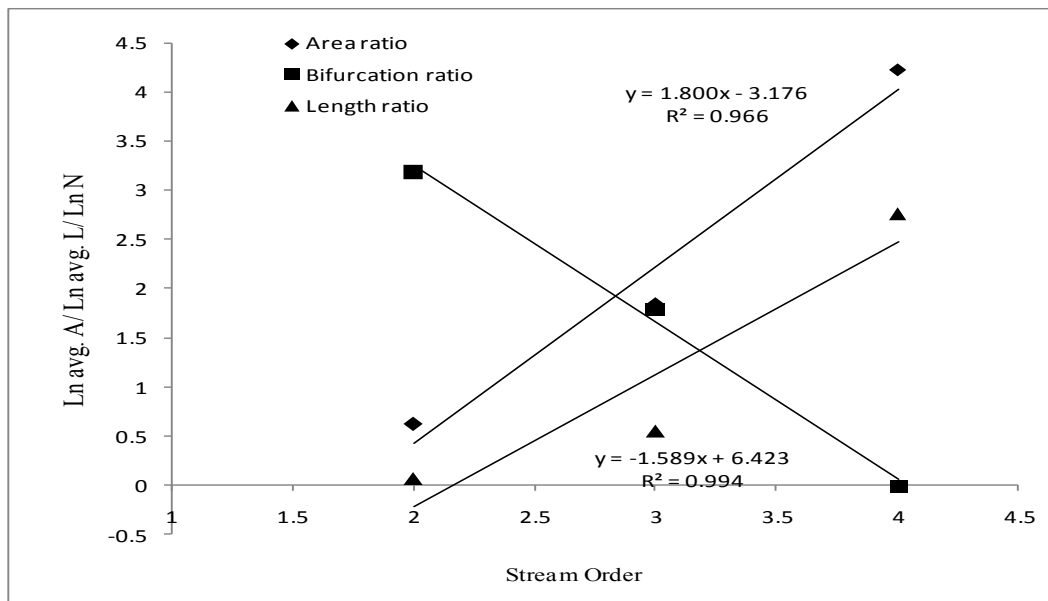

FIGURE 5.25 Estimation of ratios R_A, R_B and R_L for GSW_3^2 .

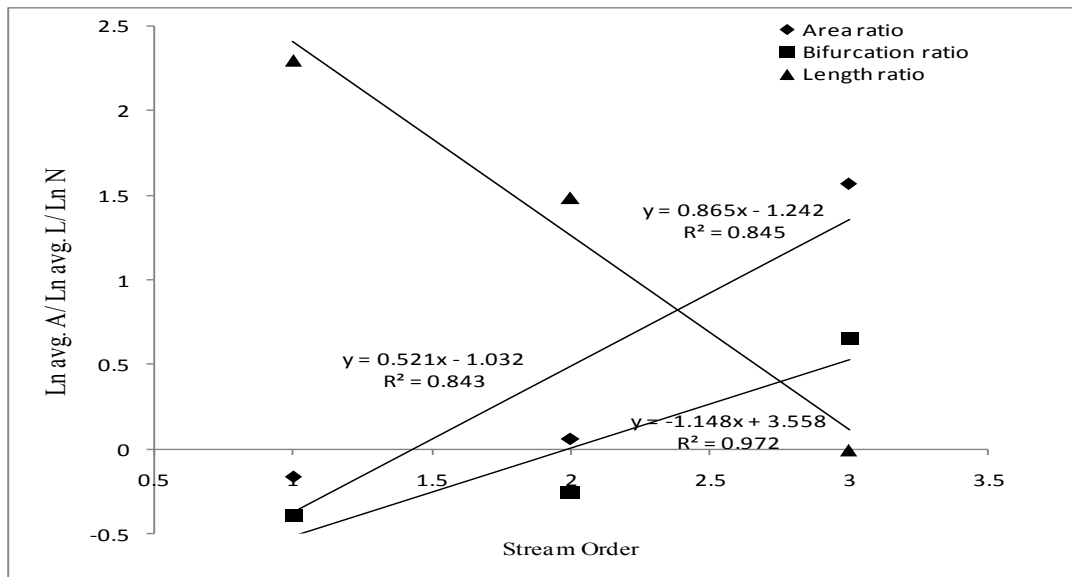

FIGURE 5.26 Estimation of ratios R_A, R_B and R_L for GSW_3^3 .

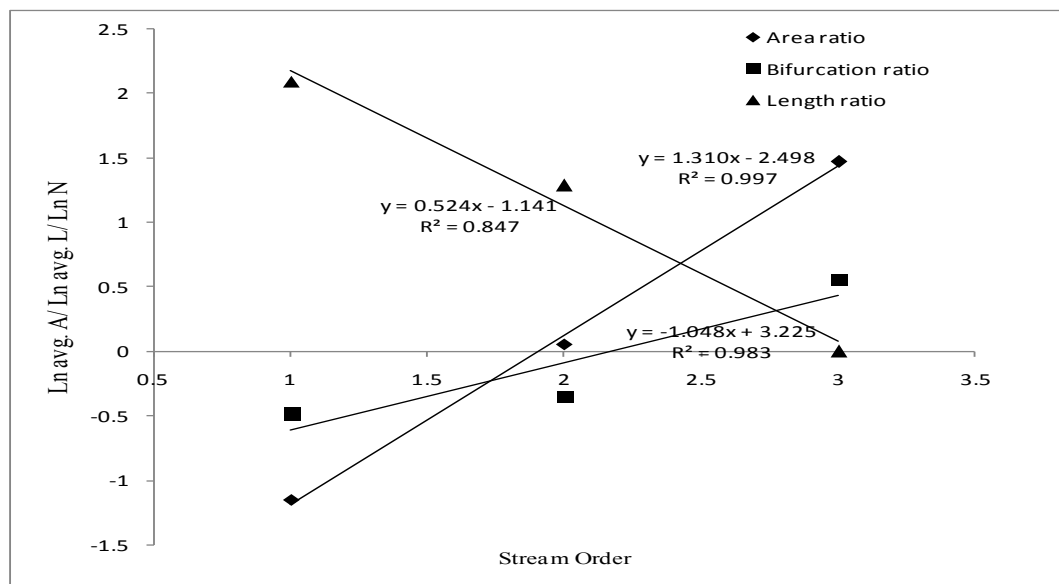

FIGURE 5.27 Estimation of ratios R_A, R_B and R_L for GSW_3^4 .

TABLE 5.1 Geomorphologic characteristics of sub watersheds of Ghagra and Madhura

Sub-watersheds	Area Ratio (R_A)	Length Ratio (R_L)	Bifurcation Ratio (R_B)	Main stream length (L) (km)	Highest Order Stream Length (L_Ω) (km)	Area (A) (km^2)	Average slope (S) (m/m)	Velocity (V) (m/s)
MSW_5^1	4.98	2.56	4.15	38.02	21.39	170.07	0.39	6.74
MSW_5^2	4.09	2.33	3.77	24.83	13.01	73.14	0.27	5.33
MSW_5^3	4.13	1.86	3.56	17.31	4.23	72.78	0.09	3.26
MSW_3^1	3.92	1.87	2.99	7.18	1.94	4.80	0.08	2.54
GSW_5^1	4.38	2.11	3.91	26.15	11.57	163.74	0.09	3.51
GSW_5^2	3.71	1.87	3.29	28.58	8.04	92.17	0.11	3.88
GSW_4^1	4.88	2.71	4.35	23.50	15.88	68.08	0.1	3.57
GSW_4^2	3.49	1.5	3.00	6.89	2.00	21.26	0.08	2.47
GSW_3^1	3.69	1.62	3.11	4.67	2.11	6.33	0.02	1.22
GSW_3^2	3.19	1.56	3.00	3.65	0.80	1.94	0.07	1.97
GSW_3^3	3.69	1.74	3.11	5.88	2.01	7.62	0.02	1.25
GSW_3^4	3.58	1.81	3.21	3.68	1.01	4.56	0.11	2.42

TABLE 5.2 Morphological parameters for the subcatchments

Watershed	Hydraulic flow length (m)	Slope	V(m/s)	L omega(km)	Ra	Rb	RI
GHAGRA	48930	0.098	4.19	19.784	3.90	3.64	2.022
MADHURA	52609	0.28	6.39	14.589	4.305	3.826	2.125
CHIRI	49881	0.23	5.85	11.645	3.815	3.504	1.906
JIRI	103240	0.29	7.56	48.09	4.56	4.21	2.44
KATAKHAL	129880	0.11	5.49	57.43	4.35	4.1	2.406
JATINGA	55390	0.35	7.04	22.93	4.01	4.9	3.089
SONAI	95212	0.07	4.29	15.976	3.5	3.8	1.9251

TABLE 5.3 1hr UH ordinates for MSW_5^3 .

Time (Hours)	GIUH ordinate	GIUH lagged	SUM/2	S-curve addition	S-curve ordinate	lagged by 10x0.1 hr	1hr UH ordinate
0	0		0		0		0
0.1	66.60425	0	33.302125	0	33.30213		3.3302125
0.2	133.2085	66.60425	99.906375	33.302125	133.2085		13.32085
0.3	199.81275	133.2085	166.510625	133.2085	299.7191		29.971913
0.4	266.417	199.81275	233.114875	299.719125	532.834		53.2834
0.5	242.2	266.417	254.3085	532.834	787.1425		78.71425
0.6	217.98	242.2	230.09	787.1425	1017.233		101.72325
0.7	193.76	217.98	205.87	1017.2325	1223.103		122.31025
0.8	169.54	193.76	181.65	1223.1025	1404.753		140.47525
0.9	145.32	169.54	157.43	1404.7525	1562.183		156.21825
1	121.1	145.32	133.21	1562.1825	1695.393	0	169.53925
1.1	96.88	121.1	108.99	1695.3925	1804.383	33.302125	177.10804
1.2	72.66	96.88	84.77	1804.3825	1889.153	133.2085	175.5944
1.3	48.44	72.66	60.55	1889.1525	1949.703	299.719125	164.99834
1.4	24.22	48.44	36.33	1949.7025	1986.033	532.834	145.31985
1.5	0	24.22	12.11	1986.0325	1998.143	787.1425	121.1
1.6		0	0	1998.1425	1998.143	1017.2325	98.091
1.7				1998.1425	1998.143	1223.1025	77.504
1.8				1998.1425	1998.143	1404.7525	59.339
1.9				1998.1425	1998.143	1562.1825	43.596
2				1998.1425	1998.143	1695.3925	30.275
2.1				1998.1425	1998.143	1804.3825	19.376
2.2				1998.1425	1998.143	1889.1525	10.899
2.3				1998.1425	1998.143	1949.7025	4.844
2.4				1998.1425	1998.143	1986.0325	1.211
2.5				1998.1425	1998.143	1998.1425	0
2.6				1998.1425	1998.143	1998.1425	

TABLE 5.4 1hr UH ordinates for GSW_5^1 .

Time (Hours)	GIUH ordinate	GIUH lagged	SUM/2	S-curve addition	S-curve ordinate	lagged by 10x0.1 hr	1hr UH ordinate
0	0		0		0		0
0.1	24.969	0	12.4845	0	12.4845		1.24845
0.2	49.938	24.969	37.4535	12.4845	49.938		4.9938
0.3	74.907	49.938	62.4225	49.938	112.3605		11.23605
0.4	99.876	74.907	87.3915	112.3605	199.752		19.9752
0.5	124.845	99.876	112.3605	199.752	312.1125		31.21125
0.6	149.814	124.845	137.3295	312.1125	449.442		44.9442
0.7	174.783	149.814	162.2985	449.442	611.7405		61.17405
0.8	199.752	174.783	187.2675	611.7405	799.008		79.9008
0.9	224.721	199.752	212.2365	799.008	1011.245		101.1245
1	249.69	224.721	237.2055	1011.245	1248.45	0	124.845
1.1	240.067	249.69	244.8785	1248.45	1493.329	12.4845	148.0844
1.2	230.464	240.067	235.2655	1493.329	1728.594	49.938	167.8656
1.3	220.861	230.464	225.6625	1728.594	1954.257	112.3605	184.1896
1.4	211.258	220.861	216.0595	1954.257	2170.316	199.752	197.0564
1.5	201.655	211.258	206.4565	2170.316	2376.773	312.1125	206.466
1.6	192.052	201.655	196.8535	2376.773	2573.626	449.442	212.4184
1.7	182.449	192.052	187.2505	2573.626	2760.877	611.7405	214.9136
1.8	172.846	182.449	177.6475	2760.877	2938.524	799.008	213.9516
1.9	163.243	172.846	168.0445	2938.524	3106.569	1011.245	209.5324
2	153.64	163.243	158.4415	3106.569	3265.01	1248.45	201.656
2.1	144.037	153.64	148.8385	3265.01	3413.849	1493.329	192.052
2.2	134.434	144.037	139.2355	3413.849	3553.084	1728.594	182.449
2.3	124.831	134.434	129.6325	3553.084	3682.717	1954.257	172.846
2.4	115.228	124.831	120.0295	3682.717	3802.746	2170.316	163.243
2.5	105.625	115.228	110.4265	3802.746	3913.173	2376.773	153.64
2.6	96.022	105.625	100.8235	3913.173	4013.996	2573.626	144.037
2.7	86.419	96.022	91.2205	4013.996	4105.217	2760.877	134.434
2.8	76.816	86.419	81.6175	4105.217	4186.834	2938.524	124.831
2.9	67.213	76.816	72.0145	4186.834	4258.849	3106.569	115.228
3	57.61	67.213	62.4115	4258.849	4321.26	3265.01	105.625
3.1	48.007	57.61	52.8085	4321.26	4374.069	3413.849	96.022
3.2	38.404	48.007	43.2055	4374.069	4417.274	3553.084	86.419
3.3	28.801	38.404	33.6025	4417.274	4450.877	3682.717	76.816
3.4	19.198	28.801	23.9995	4450.877	4474.876	3802.746	67.213
3.5	9.595	19.198	14.3965	4474.876	4489.273	3913.173	57.61
3.6	0	9.595	4.7975	4489.273	4494.07	4013.996	48.0074
3.7		0	0	4494.07	4494.07	4105.217	38.88535
3.8				4494.07	4494.07	4186.834	30.7236
3.9				4494.07	4494.07	4258.849	23.52215

Time (Hours)	GIUH ordinate	GIUH lagged	SUM/2	S-curve addition	S-curve ordinate	lagged by 10x0.1 hr	1hr UH ordinate
4				4494.07	4494.07	4321.26	17.281
4.1				4494.07	4494.07	4374.069	12.00015
4.2				4494.07	4494.07	4417.274	7.6796
4.3				4494.07	4494.07	4450.877	4.31935
4.4				4494.07	4494.07	4474.876	1.9194
4.5				4494.07	4494.07	4489.273	0.47975
4.6				4494.07	4494.07	4494.07	0

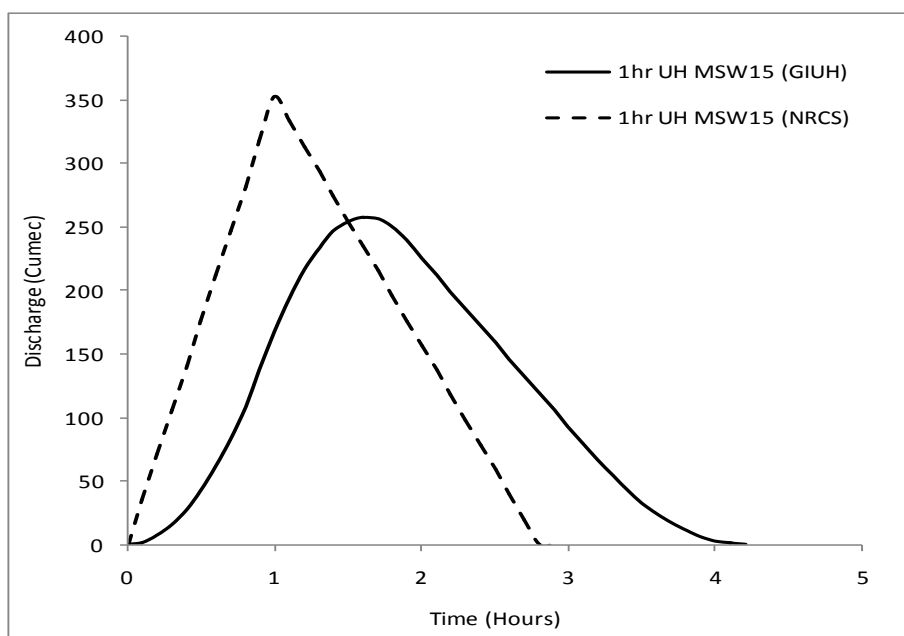

FIGURE 5.28 1hr UH for Madhura sub-watershed MSW_5^1 .

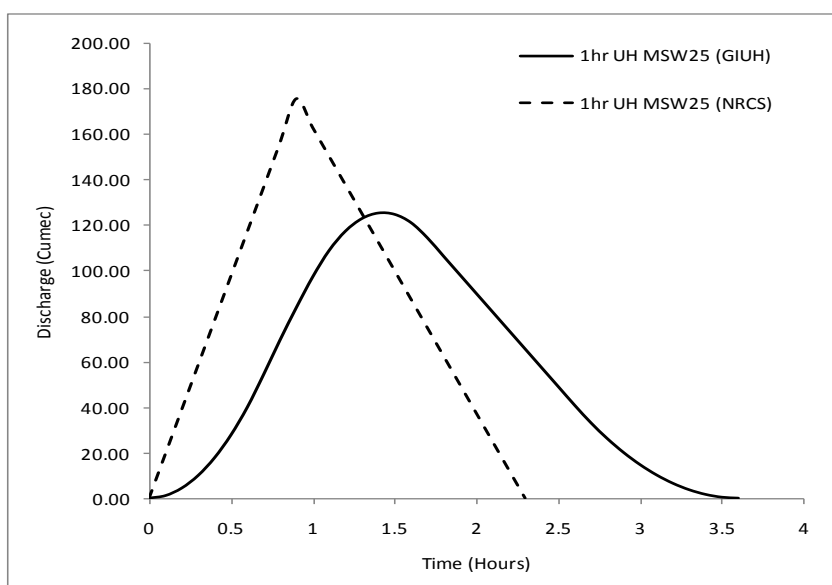

FIGURE 5.29 1hr UH for Madhura sub-watershed MSW_5^2 .

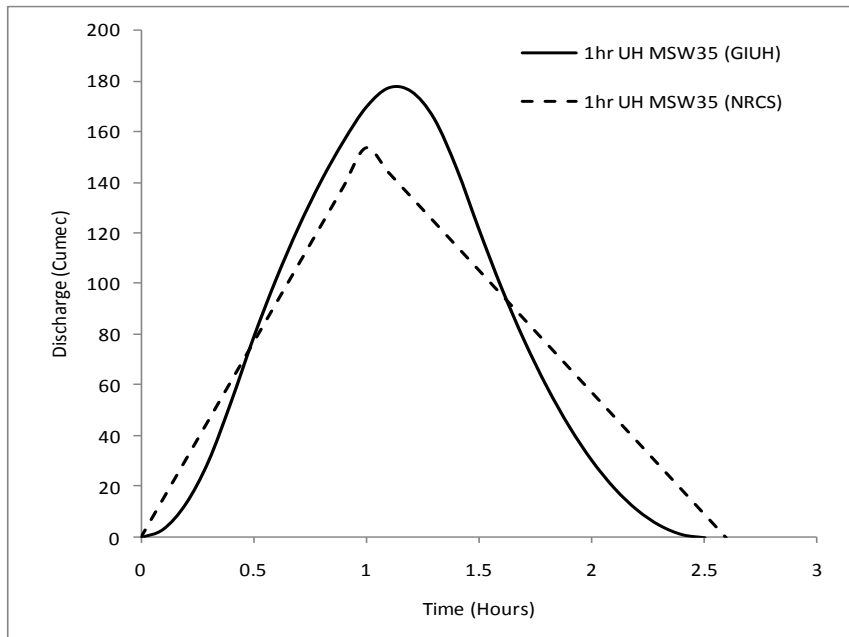

FIGURE 5.30 1hr UH for Madhura sub-watershed MSW_5^3 .

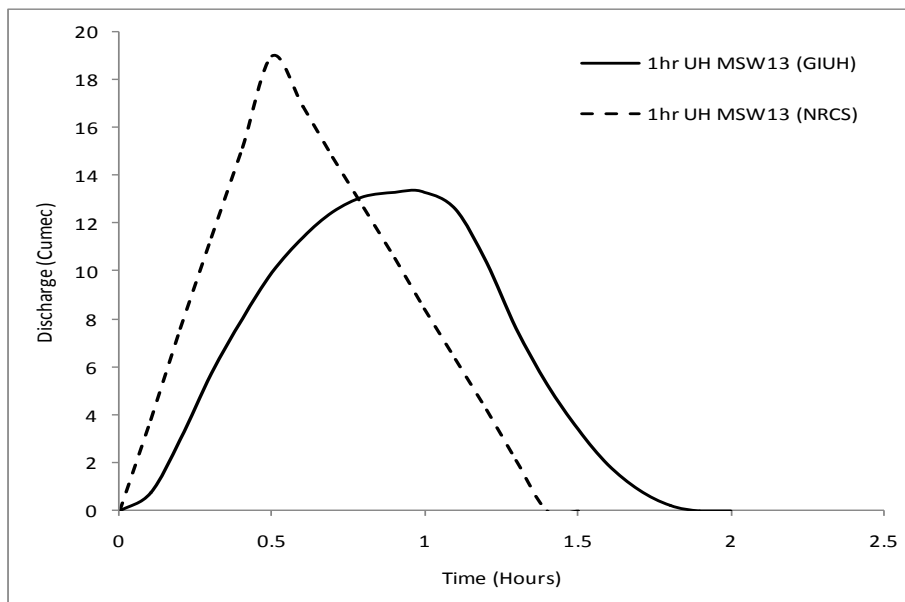

FIGURE 5.31 1hr UH for Madhura sub-watershed MSW_3^1 .

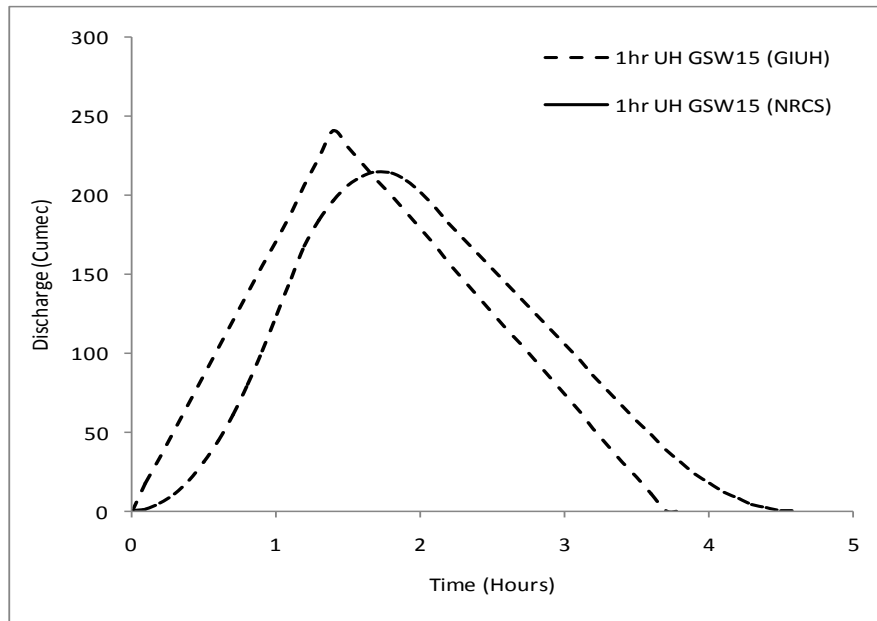

FIGURE 5.32 1hr UH for Ghagra sub-watershed GSW_5^1 .

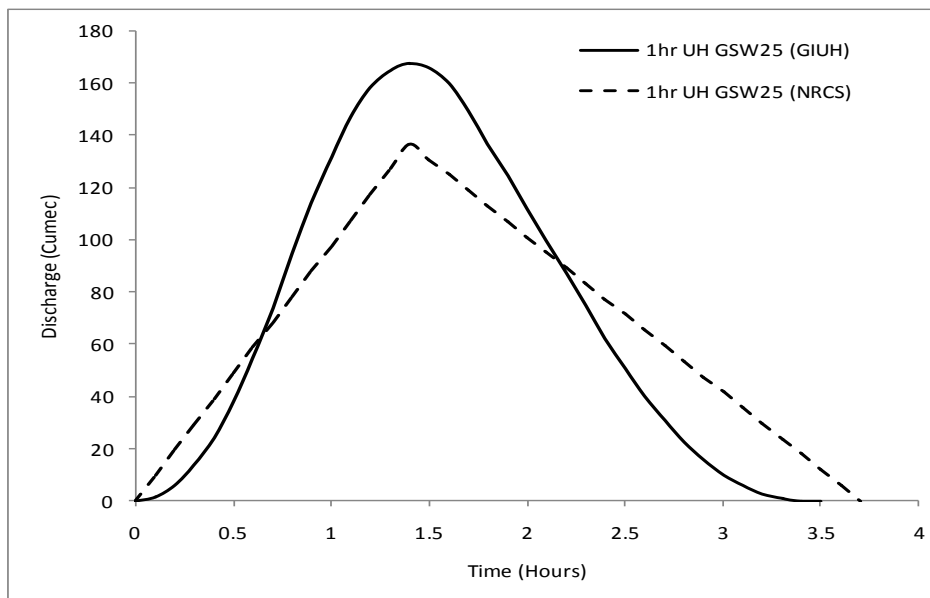

FIGURE 5.33 1hr UH for Ghagra sub-watershed GSW_5^2 .

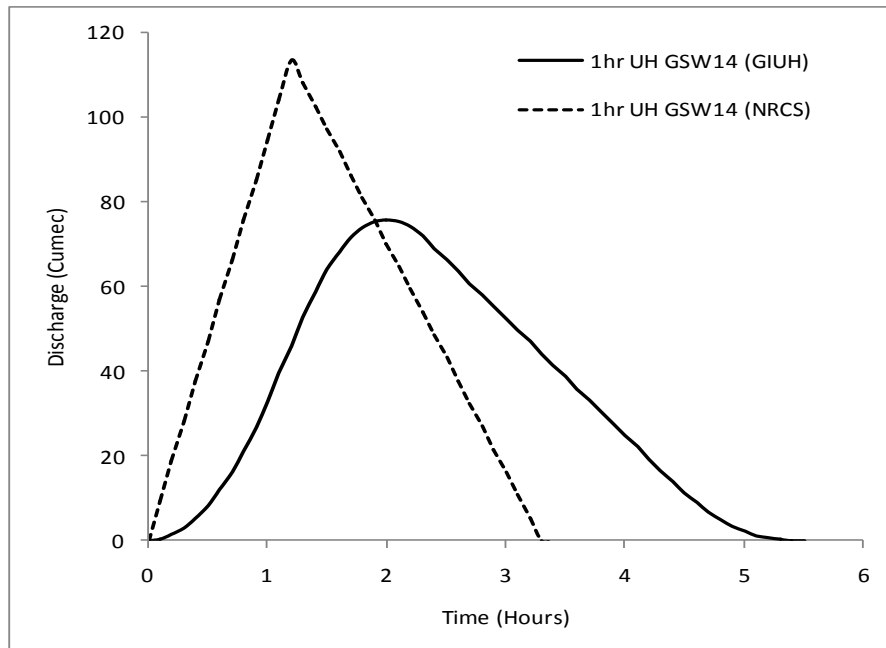

FIGURE 5.34 1hr UH for Ghagra sub-watershed GSW_4^1 .

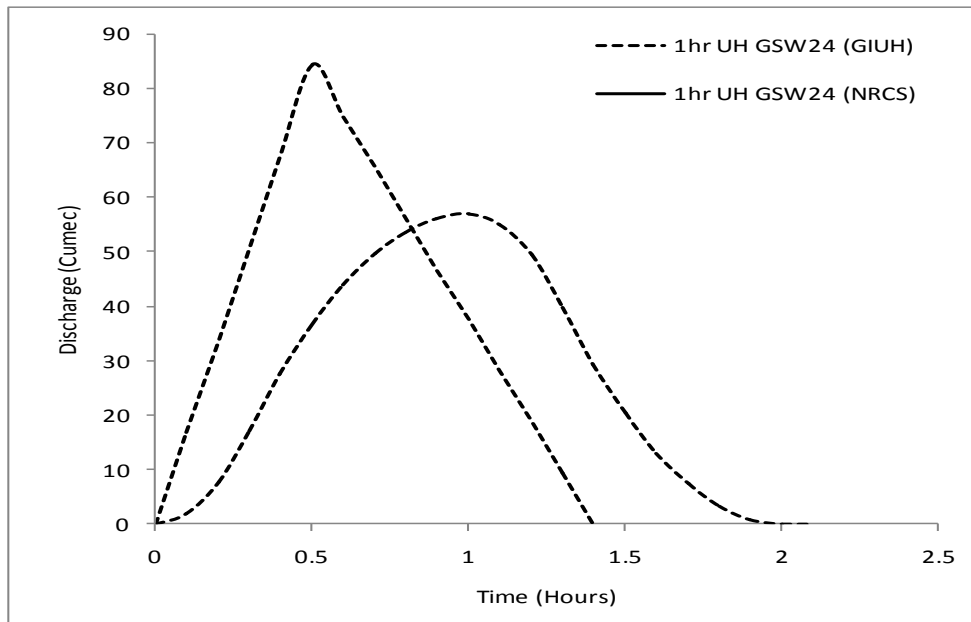

FIGURE 5.35 1hr UH for Ghagra sub-watershed GSW_4^2 .

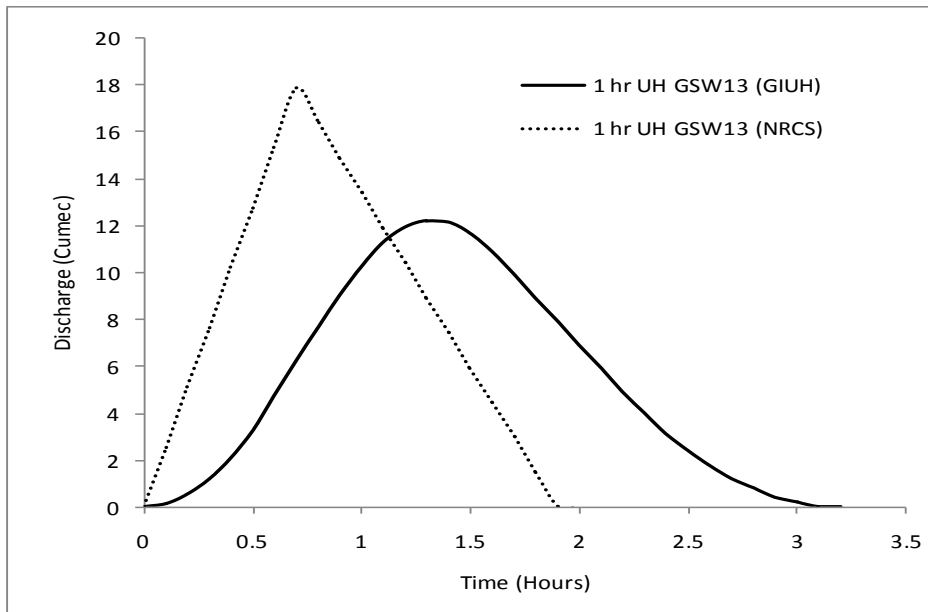

FIGURE 5.36 1hr UH for Ghagra sub-watershed GSW_3^1 .

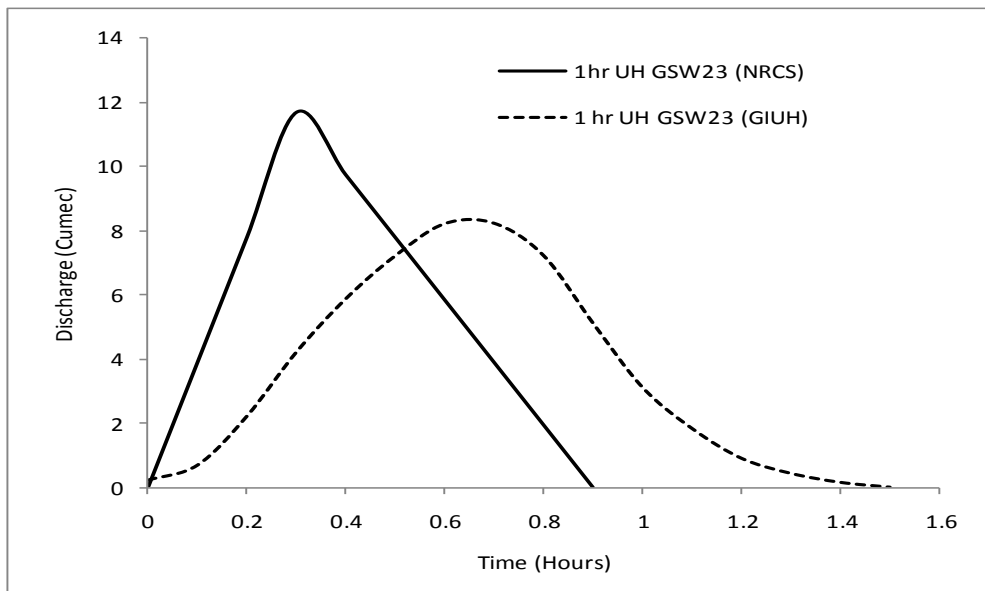

FIGURE 5.37 1hr UH for Ghagra sub-watershed GSW_3^2 .

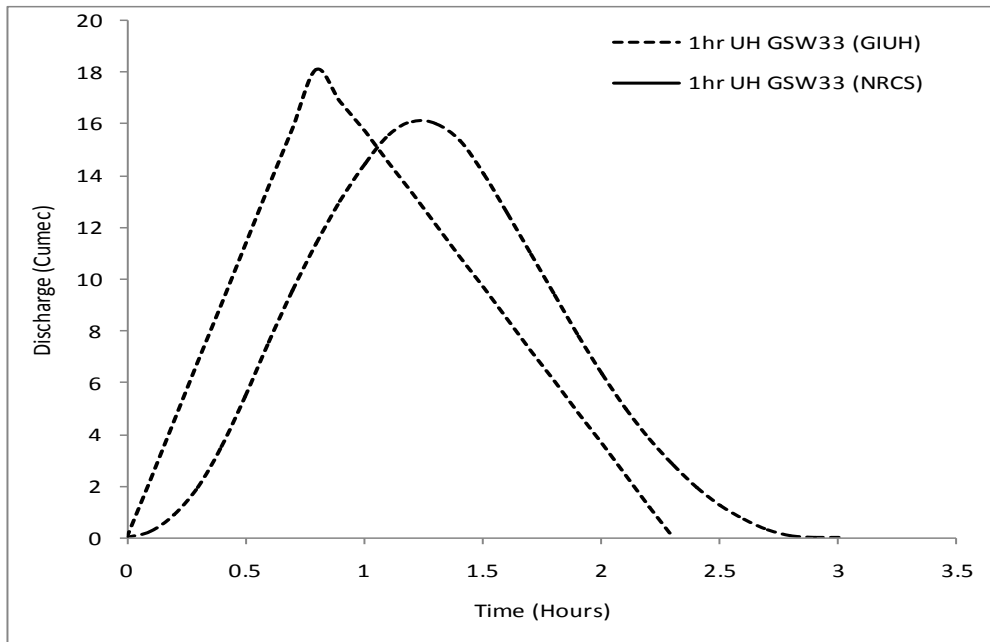

FIGURE 5.38 1hr UH for Ghagra sub-watershed GSW_3^3 .

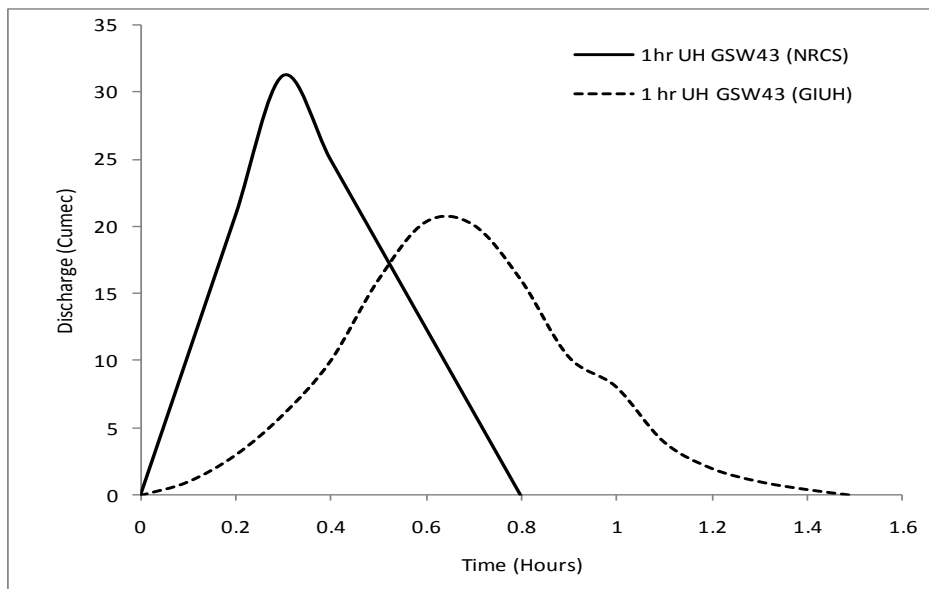

FIGURE 5.39 1hr UH for Ghagra sub-watershed GSW_3^4 .

TABLE 5.5 Unit Hydrograph characteristics for the sub-watersheds.

Watersheds	Time to peak (t_p , hrs)		Peak discharge (Q_p , m^3/s)		Base time (t_b , hrs)	
	GIUH	NRCS	GIUH	NRCS	GIUH	NRCS
MSW_5^1	1.6	1.0	257.78	352.68	4.1	2.8
MSW_5^2	1.4	0.9	125.20	175.28	3.6	2.3
MSW_5^3	1.1	1.0	177.11	153.37	2.5	2.6
MSW_3^1	1.0	0.5	13.32	19.00	1.9	1.5
GSW_5^1	1.7	1.4	214.91	241.08	4.6	3.7
GSW_5^2	1.4	1.4	167.53	136.93	3.5	3.6
GSW_4^1	2.0	1.2	75.81	113.33	5.5	3.4
GSW_4^2	1.0	0.5	56.89	84.30	2.1	1.4
GSW_3^1	1.3	0.7	12.23	17.87	3.2	2.0
GSW_3^2	0.5	0.3	8.23	11.70	1.5	0.9
GSW_3^3	1.2	0.8	16.09	18.11	3.0	2.3
GSW_3^4	0.5	0.4	20.33	24.95	1.5	0.8

5.1 Routing sub-watershed UHs

Sub-watershed UHs derived using GIUH and NRCS techniques are routed by using nonlinear kinematic wave model to the respective main watershed outlet and superimposed with local flows to develop UH for the watersheds. Values for the parameters α and β required for using nonlinear kinematic model are estimated using flow area and corresponding discharge data series for a section. On the basis of maximum top width (W_{max}) and maximum flow depth (Y_{max}) and assuming a parabolic channel section a set of values for the flow area, A_i and corresponding discharge, Q_i are computed. Observed maximum top width and maximum depth for the sub-watershed channel sections in the study sub-watersheds are listed in Table 5.6. Manning's roughness coefficients, n for the reaches are determined using field information, available soil maps and topographic maps etc. n values selected for different channel sections is also given in Table 5.6. Derived values for A_i , and Q_i for a section are used to estimate routing parameters α and β by applying simple nonlinear regression technique. Reach length and estimated routing parameters α and β are listed in Table 5.7.

TABLE 5.6 Channel characteristics and parameters.

Sub-watersheds	Manning Roughness Coefficient (n)	Average channel Slope (S_o) (m/m)	Maximum top Width (W_{max}) (m)	Maximum depth (Y_{max}) (m)
MSW_5^1	0.034	0.337	86.50	4.30
MSW_5^2	0.034	0.273	36.10	6.10
MSW_5^3	0.030	0.095	59.50	8.55
MSW_3^1	0.020	0.084	20.56	3.1
GSW_5^1	0.034	0.380	48.40	5.51
GSW_5^2	0.034	0.350	48.38	5.00
GSW_4^1	0.034	0.400	30.20	7.40
GSW_4^2	0.020	0.254	27.50	4.00
GSW_3^1	0.020	0.080	5.60	1.53
GSW_3^2	0.020	0.071	5.10	1.01
GSW_3^3	0.020	0.074	18.60	4.14
GSW_3^4	0.020	0.062	14.30	3.61

TABLE 5.7 Routing parameters for sub-watersheds.

watersheds	parameters		Reach length (Δx) (km)
	(α)	(β)	
MSW_5^1	0.280	0.750	14.589
MSW_5^2	0.280	0.750	14.589
MSW_5^3	0.321	0.750	0.929
MSW_3^1	0.246	0.750	11.191
GSW_5^1	0.230	0.750	19.784
GSW_5^2	0.232	0.750	19.784
GSW_4^1	0.189	0.750	0.023
GSW_4^2	0.164	0.750	12.794
GSW_3^1	0.097	0.750	17.692
GSW_3^2	0.250	0.750	13.611
GSW_3^3	0.242	0.750	11.227
GSW_3^4	0.255	0.750	1.245

Using values for the routing parameter, α and β for a reach length, (Δx) the sub-watershed UHs are routed to the respective main outlet. To estimate Q_{t+1}^{j+1} initial value for the variable is required, in the present case initial estimate for Q_{t+1}^{j+1} is taken as the estimated value for Q_t^{j+1} , the value of the variable in the previous time step. The resulted UHs are then superimposed to derive the respective UH for the watersheds. Figures 5.40 and Figures 5.41 shows the derived 1hr UH for Madhura and Ghagra watersheds using GIUH and NRCS techniques. Morphological parameters for all sub basins are listed in the table 5.8:

TABLE 5.8 Morphological parameters and IUH Characteristics of subbasins

	Hydraulic flow length (m)	Slope	V (m/s)	$L\omega$ (km)	R_A	R_B	R_L	t_p (hrs)	q_p (-hrs)	q_p (Cumec)	A (Sq. km)	t_b (hrs)	t_b (triangular based)
GHAGRA	48930.00	0.10	4.20	19.78	3.90	3.64	2.02	1.53	0.38	427.64	409.39	5.32	4.08
MADHURA	52609.00	0.28	6.39	14.59	4.31	3.83	2.13	0.71	0.79	858.44	389.43	2.52	1.89
CHIRI	49881.00	0.23	5.85	11.65	3.82	3.50	1.91	0.65	0.87	1057.39	438.12	2.30	1.75
JIRI	103240.00	0.29	7.56	48.09	4.56	4.21	2.44	1.91	0.30	884.39	1052.85	6.61	5.09
KATAKHAL	129880.00	0.11	5.49	57.43	4.35	4.10	2.41	3.19	0.18	763.60	1504.68	10.95	8.52
JATINGA	55390.00	0.35	7.05	22.93	4.01	4.90	3.09	1.04	0.65	675.50	371.86	3.06	2.78
SONAI	95212.00	0.07	4.30	15.98	3.50	3.80	1.93	1.33	0.47	633.14	488.25	4.28	3.56

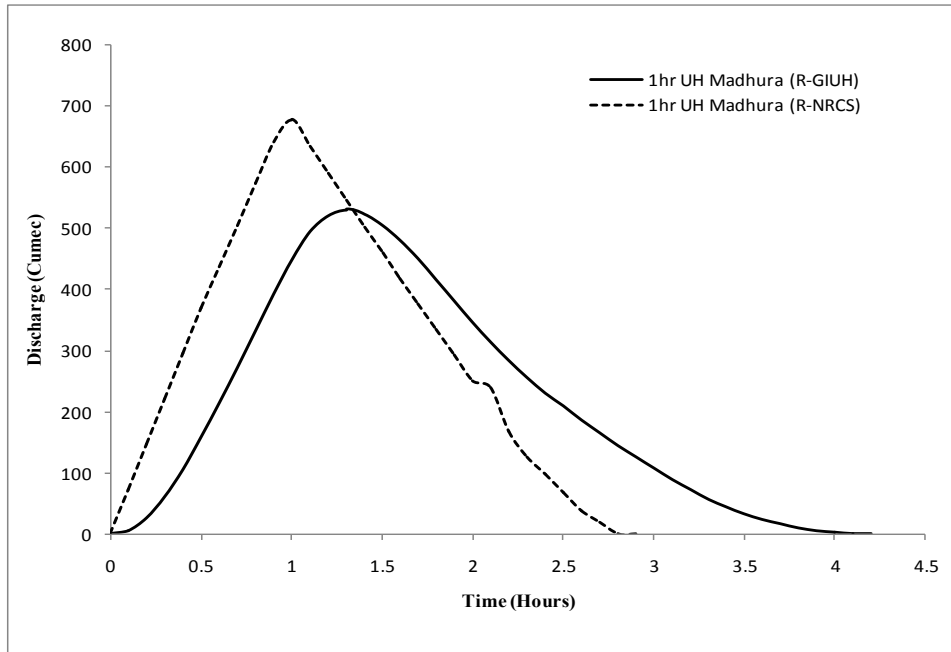

FIGURE 5.40 1hr UH for Machura watershed.

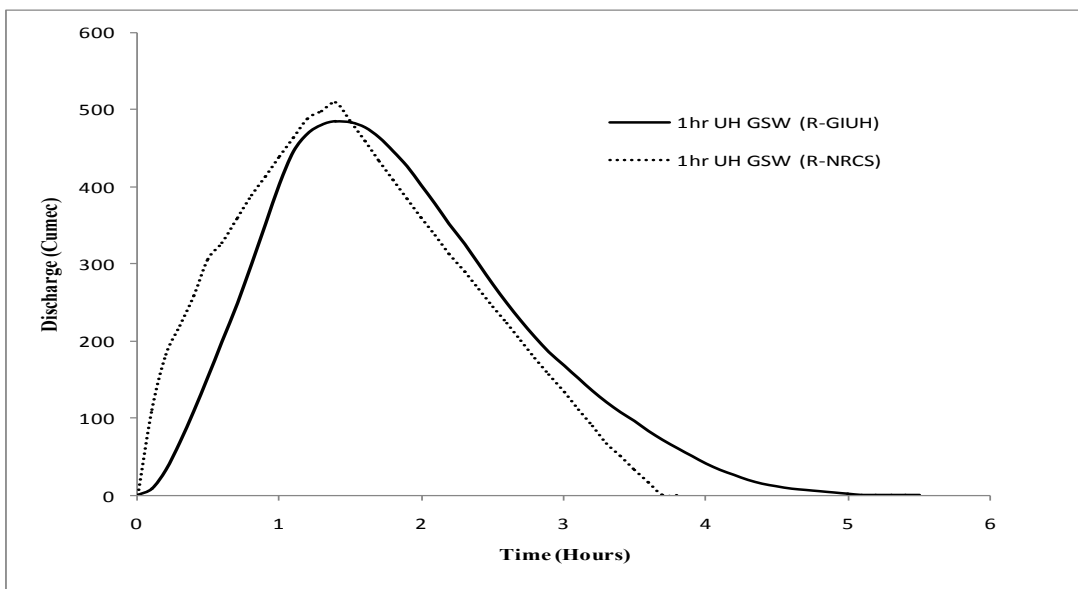

FIGURE 5.41 1hr UH for Ghagra watershed

TABLE 5.9 1hr UH ordinates for Chiri subbasin.

Time (Hours)	GIUH ordinate	GIUH lagged	SUM/2	S-curve addition	S-curve ordinate	lagged by 10x0.1 hr	1hr UH ordinate
0	0.00		0.00		0.00		0.00
0.1	151.06	0.00	75.53	0.00	75.53		7.55
0.2	302.11	151.06	226.58	75.53	302.11		30.21
0.3	453.17	302.11	377.64	302.11	679.75		67.98
0.4	604.22	453.17	528.70	679.75	1208.45		120.84
0.5	755.28	604.22	679.75	1208.45	1888.20		188.82
0.6	906.33	755.28	830.81	1888.20	2719.00		271.90
0.7	1057.39	906.33	981.86	2719.00	3700.87		370.09
0.8	991.36	1057.39	1024.38	3700.87	4725.24		472.52
0.9	925.28	991.36	958.32	4725.24	5683.56		568.36
1	859.20	925.28	892.24	5683.56	6575.80	0.00	657.58
1.1	793.12	859.20	826.16	6575.80	7401.96	75.53	732.64
1.2	727.04	793.12	760.08	7401.96	8162.04	302.11	785.99
1.3	660.96	727.04	694.00	8162.04	8856.04	679.75	817.63
1.4	594.88	660.96	627.92	8856.04	9483.96	1208.45	827.55
1.5	528.80	594.88	561.84	9483.96	10045.80	1888.20	815.76
1.6	462.72	528.80	495.76	10045.80	10541.56	2719.00	782.26
1.7	396.64	462.72	429.68	10541.56	10971.24	3700.87	727.04
1.8	330.56	396.64	363.60	10971.24	11334.84	4725.24	660.96
1.9	264.48	330.56	297.52	11334.84	11632.36	5683.56	594.88
2	198.40	264.48	231.44	11632.36	11863.80	6575.80	528.80
2.1	132.32	198.40	165.36	11863.80	12029.16	7401.96	462.72
2.2	66.24	132.32	99.28	12029.16	12128.44	8162.04	396.64
2.3	0.16	66.24	33.20	12128.44	12161.64	8856.04	330.56
2.4		0.16	0.08	12161.64	12161.72	9483.96	267.78
2.5				12161.72	12161.72	10045.80	211.59
2.6				12161.72	12161.72	10541.56	162.02
2.7				12161.72	12161.72	10971.24	119.05
2.8				12161.72	12161.72	11334.84	82.69
2.9				12161.72	12161.72	11632.36	52.94
3				12161.72	12161.72	11863.80	29.79
3.1				12161.72	12161.72	12029.16	13.26
3.2				12161.72	12161.72	12128.44	3.33
3.3				12161.72	12161.72	12161.64	0.01
3.4				12161.72	12161.72	12161.72	0.00

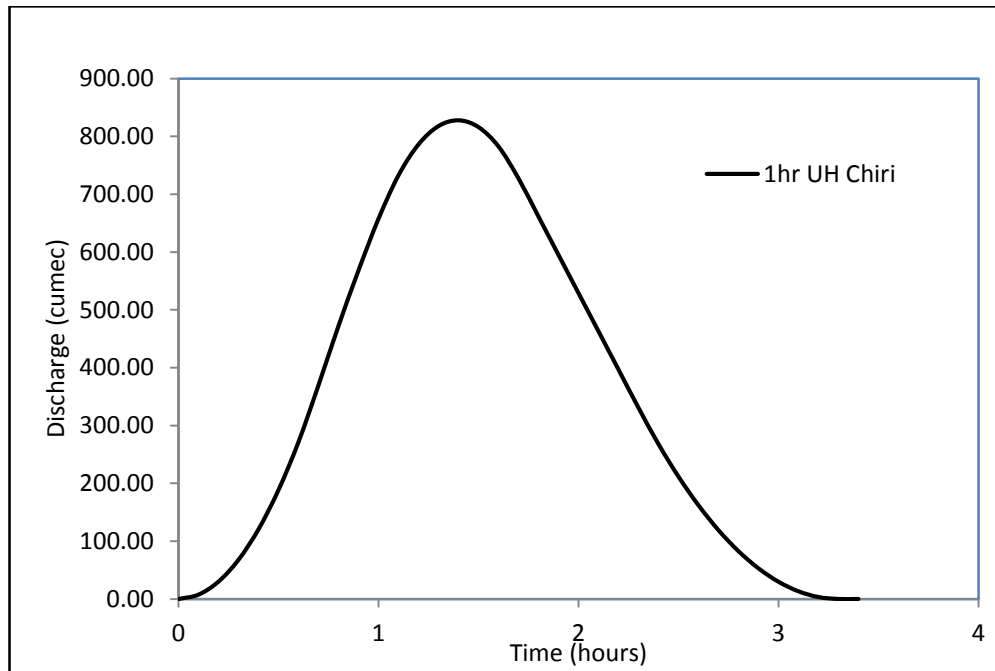

FIGURE 5.42 1hr UH ordinates for Chiri subbasin

TABLE 5.10 1hr UH ordinates for Jiri subbasin.

Time (Hours)	GIUH ordinate	GIUH lagged	SUM/2	S-curve addition	S-curve ordinate	lagged by 10x0.1 hr	1hrUH ordinate
0	0.00		0.00		0.00		0.00
0.1	46.55	0.00	23.27	0.00	23.27		2.33
0.2	93.09	46.55	69.82	23.27	93.09		9.31
0.3	139.64	93.09	116.37	93.09	209.46		20.95
0.4	186.19	139.64	162.91	209.46	372.37		37.24
0.5	232.73	186.19	209.46	372.37	581.83		58.18
0.6	279.28	232.73	256.01	581.83	837.84		83.78
0.7	325.83	279.28	302.55	837.84	1140.39		114.04
0.8	372.37	325.83	349.10	1140.39	1489.49		148.95
0.9	418.92	372.37	395.65	1489.49	1885.14		188.51
1	465.47	418.92	442.19	1885.14	2327.33	0.00	232.73
1.1	512.01	465.47	488.74	2327.33	2816.07	23.27	279.28
1.2	558.56	512.01	535.29	2816.07	3351.36	93.09	325.83

Flood Damage Mitigation: Report

1.3	605.11	558.56	581.83	3351.36	3933.19	209.46	372.37
1.4	651.65	605.11	628.38	3933.19	4561.57	372.37	418.92
1.5	698.20	651.65	674.93	4561.57	5236.50	581.83	465.47
1.6	744.75	698.20	721.47	5236.50	5957.97	837.84	512.01
1.7	791.29	744.75	768.02	5957.97	6725.99	1140.39	558.56
1.8	837.84	791.29	814.57	6725.99	7540.55	1489.49	605.11
1.9	884.39	837.84	861.11	7540.55	8401.67	1885.14	651.65
2	864.80	884.39	874.59	8401.67	9276.26	2327.33	694.89
2.1	845.99	864.80	855.40	9276.26	10131.66	2816.07	731.56
2.2	827.18	845.99	836.59	10131.66	10968.24	3351.36	761.69
2.3	808.37	827.18	817.78	10968.24	11786.02	3933.19	785.28
2.4	789.56	808.37	798.97	11786.02	12584.98	4561.57	802.34
2.5	770.75	789.56	780.16	12584.98	13365.14	5236.50	812.86
2.6	751.94	770.75	761.35	13365.14	14126.48	5957.97	816.85
2.7	733.13	751.94	742.54	14126.48	14869.02	6725.99	814.30
2.8	714.32	733.13	723.73	14869.02	15592.74	7540.55	805.22
2.9	695.51	714.32	704.92	15592.74	16297.66	8401.67	789.60
3	676.70	695.51	686.11	16297.66	16983.76	9276.26	770.75
3.1	657.89	676.70	667.30	16983.76	17651.06	10131.66	751.94
3.2	639.08	657.89	648.49	17651.06	18299.54	10968.24	733.13
3.3	620.27	639.08	629.68	18299.54	18929.22	11786.02	714.32
3.4	601.46	620.27	610.87	18929.22	19540.08	12584.98	695.51
3.5	582.65	601.46	592.06	19540.08	20132.14	13365.14	676.70
3.6	563.84	582.65	573.25	20132.14	20705.38	14126.48	657.89
3.7	545.03	563.84	554.44	20705.38	21259.82	14869.02	639.08
3.8	526.22	545.03	535.63	21259.82	21795.44	15592.74	620.27
3.9	507.41	526.22	516.82	21795.44	22312.26	16297.66	601.46
4	488.60	507.41	498.01	22312.26	22810.26	16983.76	582.65
4.1	469.79	488.60	479.20	22810.26	23289.46	17651.06	563.84
4.2	450.98	469.79	460.39	23289.46	23749.84	18299.54	545.03
4.3	432.17	450.98	441.58	23749.84	24191.42	18929.22	526.22
4.4	413.36	432.17	422.77	24191.42	24614.18	19540.08	507.41
4.5	394.55	413.36	403.96	24614.18	25018.14	20132.14	488.60
4.6	375.74	394.55	385.15	25018.14	25403.28	20705.38	469.79

Flood Damage Mitigation: Report

4.7	356.93	375.74	366.34	25403.28	25769.62	21259.82	450.98
4.8	338.12	356.93	347.53	25769.62	26117.14	21795.44	432.17
4.9	319.31	338.12	328.72	26117.14	26445.86	22312.26	413.36
5	300.50	319.31	309.91	26445.86	26755.76	22810.26	394.55
5.1	281.69	300.50	291.10	26755.76	27046.86	23289.46	375.74
5.2	262.88	281.69	272.29	27046.86	27319.14	23749.84	356.93
5.3	244.07	262.88	253.48	27319.14	27572.62	24191.42	338.12
5.4	225.26	244.07	234.67	27572.62	27807.28	24614.18	319.31
5.5	206.45	225.26	215.86	27807.28	28023.14	25018.14	300.50
5.6	187.64	206.45	197.05	28023.14	28220.18	25403.28	281.69
5.7	168.83	187.64	178.24	28220.18	28398.42	25769.62	262.88
5.8	150.02	168.83	159.43	28398.42	28557.84	26117.14	244.07
5.9	131.21	150.02	140.62	28557.84	28698.46	26445.86	225.26
6	112.40	131.21	121.81	28698.46	28820.26	26755.76	206.45
6.1	93.59	112.40	103.00	28820.26	28923.26	27046.86	187.64
6.2	74.78	93.59	84.19	28923.26	29007.44	27319.14	168.83
6.3	55.97	74.78	65.38	29007.44	29072.82	27572.62	150.02
6.4	37.16	55.97	46.57	29072.82	29119.38	27807.28	131.21
6.5	18.35	37.16	27.76	29119.38	29147.14	28023.14	112.40
6.6	0.00	18.35	9.18	29147.14	29156.31	28220.18	93.61
6.7		0.00	0.00	29156.31	29156.31	28398.42	75.79
6.8				29156.31	29156.31	28557.84	59.85
6.9				29156.31	29156.31	28698.46	45.79
7				29156.31	29156.31	28820.26	33.61
7.1				29156.31	29156.31	28923.26	23.31
7.2				29156.31	29156.31	29007.44	14.89
7.3				29156.31	29156.31	29072.82	8.35
7.4				29156.31	29156.31	29119.38	3.69
7.5				29156.31	29156.31	29147.14	0.92
7.6				29156.31	29156.31	29156.31	0.00

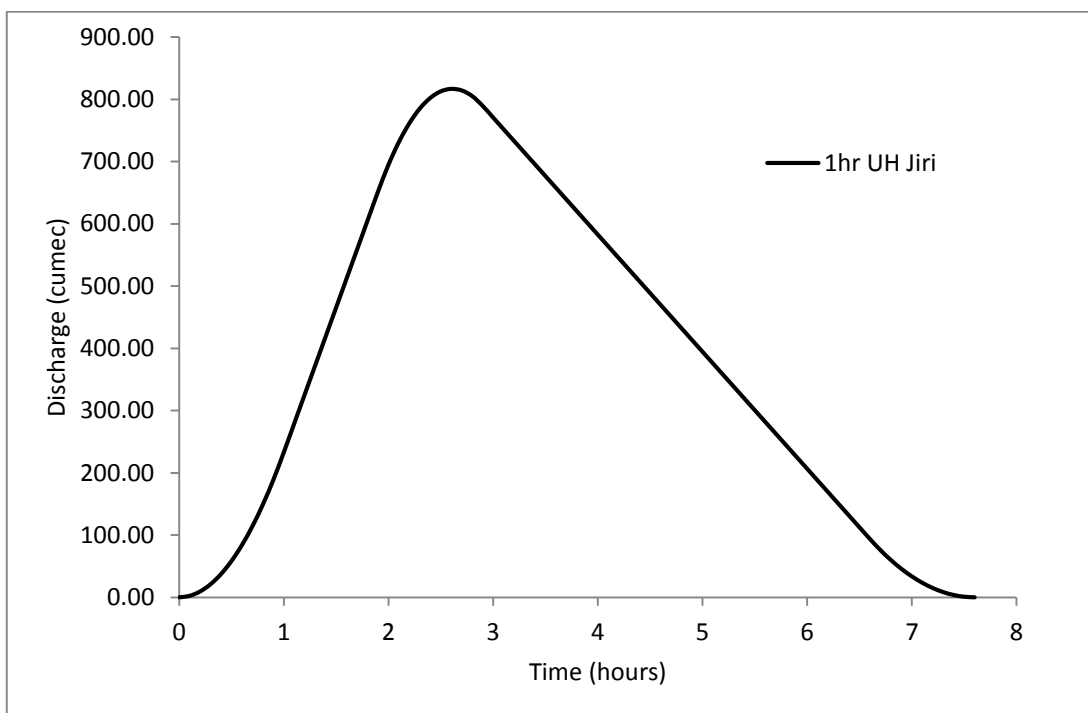

FIGURE 5.4 1hr UH ordinates for Jiri subbasin

TABLE 5.11 1hr UH ordinates for Jatinga subbasin.

Time (Hours)	GIUH ordinate	GIUH lagged	SUM/2	S-curve addition	S-curve ordinate	lagged by 10x0.1 hr	1hr UH ordinate
0	0.00		0.00		0.00		0.00
0.1	46.55	0.00	23.27	0.00	23.27		2.33
0.2	93.09	46.55	69.82	23.27	93.09		9.31
0.3	139.64	93.09	116.37	93.09	209.46		20.95
0.4	186.19	139.64	162.91	209.46	372.37		37.24
0.5	232.73	186.19	209.46	372.37	581.83		58.18
0.6	279.28	232.73	256.01	581.83	837.84		83.78
0.7	325.83	279.28	302.55	837.84	1140.39		114.04
0.8	372.37	325.83	349.10	1140.39	1489.49		148.95
0.9	418.92	372.37	395.65	1489.49	1885.14		188.51
1	465.47	418.92	442.19	1885.14	2327.33	0.00	232.73
1.1	512.01	465.47	488.74	2327.33	2816.07	23.27	279.28
1.2	558.56	512.01	535.29	2816.07	3351.36	93.09	325.83
1.3	605.11	558.56	581.83	3351.36	3933.19	209.46	372.37

Flood Damage Mitigation: Report

1.4	651.65	605.11	628.38	3933.19	4561.57	372.37	418.92
1.5	698.20	651.65	674.93	4561.57	5236.50	581.83	465.47
1.6	744.75	698.20	721.47	5236.50	5957.97	837.84	512.01
1.7	791.29	744.75	768.02	5957.97	6725.99	1140.39	558.56
1.8	837.84	791.29	814.57	6725.99	7540.55	1489.49	605.11
1.9	884.39	837.84	861.11	7540.55	8401.67	1885.14	651.65
2	864.80	884.39	874.59	8401.67	9276.26	2327.33	694.89
2.1	845.99	864.80	855.40	9276.26	10131.66	2816.07	731.56
2.2	827.18	845.99	836.59	10131.66	10968.24	3351.36	761.69
2.3	808.37	827.18	817.78	10968.24	11786.02	3933.19	785.28
2.4	789.56	808.37	798.97	11786.02	12584.98	4561.57	802.34
2.5	770.75	789.56	780.16	12584.98	13365.14	5236.50	812.86
2.6	751.94	770.75	761.35	13365.14	14126.48	5957.97	816.85
2.7	733.13	751.94	742.54	14126.48	14869.02	6725.99	814.30
2.8	714.32	733.13	723.73	14869.02	15592.74	7540.55	805.22
2.9	695.51	714.32	704.92	15592.74	16297.66	8401.67	789.60
3	676.70	695.51	686.11	16297.66	16983.76	9276.26	770.75
3.1	657.89	676.70	667.30	16983.76	17651.06	10131.66	751.94
3.2	639.08	657.89	648.49	17651.06	18299.54	10968.24	733.13
3.3	620.27	639.08	629.68	18299.54	18929.22	11786.02	714.32
3.4	601.46	620.27	610.87	18929.22	19540.08	12584.98	695.51
3.5	582.65	601.46	592.06	19540.08	20132.14	13365.14	676.70
3.6	563.84	582.65	573.25	20132.14	20705.38	14126.48	657.89
3.7	545.03	563.84	554.44	20705.38	21259.82	14869.02	639.08
3.8	526.22	545.03	535.63	21259.82	21795.44	15592.74	620.27
3.9	507.41	526.22	516.82	21795.44	22312.26	16297.66	601.46
4	488.60	507.41	498.01	22312.26	22810.26	16983.76	582.65
4.1	469.79	488.60	479.20	22810.26	23289.46	17651.06	563.84
4.2	450.98	469.79	460.39	23289.46	23749.84	18299.54	545.03
4.3	432.17	450.98	441.58	23749.84	24191.42	18929.22	526.22
4.4	413.36	432.17	422.77	24191.42	24614.18	19540.08	507.41
4.5	394.55	413.36	403.96	24614.18	25018.14	20132.14	488.60
4.6	375.74	394.55	385.15	25018.14	25403.28	20705.38	469.79
4.7	356.93	375.74	366.34	25403.28	25769.62	21259.82	450.98

Flood Damage Mitigation: Report

4.8	338.12	356.93	347.53	25769.62	26117.14	21795.44	432.17
4.9	319.31	338.12	328.72	26117.14	26445.86	22312.26	413.36
5	300.50	319.31	309.91	26445.86	26755.76	22810.26	394.55
5.1	281.69	300.50	291.10	26755.76	27046.86	23289.46	375.74
5.2	262.88	281.69	272.29	27046.86	27319.14	23749.84	356.93
5.3	244.07	262.88	253.48	27319.14	27572.62	24191.42	338.12
5.4	225.26	244.07	234.67	27572.62	27807.28	24614.18	319.31
5.5	206.45	225.26	215.86	27807.28	28023.14	25018.14	300.50
5.6	187.64	206.45	197.05	28023.14	28220.18	25403.28	281.69
5.7	168.83	187.64	178.24	28220.18	28398.42	25769.62	262.88
5.8	150.02	168.83	159.43	28398.42	28557.84	26117.14	244.07
5.9	131.21	150.02	140.62	28557.84	28698.46	26445.86	225.26
6	112.40	131.21	121.81	28698.46	28820.26	26755.76	206.45
6.1	93.59	112.40	103.00	28820.26	28923.26	27046.86	187.64
6.2	74.78	93.59	84.19	28923.26	29007.44	27319.14	168.83
6.3	55.97	74.78	65.38	29007.44	29072.82	27572.62	150.02
6.4	37.16	55.97	46.57	29072.82	29119.38	27807.28	131.21
6.5	18.35	37.16	27.76	29119.38	29147.14	28023.14	112.40
6.6	0.00	18.35	9.18	29147.14	29156.31	28220.18	93.61
6.7		0.00	0.00	29156.31	29156.31	28398.42	75.79
6.8				29156.31	29156.31	28557.84	59.85
6.9				29156.31	29156.31	28698.46	45.79
7				29156.31	29156.31	28820.26	33.61
7.1				29156.31	29156.31	28923.26	23.31
7.2				29156.31	29156.31	29007.44	14.89
7.3				29156.31	29156.31	29072.82	8.35
7.4				29156.31	29156.31	29119.38	3.69
7.5				29156.31	29156.31	29147.14	0.92
7.6				29156.31	29156.31	29156.31	0.00

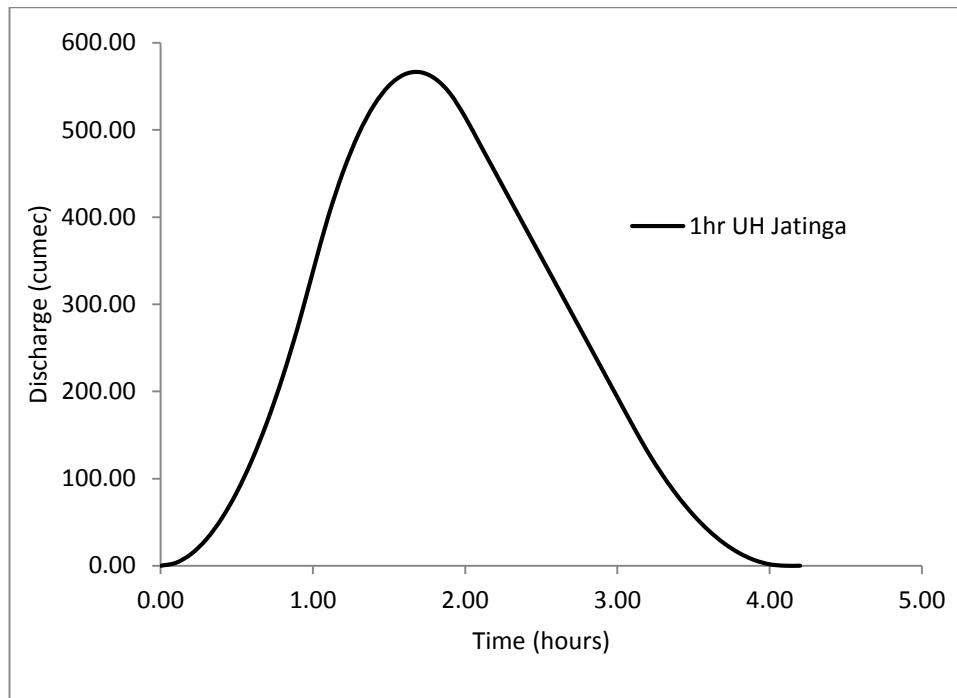

FIGURE 5.44 1hr UH ordinates for Jhatinga subbasin

TABLE 5.12 1hr UH ordinates for Sonai subbasin.

Time (Hours)	GIUH ordinate	GIUH lagged	SUM/2	S-curve addition	S-curve ordinate	lagged by 10x0.1 hr	1hrUH ordinate
0.00	0.00		0.00		0.00		0.00
0.10	48.70	0.00	24.35	0.00	24.35		2.44
0.20	97.41	48.70	73.05	24.35	97.41		9.74
0.30	146.11	97.41	121.76	97.41	219.16		21.92
0.40	194.81	146.11	170.46	219.16	389.62		38.96
0.50	243.51	194.81	219.16	389.62	608.79		60.88
0.60	292.22	243.51	267.87	608.79	876.65		87.67
0.70	340.92	292.22	316.57	876.65	1193.22		119.32
0.80	389.62	340.92	365.27	1193.22	1558.49		155.85
0.90	438.33	389.62	413.97	1558.49	1972.47		197.25
1.00	487.03	438.33	462.68	1972.47	2435.15	0.00	243.51
1.10	535.73	487.03	511.38	2435.15	2946.53	24.35	292.22
1.20	584.43	535.73	560.08	2946.53	3506.61	97.41	340.92
1.30	633.14	584.43	608.79	3506.61	4115.40	219.16	389.62
1.40	612.10	633.14	622.62	4115.40	4738.01	389.62	434.84

Flood Damage Mitigation: Report

1.50	591.00	612.10	601.55	4738.01	5339.56	608.79	473.08
1.60	569.90	591.00	580.45	5339.56	5920.01	876.65	504.34
1.70	548.80	569.90	559.35	5920.01	6479.36	1193.22	528.61
1.80	527.70	548.80	538.25	6479.36	7017.61	1558.49	545.91
1.90	506.60	527.70	517.15	7017.61	7534.76	1972.47	556.23
2.00	485.50	506.60	496.05	7534.76	8030.81	2435.15	559.57
2.10	464.40	485.50	474.95	8030.81	8505.76	2946.53	555.92
2.20	443.30	464.40	453.85	8505.76	8959.61	3506.61	545.30
2.30	422.20	443.30	432.75	8959.61	9392.36	4115.40	527.70
2.40	401.10	422.20	411.65	9392.36	9804.01	4738.01	506.60
2.50	380.00	401.10	390.55	9804.01	10194.56	5339.56	485.50
2.60	358.90	380.00	369.45	10194.56	10564.01	5920.01	464.40
2.70	337.80	358.90	348.35	10564.01	10912.36	6479.36	443.30
2.80	316.70	337.80	327.25	10912.36	11239.61	7017.61	422.20
2.90	295.60	316.70	306.15	11239.61	11545.76	7534.76	401.10
3.00	274.50	295.60	285.05	11545.76	11830.81	8030.81	380.00
3.10	253.40	274.50	263.95	11830.81	12094.76	8505.76	358.90
3.20	232.30	253.40	242.85	12094.76	12337.61	8959.61	337.80
3.30	211.20	232.30	221.75	12337.61	12559.36	9392.36	316.70
3.40	190.10	211.20	200.65	12559.36	12760.01	9804.01	295.60
3.50	169.00	190.10	179.55	12760.01	12939.56	10194.56	274.50
3.60	147.90	169.00	158.45	12939.56	13098.01	10564.01	253.40
3.70	126.80	147.90	137.35	13098.01	13235.36	10912.36	232.30
3.80	105.70	126.80	116.25	13235.36	13351.61	11239.61	211.20
3.90	84.60	105.70	95.15	13351.61	13446.76	11545.76	190.10
4.00	63.50	84.60	74.05	13446.76	13520.81	11830.81	169.00
4.10	42.40	63.50	52.95	13520.81	13573.76	12094.76	147.90
4.20	21.30	42.40	31.85	13573.76	13605.61	12337.61	126.80
4.30	0.20	21.30	10.75	13605.61	13616.36	12559.36	105.70
4.40	0.00	0.20	0.10	13616.36	13616.46	12760.01	85.64
4.50		0.00	0.00	13616.46	13616.46	12939.56	67.69
4.60				13616.46	13616.46	13098.01	51.84
4.70				13616.46	13616.46	13235.36	38.11
4.80				13616.46	13616.46	13351.61	26.48

4.90				13616.46	13616.46	13446.76	16.97
5.00				13616.46	13616.46	13520.81	9.56
5.10				13616.46	13616.46	13573.76	4.27
5.20				13616.46	13616.46	13605.61	1.09
5.30				13616.46	13616.46	13616.36	0.01
5.40				13616.46	13616.46	13616.46	0.00

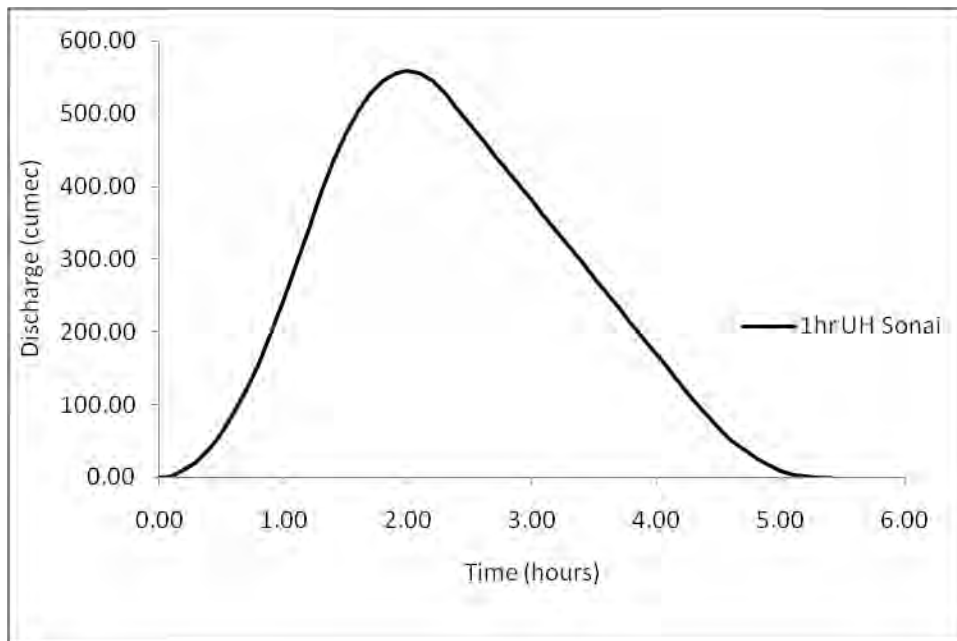

FIGURE 5.45 1hr UH ordinates for Sonai Subbasin

TABLE 5.13 1hr UH ordinates for Katakhal subbasin.

Time (Hours)	GIUH ordinate	GIUH lagged	SUM/2	S-curve addition	S-curve ordinate	lagged by 10x0.1 hr	1hr UH ordinate
0	0.00		0.00		0.00		0.00
0.1	23.86	0.00	11.93	0.00	11.93		1.19
0.2	47.72	23.86	35.79	11.93	47.72		4.77
0.3	71.59	47.72	59.66	47.72	107.38		10.74
0.4	95.45	71.59	83.52	107.38	190.90		19.09
0.5	119.31	95.45	107.38	190.90	298.28		29.83
0.6	143.17	119.31	131.24	298.28	429.52		42.95
0.7	167.04	143.17	155.11	429.52	584.63		58.46

Flood Damage Mitigation: Report

0.8	190.90	167.04	178.97	584.63	763.60		76.36
0.9	214.76	190.90	202.83	763.60	966.43		96.64
1	238.62	214.76	226.69	966.43	1193.12	0.00	119.31
1.1	262.49	238.62	250.56	1193.12	1443.67	11.93	143.17
1.2	286.35	262.49	274.42	1443.67	1718.09	47.72	167.04
1.3	310.21	286.35	298.28	1718.09	2016.37	107.38	190.90
1.4	334.07	310.21	322.14	2016.37	2338.51	190.90	214.76
1.5	357.94	334.07	346.00	2338.51	2684.52	298.28	238.62
1.6	381.80	357.94	369.87	2684.52	3054.39	429.52	262.49
1.7	405.66	381.80	393.73	3054.39	3448.11	584.63	286.35
1.8	429.52	405.66	417.59	3448.11	3865.71	763.60	310.21
1.9	453.39	429.52	441.45	3865.71	4307.16	966.43	334.07
2	477.25	453.39	465.32	4307.16	4772.48	1193.12	357.94
2.1	501.11	477.25	489.18	4772.48	5261.66	1443.67	381.80
2.2	524.97	501.11	513.04	5261.66	5774.70	1718.09	405.66
2.3	548.83	524.97	536.90	5774.70	6311.60	2016.37	429.52
2.4	572.70	548.83	560.77	6311.60	6872.37	2338.51	453.39
2.5	596.56	572.70	584.63	6872.37	7457.00	2684.52	477.25
2.6	620.42	596.56	608.49	7457.00	8065.49	3054.39	501.11
2.7	644.28	620.42	632.35	8065.49	8697.84	3448.11	524.97
2.8	668.15	644.28	656.22	8697.84	9354.05	3865.71	548.83
2.9	692.01	668.15	680.08	9354.05	10034.13	4307.16	572.70
3	715.87	692.01	703.94	10034.13	10738.07	4772.48	596.56
3.1	739.73	715.87	727.80	10738.07	11465.88	5261.66	620.42
3.2	763.60	739.73	751.67	11465.88	12217.54	5774.70	644.28
3.3	752.77	763.60	758.18	12217.54	12975.73	6311.60	666.41
3.4	742.86	752.77	747.81	12975.73	13723.54	6872.37	685.12
3.5	732.94	742.86	737.90	13723.54	14461.44	7457.00	700.44
3.6	723.02	732.94	727.98	14461.44	15189.42	8065.49	712.39
3.7	713.11	723.02	718.07	15189.42	15907.49	8697.84	720.96
3.8	703.19	713.11	708.15	15907.49	16615.64	9354.05	726.16
3.9	693.28	703.19	698.23	16615.64	17313.87	10034.13	727.97
4	683.36	693.28	688.32	17313.87	18002.19	10738.07	726.41
4.1	673.44	683.36	678.40	18002.19	18680.59	11465.88	721.47

Flood Damage Mitigation: Report

4.2	663.53	673.44	668.49	18680.59	19349.08	12217.54	713.15
4.3	653.61	663.53	658.57	19349.08	20007.65	12975.73	703.19
4.4	643.70	653.61	648.65	20007.65	20656.30	13723.54	693.28
4.5	633.78	643.70	638.74	20656.30	21295.04	14461.44	683.36
4.6	623.86	633.78	628.82	21295.04	21923.86	15189.42	673.44
4.7	613.95	623.86	618.91	21923.86	22542.77	15907.49	663.53
4.8	604.03	613.95	608.99	22542.77	23151.76	16615.64	653.61
4.9	594.12	604.03	599.07	23151.76	23750.83	17313.87	643.70
5	584.20	594.12	589.16	23750.83	24339.99	18002.19	633.78
5.1	574.28	584.20	579.24	24339.99	24919.23	18680.59	623.86
5.2	564.37	574.28	569.33	24919.23	25488.56	19349.08	613.95
5.3	554.45	564.37	559.41	25488.56	26047.97	20007.65	604.03
5.4	544.54	554.45	549.49	26047.97	26597.46	20656.30	594.12
5.5	534.62	544.54	539.58	26597.46	27137.04	21295.04	584.20
5.6	524.70	534.62	529.66	27137.04	27666.70	21923.86	574.28
5.7	514.79	524.70	519.75	27666.70	28186.45	22542.77	564.37
5.8	504.87	514.79	509.83	28186.45	28696.28	23151.76	554.45
5.9	494.96	504.87	499.91	28696.28	29196.19	23750.83	544.54
6	485.04	494.96	490.00	29196.19	29686.19	24339.99	534.62
6.1	475.12	485.04	480.08	29686.19	30166.27	24919.23	524.70
6.2	465.21	475.12	470.17	30166.27	30636.44	25488.56	514.79
6.3	455.29	465.21	460.25	30636.44	31096.69	26047.97	504.87
6.4	445.38	455.29	450.33	31096.69	31547.02	26597.46	494.96
6.5	435.46	445.38	440.42	31547.02	31987.44	27137.04	485.04
6.6	425.54	435.46	430.50	31987.44	32417.94	27666.70	475.12
6.7	415.63	425.54	420.59	32417.94	32838.53	28186.45	465.21
6.8	405.71	415.63	410.67	32838.53	33249.20	28696.28	455.29
6.9	395.80	405.71	400.75	33249.20	33649.95	29196.19	445.38
7	385.88	395.80	390.84	33649.95	34040.79	29686.19	435.46
7.1	375.96	385.88	380.92	34040.79	34421.71	30166.27	425.54
7.2	366.05	375.96	371.01	34421.71	34792.72	30636.44	415.63
7.3	356.13	366.05	361.09	34792.72	35153.81	31096.69	405.71
7.4	346.22	356.13	351.17	35153.81	35504.98	31547.02	395.80
7.5	336.30	346.22	341.26	35504.98	35846.24	31987.44	385.88

Flood Damage Mitigation: Report

7.6	326.38	336.30	331.34	35846.24	36177.58	32417.94	375.96
7.7	316.47	326.38	321.43	36177.58	36499.01	32838.53	366.05
7.8	306.55	316.47	311.51	36499.01	36810.52	33249.20	356.13
7.9	296.64	306.55	301.59	36810.52	37112.11	33649.95	346.22
8	286.72	296.64	291.68	37112.11	37403.79	34040.79	336.30
8.1	276.80	286.72	281.76	37403.79	37685.55	34421.71	326.38
8.2	266.89	276.80	271.85	37685.55	37957.40	34792.72	316.47
8.3	256.97	266.89	261.93	37957.40	38219.33	35153.81	306.55
8.4	247.06	256.97	252.01	38219.33	38471.34	35504.98	296.64
8.5	237.14	247.06	242.10	38471.34	38713.44	35846.24	286.72
8.6	227.22	237.14	232.18	38713.44	38945.62	36177.58	276.80
8.7	217.31	227.22	222.27	38945.62	39167.89	36499.01	266.89
8.8	207.39	217.31	212.35	39167.89	39380.24	36810.52	256.97
8.9	197.48	207.39	202.43	39380.24	39582.67	37112.11	247.06
9	187.56	197.48	192.52	39582.67	39775.19	37403.79	237.14
9.1	177.64	187.56	182.60	39775.19	39957.79	37685.55	227.22
9.2	167.73	177.64	172.69	39957.79	40130.48	37957.40	217.31
9.3	157.81	167.73	162.77	40130.48	40293.25	38219.33	207.39
9.4	147.90	157.81	152.85	40293.25	40446.10	38471.34	197.48
9.5	137.98	147.90	142.94	40446.10	40589.04	38713.44	187.56
9.6	128.06	137.98	133.02	40589.04	40722.06	38945.62	177.64
9.7	118.15	128.06	123.11	40722.06	40845.17	39167.89	167.73
9.8	108.23	118.15	113.19	40845.17	40958.36	39380.24	157.81
9.9	98.32	108.23	103.27	40958.36	41061.63	39582.67	147.90
10	88.40	98.32	93.36	41061.63	41154.99	39775.19	137.98
10.1	78.48	88.40	83.44	41154.99	41238.43	39957.79	128.06
10.2	68.57	78.48	73.53	41238.43	41311.96	40130.48	118.15
10.3	58.65	68.57	63.61	41311.96	41375.57	40293.25	108.23
10.4	48.74	58.65	53.69	41375.57	41429.26	40446.10	98.32
10.5	38.82	48.74	43.78	41429.26	41473.04	40589.04	88.40
10.6	28.90	38.82	33.86	41473.04	41506.90	40722.06	78.48
10.7	18.99	28.90	23.95	41506.90	41530.85	40845.17	68.57
10.8	9.07	18.99	14.03	41530.85	41544.88	40958.36	58.65
10.9	0.00	9.07	4.54	41544.88	41549.41	41061.63	48.78

11		0.00	0.00	41549.41	41549.41	41154.99	39.44
11.1				41549.41	41549.41	41238.43	31.10
11.2				41549.41	41549.41	41311.96	23.75
11.3				41549.41	41549.41	41375.57	17.38
11.4				41549.41	41549.41	41429.26	12.02
11.5				41549.41	41549.41	41473.04	7.64
11.6				41549.41	41549.41	41506.90	4.25
11.7				41549.41	41549.41	41530.85	1.86
11.8				41549.41	41549.41	41544.88	0.45
11.9				41549.41	41549.41	41549.41	0.00
12				41549.41	41549.41	41549.41	0.00

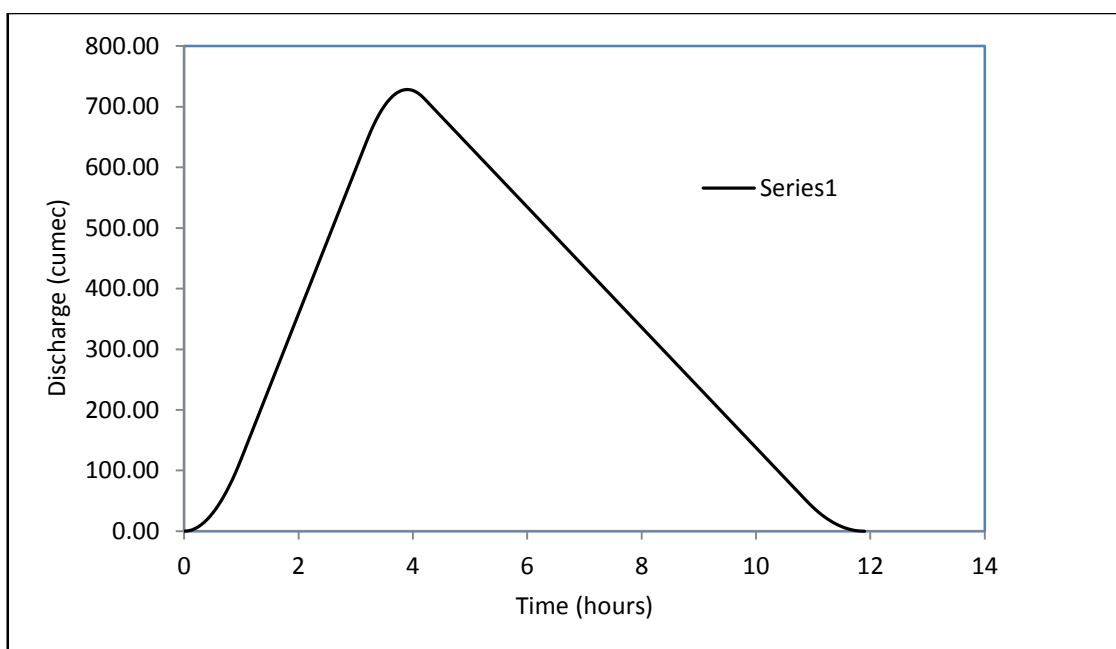

FIGURE 5.46 1hr UH ordinates for Katakhal sub-basin

6.0 Stage-Discharge Relationship for River Sections:

Hourly river stage data during monsoon period for various gauging sections in Barak Valley are used in the study to develop flow simulation model for the river system. A stage discharge relationship for the gauging stations have been developed using nonlinear regression technique. The stage –discharge relationships developed for different gauging stations in the valley are as follows:

TABLE 6.1 Stage-Discharge Relationships for various gauging stations:

Name of the River	Gauging Station	Depth vs Discharge Relationships
Barak	Fulertal	$Q = 0.5038y^{3.4265}$
Rukni	Dholai	$Q = 0.5362y^{3.1835}$
Sonai	TulerGram	$Q = 0.7115y^{2.5212}$
Sonai	Moinerkhal	$Q = 6.6468 y^{2.1154}$
Barak	Annapunaghat	$Q = 0.8780y^{3.0115}$
Katakhal	Matijuri	$Q = 0.0571y^{3.9116}$
Barak	Badarpurghat	$Q = 0.5823y^{3.248}$
Gumra	Ghumra	$Q = 7.1989 y^{1.7705}$
Longai	Fakirabazar	$Q = 0.1317 y^{3.2366}$

6.1 River System Flood Flow Simulation Model:

The three districts in Bark Valley are drained by the Barak River system; flow in the main river is due to flows from different upstream catchments. In the study area Flows from the upstream catchments unite downstream forming a combined outflow for the river system. A river system having a number of upstream flows may be replaced by an imaginary single channel having a single upstream flow that produces same outflow as observed in the river system (Choudhury 2002,2007). The multiple inflows-single outflow model for the river systems have been calibrated by using computed discharge data for the river system. As described earlier, the drainage system in the study area is segmented into networks with outflow at Annapurnaghat and at Badarpurghat. Stage data for all gauging stations in the study were collected from CWC office and the hourly rainfall data for the stations in the study area were collected from RMC Guwahati. Considering maximum availability of rainfall records the flow data for the downstream station at Badarpurghat is scanned to identify

major flood events. Three flood events during the period 2000-2010 were selected considering availability of rainfall records. Details of the flood events used in the study are given in the table below.

TABLE 6.2 Details of the flood Events used in the study

<i>Details Of flood Events Considered</i>																	
Flood Events	Start		End		Peak Flow Depth		Peak Flow Rate		Safe Depth		Safe Discharge		Rainfall Duration		Total Rainfall duration in (h)		
	Date	Time	Date	Time	A.P.Ghat	B.P.Ghat	A.P.Ghat	B.P.Ghat	A.P.Ghat	B.P.Ghat	A.P.Ghat	B.P.Ghat	Start				
	Date	Time	Date	Time	A.P.Ghat	B.P.Ghat	A.P.Ghat	B.P.Ghat	A.P.Ghat	B.P.Ghat	A.P.Ghat	B.P.Ghat	Date	Time		Date	Time
Event-1	10-Jul-04	1:00AM	17-Jul-04	12:00AM	16.36	15.93	4048.63	4859.993	20.39	17.20	3300.902	4015	8-Jul-04	1:00AM	19-Jul-04	12:00AM	264
Event-2	19-Jul-04	1:00AM	29-Jul-04	12:00AM	16.69	16.26	4398.26	4870.75	20.39	17.20	3300.902	4015	17-Jul-04	1:00AM	1-Aug-04	12:00AM	336
Event-3	11-Jun-06	1:00AM	21-Jun-06	12:00AM	15.70	15.68	3718.74	4759.86	20.39	17.20	3300.902	4015	9-Jul-04	1:00AM	22-Jul-04	12:00AM	312

Using the recorded for the gauged catchments and computed flow for the ungauged catchment downstream flow at Annapurnaghat and Badarpurghat are simulated on the basis of upstream flows applying the model as given in equation (6.1)

$$Q_{(t+\Delta t)}^D = C_1(\sigma^{1,r} Q_t^1 + \sigma^{2,r} Q_t^2 + \sigma^{3,r} Q_t^{3,r} + \dots \sigma^{n,r} Q_t^{n,r}) + C_2(\sigma^{1,r} Q_t^1 + \sigma^{2,r} Q_t^2 + \sigma^{3,r} Q_t^{3,r} + \dots \sigma^{n,r} Q_t^{n,r}) + C_3 Q_t^d \tag{6.1}$$

Here, $Q_{(*)}^{(*)}$ = flow from the upstream catchments and $Q_{(*)}^D$ = flow at the downstream station in the river system. Model parameters for the upper and complete networks were estimated by using genetic algorithm techniques.

Model parameters estimation:

The model parameters C_1 , C_2 , C_3 or k & x and $\sigma^{p,r}$ are estimated by minimizing the objective function given by-

$$\text{Min } f = (Q_{\text{comp}} - Q_{\text{obs}})^2 \quad (6.2)$$

Here, Q_{comp} = computed downstream discharge and Q_{obs} = Observed downstream discharge

Upper Network with outflow at Annapurnaghat:

The upper network consists of flows from both gauged and ungauged catchments; there are six upstream flow stations in the river network with outflow at Annapurnaghat. As there are six upstream stations in the river network to calibrate the simulation model parameters C_1 , C_2 , and the shift parameters, $\sigma^{1,r}$ for six upstream flows are estimated using a recorded flood event. In the present study three flood events are used that occurred during the period 2000-2010. The periods of the selected flood events, event-1, event-2 and event-3 are: July 10-17, 2004; July 19-29, 2004 and June 11-21, 2006. The duration of the events are 168hrs, 240hrs and 240hrs respectively. The flood events used in the study are shown in figures: Discharge data of event (1) are used to estimate the model parameters by minimizing the sum of squared error between observed and computed outflow at Annapurnaghat. The estimated model parameters for the upper network are given in the table below.

Complete River Network with outflow at Badarpurghat:

To simulate the flow at Badarpurghat complete river network in the study area is considered. The complete river network consists of nine upstream flows and the downstream outflow is at Badarpurghat. The upstream flows in the river systems are: from the catchments of Jiri, Chiri, Madhura, Ghagra, Jatinga and the river flows recorded at Fulertal, Dholai, Moinerkhal, and Matijuri. Using the same flood event (event-1) model parameters for the complete network are also estimated by using genetic algorithm technique. The estimated parameters for the networks are listed in the Tables given below:

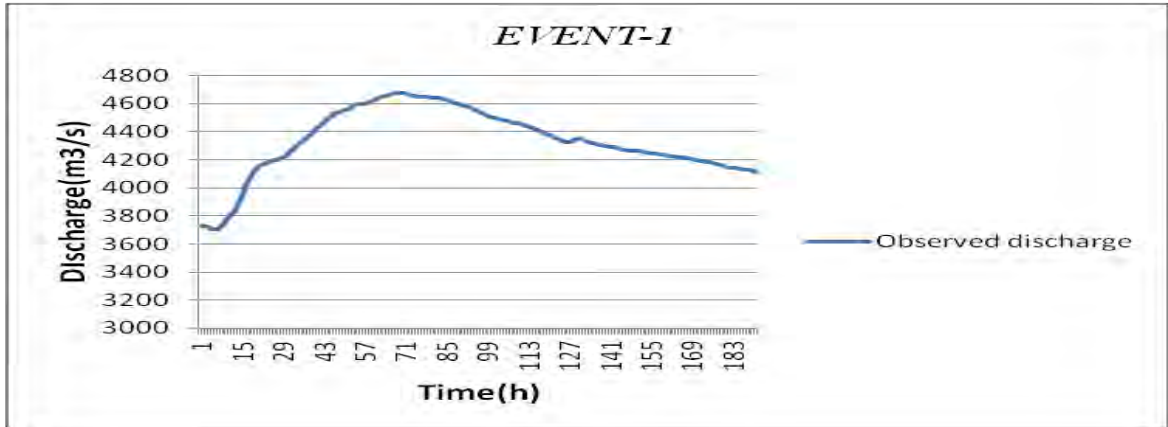

FIGURE 6.1 represents the flood event from 10th – 17th July, 2004 at BpGhat.

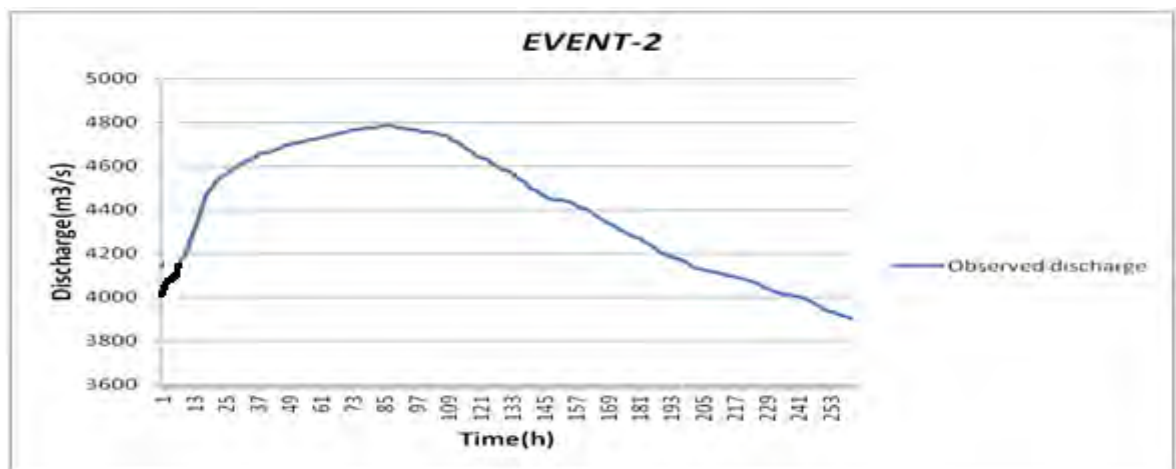

FIGURE 6.2 Represents the flood event from 19th – 29th July, 2004 at BpGhat

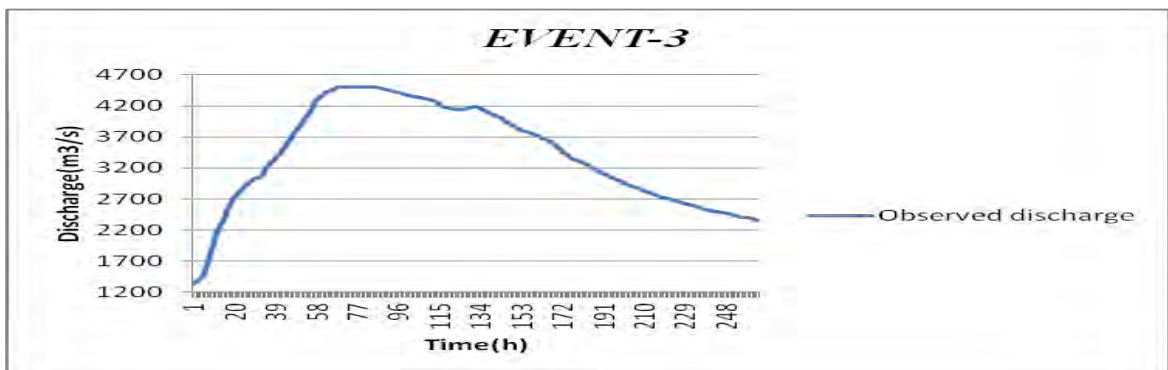

FIGURE 6.3 The flood event from 11th – 21st June, 2006 at BpGhat.

TABLE 6.3 Estimated parameter for the upper network having outflow at Annapurnaghat

<i>UPPERNETWORK-Jiri-Fulertal-Chiri-Dholai-Maniarkhal-Madhura-A.P.ghat</i>										
σ^1 (Jiri)	σ^2 (Fulertal)	σ^3 (Chiri)	σ^4 (Dholai)	σ^5 (Mani)	σ^6 (Madhura)	C_1	C_2	C_3 (A.P. Ghat)	K (hrs)	x
0.61	0.71	0.21	1.00	0.57	0.28	0.10	0.11	.80	5	0.1

TABLE 6.4 Estimated parameter for the complete River Network having outflow at Badarpurghat

<i>Complete Network:Rivers:Jiri-Fulertal-Chiri-Dholai-Maniarkhal-Madhura-Jatinga-Matijuri-Ghagra-Badarpurghat</i>													
σ^1 (Jiri)	σ^2 (Fulertal)	σ^3 (Chiri)	σ^4 (Dholai)	σ^5 (Mani)	σ^6 (Madhu)	σ^7 (Jatinga)	σ^8 (Matijuri)	σ^9 (Ghagra)	C_1	C_2	C_3	k (hrs)	x
0.10	0.31	0.21	0.72	0.10	0.20	0.13	2.19	0.10	0.09	0.05	0.85	7.0	0.02

Using the estimated parameters in the multiple flow model given by equation (6.1) flood flow at Annapurnaghat and at Badarpurghat are estimated for the flood events as shown in the figures 6.4 to figure 6.9

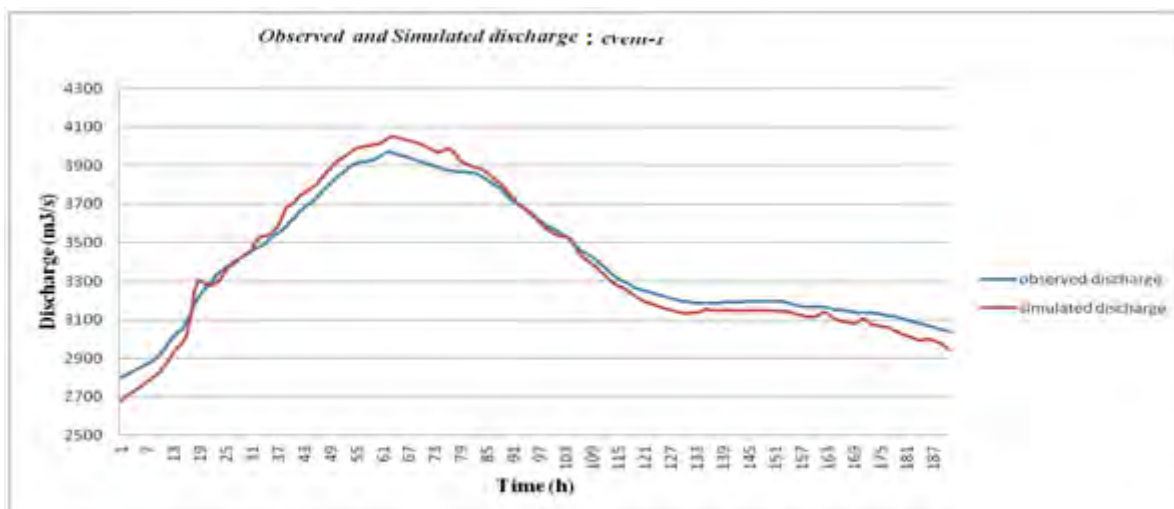

FIGURE 6.4 Observed and simulated discharge at Annapurnaghat (event-1)

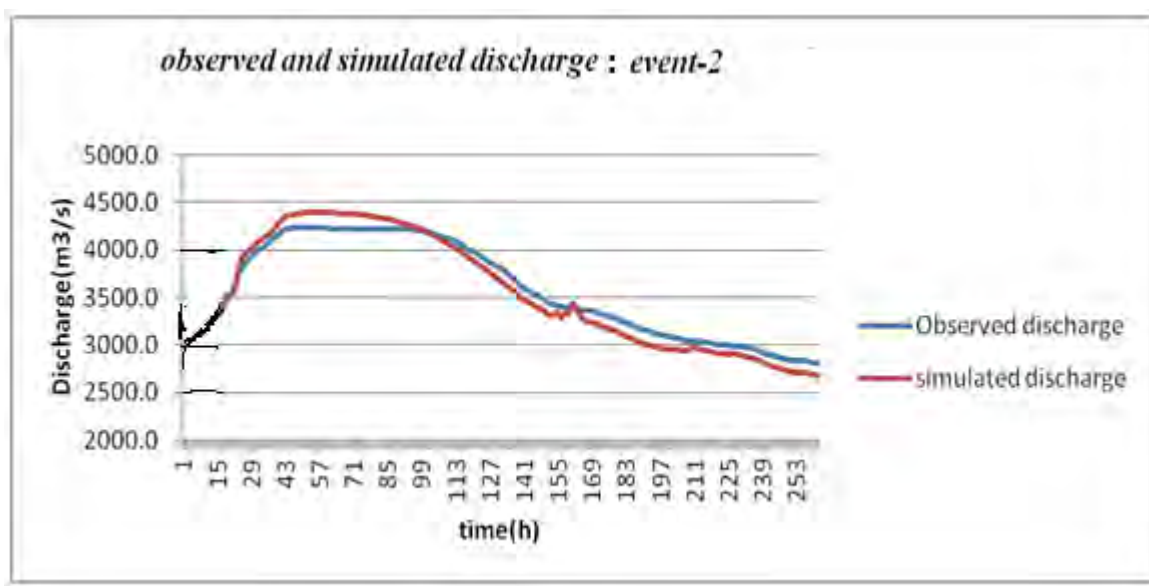

FIGURE 6.5 Observed and simulated discharge at Annapurnaghat (event-2)

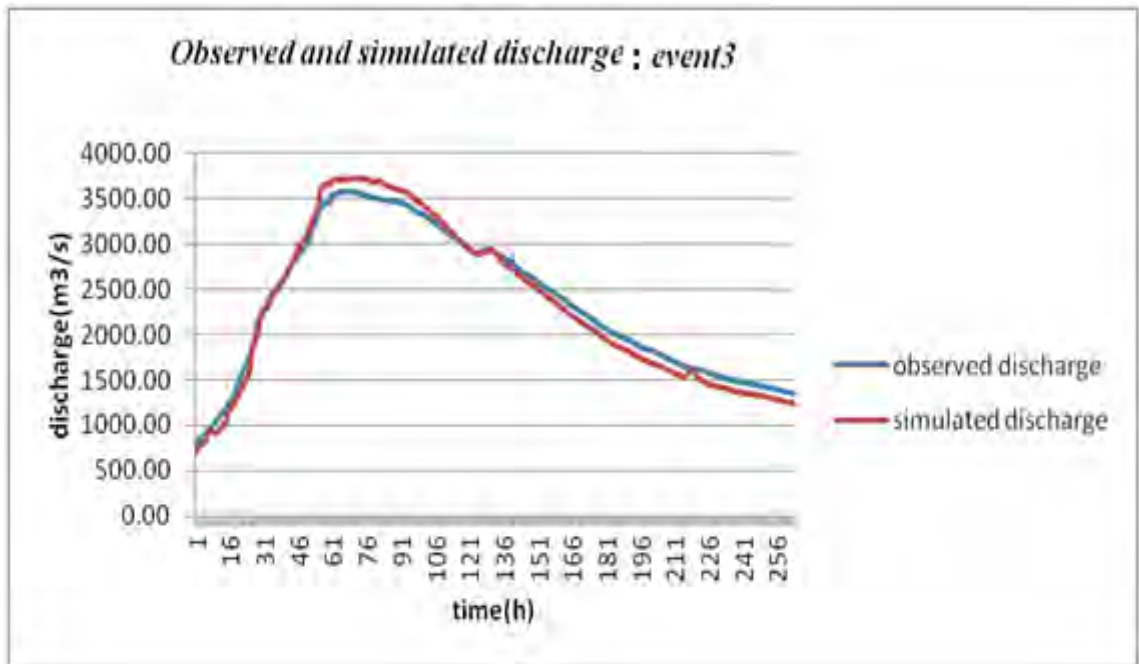

FIGURE 6.6 Observed and simulated discharge at Annapurnaghat (event-3)

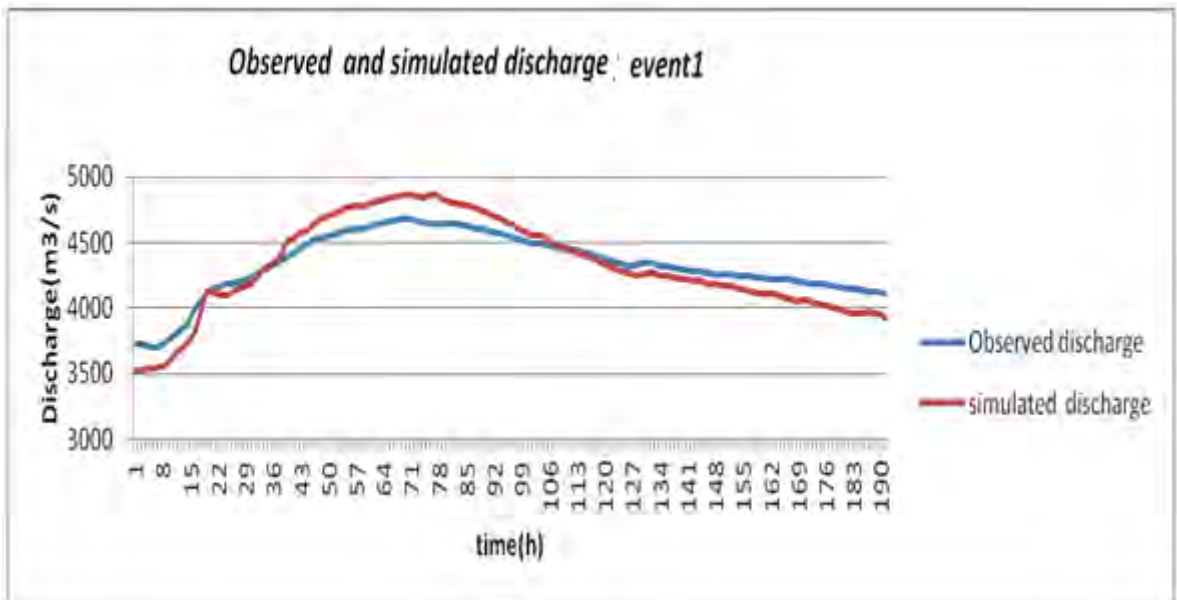

FIGURE 6.7 Observed and simulated discharge at Badrpurghat (event-1)

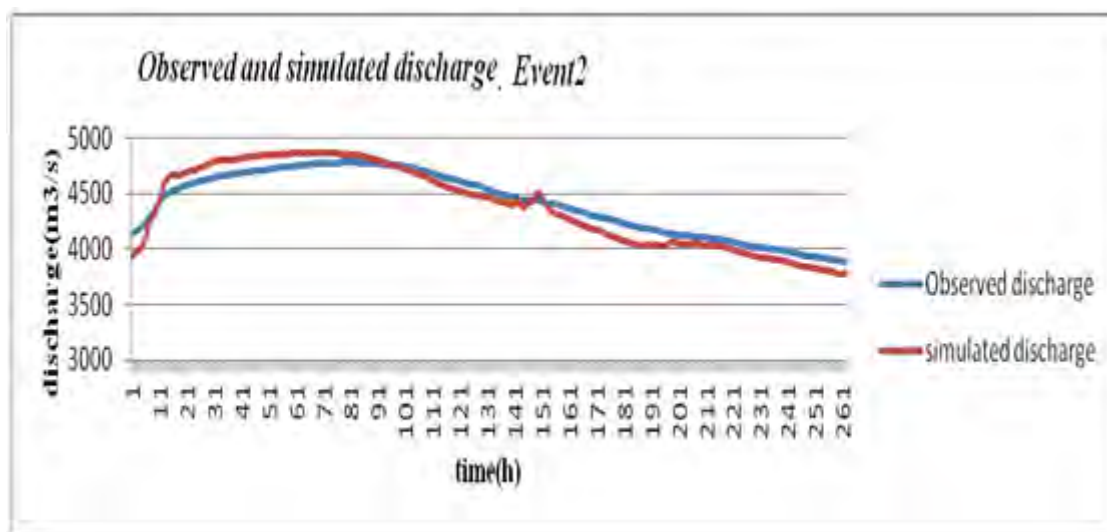

FIGURE 6.8 Observed and simulated discharge at Badrpurghat (event-2)

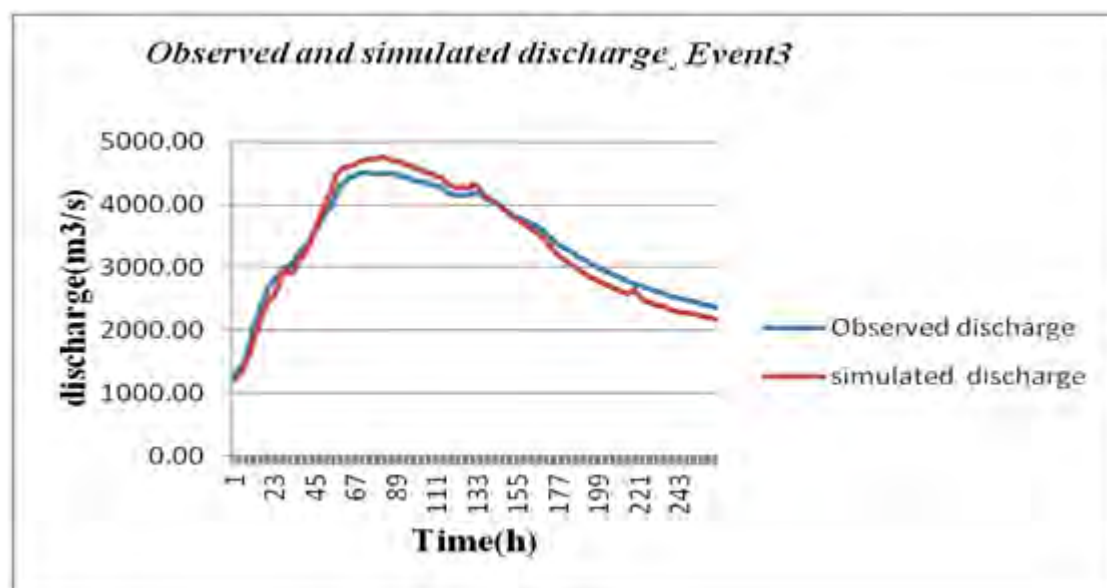

FIGURE 6.9 Observed and simulated discharge at Badrpurghat (event-3)

6.2 Downstream Flood Peak Improvement Analysis:

The simulation model given by equation (6.1) is further used to estimate impacts of tributary flows on the downstream flood flow scenarios. Applying flow simulation model the peak flow reduction indicating improvement in the flood flow at the downstream stations Annapurnaghat and Badarpurghat for completely restricting flows from the ungauged and gauged catchments is studied. The simulation study is conducted by restricting flow in one catchment at a time and restricting flow from two catchments at a time. The results obtained in terms of percentage reduction in the peak flow rate at the downstream station Annapurnaghat and Badarpurghat for event-1 and the average improvement considering selected three events are listed in Tables- 6.5 to 6.12 given in the following pages.

TABLE 6.5 Peak flow improvement at Annapurnaghat for restricting flow from single upstream catchment completely (EVENT 1: FROM 10-JULY TO 17 JULY-2004)

Sl. Nol	Flow restricted in	Peak Discharge- A.P.Ghat(Obs)	Peak Discharge (With Restricted Flow)	Safe Discharge	D/S Unsafe Discharge Reduction				Flooding Time				Peak Discharge			
					Volume(above safe level m ³)	Volume(above safe level (Rest)	Improvement (m ³)	%improvement	Total flood time (Hours)	Reduced flood time (Hours)	Improvement (Hours)	%improvement	Obs.Peak Discharge above danger level (m ³ /s)	Restricted Peak Discharge above safe level (m ³ /s)	Improvement(m ³ /s)	%improvement
1	JIRI	4049	4046	3301	2691828	2680612	11215	0.41	90	90	0	0	748	745	3.11	0.417
2	CHIRI	4049	4041	3301	2691828	2662751	29076	1.08	90	90	0	0	748	740	8.07	1.08
3	DHOLAI	4049	4011	3301	2691828	2555138	136689	5.07	90	87	3	3.33	748	710	37.96	5.078
4	MANIARKHAL	4049	3983	3301	2691828	2457242	234585	8.71	90	87	3	3.33	748	683	65.16	8.715
5	MADHURA	4049	4040	3301	2691828	2659861	31967	1.18	90	90	0	0	748	739	8.88	1.188

TABLE 6.6 Peak flow improvement at Annapurnaghat for restricting flow from two upstream catchments completely (EVENT 1: FROM 10-JULY TO 17 JULY-2004)

Sl. Nol	Flow restricted in	Peak Discharge- A.P.Ghat(Obs)	Peak Discharge (With Restricted Flow)	Safe Discharge	D/S Unsafe flow Reduction				Flooding Time				Flood Peak Discharge			
					Volume(above safe level m ³)	Volume(above safe level (Rest)	Improvement (m ³)	%improvement	Total flood time (Hours)	Reduced flood time (Hours)	Improvement (Hours)	%improvement	ObsPeak Discharge above danger level (m ³ /s)	Restricted Peak Discharge above safe level (m ³ /s)	Improvement(m ³ /s)	%improvement
1	Jiri& chi	4049	4037	3301	2691828	2651536	40292	1.497	90	90	0	0	748	737	11	1.497
2	Jiri &dho	4049	4008	3301	2691828	2543923	147904	5.495	90	87	3	3.333	748	707	41	5.495
3	Jiri &mani	4049	3980	3301	2691828	2446027	245800	9.131	90	87	3	3.333	748	679	68	9.131
4	Jiri & mad	4049	4037	3301	2691828	2648646	43182	1.604	90	88	2	2.222	748	736	12	1.604
5	chi &dho	4049	4003	3301	2691828	2526062	165766	6.158	90	86	4	4.444	748	702	46	6.158
6	Chi&man	4049	3975	3301	2691828	2428166	263662	9.795	90	87	3	3.333	748	674	73	9.795
7	Chi&mad	4049	4032	3301	2691828	2630785	61043	2.268	90	88	2	2.222	748	731	17	2.268
8	Dho&ma	4049	3946	3301	2691828	2320554	371274	13.79	90	84	6	6.667	748	645	103	13.79
9	Dho&mad	4049	4002	3301	2691828	2523172	168656	6.265	90	86	4	4.444	748	701	47	6.265
10	Man&mad	4049	3975	3301	2691828	2425276	266552	9.902	90	86	4	4.444	748	674	74	9.902

TABLE 6.7 Peak flow improvement at BadarpurGhat for restricting flow from single upstream catchment completely (EVENT 1: FROM 10-JULY TO 17 JULY-2004)

Sl. Nol	Flow restricted in	Peak Discharge- B.P.Ghat(Obs)	Peak Discharge (With Restricted Flow)	Safe Discharge	D/S Unsafe flow Reduction				Flooding Time				Flood Peak Discharge			
					Volume(above safe level m ³)	Volume(above safe level (Rest)	Improvement (m ³)	%improvement	Total flood time (Hours)	Reduced flood time (Hours)	Improvement (Hours)	%improvement	ObsPeak.Discharge above danger level (m ³ /s)	Restrict ObsPeak Discharge above safe level (m ³ /s)	Improvement(m ³ /s)	%improvement
1	Jiri	4860	4857	4015	3041973	3030198	11776	0.38	160	156	4	2.5	845	842	3	0.387
2	Chiri	4860	4854	4015	3041973	3020657	21316	0.70	160	156	4	2.5	845	839	6	0.701
3	Dholai	4860	4841	4015	3041973	2973934	68039	2.23	160	157	3	1.875	845	826	19	2.237
4	Moniar	4860	4852	4015	3041973	3012209	29764	0.97	160	158	2	1.25	845	837	8	0.978
5	Madhu	4860	4855	4015	3041973	3024992	16981	0.55	160	156	4	2.5	845	840	5	0.558
6	Jatinga	4860	4857	4015	3041973	3031787	10186	0.33	160	157	3	1.875	845	842	3	0.335
7	Matijhu	4860	4295	4015	3041973	1009705	2032268	66.80	160	76	84	52.5	845	280	565	66.808
8	Ghagra	4860	4858	4015	3041973	3036250	5723	0.188	160	158	2	1.25	845	843	2	0.188

Sl. No1	Flow restricted in	Peak Discharge- B.P.Ghat(Obs)	Peak Discharge (With Restricted Flow)	Safe Discharge	D/S Unsafe Discharge Reduction				Flooding Time				Flood Peak Discharge			
					Volume(above safe level m ³)	Volume(above safe level (Rest)	Improvement (m ³)	%improvement	Total flood time (Hours)	Reduced flood time (Hours)	Improvement (Hours)	%improvement	Obs. Peak Discharge above danger level (m ³ /s)	Restricted Peak Discharge above safe level (m ³ /s)	Improvement(m ³ /s)	%improvement
1	Jiri and Chiri	4860	4851	4015	3041973	3008881	33092	1.09	160	155	5	3.1	844	835.80	9.2	1.1
2	Jiri and Dholai	4860	4838	4015	3041973	2962158	79815	2.62	160	154	6	3.8	844	822.82	22.2	2.6
3	Jiri and Moniarkhal	4860	4848	4015	3041973	3000434	41539	1.37	160	156	4	2.5	844	833.45	11.5	1.4
4	Jiri and Madhura	4860	4852	4015	3041973	3013216	28757	0.95	160	156	4	2.5	844	837.01	8.0	0.9
5	Chiri and Dholai	4860	4835	4015	3041973	2952618	89356	2.94	160	155	5	3.1	844	820.17	24.8	2.9
6	Chiri and Moniarkhal	4860	4846	4015	3041973	2990893	51080	1.68	160	156	4	2.5	844	830.80	14.2	1.7
7	Chiri and Madhura	4860	4849	4015	3041973	3003676	38298	1.26	160	156	4	2.5	844	834.35	10.6	1.3
8	Dholai and Moniarkhal	4860	4833	4015	3041973	2944170	97803	3.22	160	156	4	2.5	844	817.83	27.2	3.2
9	Dholai and Madhura	4860	4836	4015	3041973	2956953	85020	2.80	160	155	5	3.1	844	821.38	23.6	2.8
10	Moniarkhal and Madhura	4860	4847	4015	3041973	2995228	46745	1.54	160	156	4	2.5	844	832.01	13.0	1.5
11	Jatinga and Matijhuri	4860	4293	4015	3041973	999519	2042454	67.14	160	76	84	52.5	844	277.64	567.3	67.1
12	Jatinga and Ghagra	4860	4856	4015	3041973	3026064	15909	0.52	160	156	4	2.5	844	840.57	4.4	0.5
13	Matijhuri and Ghagra	4860	4294	4015	3041973	1003982	2037991	67.00	160	76	84	52.5	844	278.88	566.1	67.0

Average Improvements in the downstream flood flow in terms of reduction in peak flow rates at Annapurnaghat and Badarpurghat considering flood events-1,2 and 3 are computed and are as given in the following tables 6.9-6.12

TABLE 6.9 Peak flow improvement (Average) at Annapurnaghat for restricting flow from single upstream catchment completely

Flow restricted in	Peak Discharge- A.P.Ghat(Obs)	Peak Discharge (With Restricted Flow)	Safe Discharge	D/S Unsafe Discharge Reduction				Flooding Time				Peak Discharge			
				Volume(above safe level m ³)	Volume(above safe level (Rest)	Improvement (m ³)	Av. %improvement	Total flood time (Hours)	Reduced flood time (Hours)	Improvement (Hours)	%improvement	Obs.Peak Discharge above danger level (m ³ /s)	Restricted Peak Discharge above safe level (m ³ /s)	Improvement(m ³ /s)	Av. %improvement
JIRI	4049	4046	3301	2691828	2680613	11215	0.49	90	90	0	0.00	748	745	3	0.49
CHIRI	4049	4041	3301	2691828	2662751	29076	1.25	90	90	0	0.00	748	740	8	1.25
DHOLAI	4049	4011	3301	2691828	2555139	136689	11.83	90	87	3	3.33	748	710	38	11.83
MANIARKHAL	4049	3983	3301	2691828	2457243	234585	10.43	90	87	3	3.33	748	683	65	10.43
MADHURA	4049	4040	3301	2691828	2659861	31967	1.61	90	90	0	0.00	748	739	9	1.61

TABLE 6.10 Peak flow improvement (Average) at Annpurnaghat for restricting flow from two upstream catchment completely)

Flow restricted in	Peak Discharge- A.P.Ghat(Obs)	Peak Discharge (With Restricted Flow)	Safe Discharge	D/S Unsafe Discharge Reduction				Flooding Time				Flood Peak Discharge			
				Volume(above safe level m ³)	Volume(above safe level (Rest)	Improvement (m ³)	Av. %improvement	Total flood time (Hours)	Reduced flood time (Hours)	Improvement (Hours)	%improvement	Obs.Peak Discharge above danger level (m ³ /s)	Restricted Peak Discharge above safe level (m ³ /s)	Improvement(m ³ /s)	Av. %improvement
Jiri & chi	4049	4037	3300.9	2691827	2651536	40292	1.735	90	90	0	0	747.73	737	11.192	1.735
Jir & dho	4049	4008	3300.9	2691827	2543923	147904	12.316	90	87	3	3.333	747.73	707	41.085	12.316
Jir & mani	4049	3980	3300.9	2691827	2446027	245800	10.91	90	87	3	3.333	747.73	679	68.278	10.91
Jir & madhu	4049	4037	3300.9	2691827	2648645	43182	1.858	90	88	2	2.222	747.73	736	11.995	1.858
chi & dho	4049	4003	3300.9	2691827	2526062	165765	13.034	90	86	4	4.444	747.73	702	46.046	13.034
Chi & mani	4049	3975	3300.9	2691827	2428166	263661	11.676	90	87	3	3.333	747.73	674	73.239	11.676
Chi & madhu	4049	4032	3300.9	2691828	2630785	61043	2.624	90	88	2	2.222	747.73	731	16.956	2.624
Dho & mani	4049	3946	3300.9	2691828	2320554	371274	22.256	90	84	6	6.667	747.73	645	103.132	22.256
Dho & madhu	4049	4002	3300.9	2691828	2523172	168656	13.204	90	86	4	4.444	747.73	701	46.849	13.204
Mani & madhu	4049	3975	3300.9	2691828	2425276	266552	11.799	90	86	4	4.444	747.73	674	74.042	11.799

TABLE 6.11 Peak flow improvement (Average) at BadarpurGhat for restricting flow from single upstream catchment completely

Flow restricted in	Peak Discharge- B.P. Ghat(Obs)	Peak Discharge (With Restricted Flow)	Safe Discharge	D/S Unsafe Discharge Reduction				Flooding Time				Flood Peak Discharge			
				Volume(above safe level m ³)	Volume(above safe level (Rest)	Improvement (m ³)	Av. %improvement	Total flood time (Hours)	Reduced flood time (Hours)	Improvement (Hours)	%improvement	Peak Discharge above danger level (m ³ /s)	Restricted Peak Discharge above safe level (m ³ /s)	Improvement(m ³ /s)	Av. %improvement
Jiri	4860	4857	4015	3041973	3030198	11776	2.15	160	156	4	3	845	842	3.27	2.05
Chiri	4860	4854	4015	3041973	3020657	21316	1.33	160	156	4	3	845	839	5.92	1.36
Dholai	4860	4841	4015	3041973	2973934	68039	4.14	160	157	3	2	845	826	18.90	4.14
Moniar	4860	4852	4015	3041973	3012209	29764	1.14	160	158	2	1	845	837	8.27	1.04
Madhu	4860	4855	4015	3041973	3024992	16981	1.10	160	156	4	3	845	840	4.72	1.50
Jatinga	4860	4857	4015	3041973	3031787	10186	0.70	160	157	3	2	845	842	2.83	0.70
Matijhuri	4860	4295	4015	3041973	1009705	2032268	66.15	160	76	84	53	845	280	564.52	6.15
Ghagra	4860	4858	4015	3041973	3036250	5723	0.39	160	158	2	1	845	843	1.59	1.39

TABLE 6.12 Peak flow improvement (Average) at BadarpurGhat for restricting flow from two upstream catchment

Flow restricted in	Peak Discharge- B.P.Ghat(Obs)	Peak Discharge (With Restricted Flow)	Safe Discharge	D/S Unsafe Discharge Reduction				Flooding Time				Flood Peak Discharge			
				Volume(above safe level m ³)	Volume(above safe level (Rest)	Improvement (m ³)	Av. %improvement	Total flood time (Hours)	Reduced flood time (Hours)	Improvement (Hours)	%improvement	Peak Discharge above danger level (m ³ /s)	Restricted Peak Discharge above safe level (m ³ /s)	Improvement(m ³ /s)	Av. %improvement
Jiri and Chiri	4860	4851	4015	3041973	3008881	33092	1.7	160	155	5	3.1	845	836	9	1.7
Jiri and Dholai	4860	4838	4015	3041973	2962158	79815	3.6	160	154	6	3.8	845	823	22	3.6
Jiri and Moniarkhal	4860	4848	4015	3041973	3000434	41539	2.8	160	156	4	2.5	845	833	12	2.8
Jiri and Madhura	4860	4852	4015	3041973	3013216	28757	2.1	160	156	4	2.5	845	837	8	2.1
Chiri and Dholai	4860	4835	4015	3041973	2952618	89356	4.1	160	155	5	3.1	845	820	25	4.1
Chiri and Moniarkhal	4860	4846	4015	3041973	2990893	51080	3.4	160	156	4	2.5	845	831	14	3.4
Chiri and Madhura	4860	4849	4015	3041973	3003676	38298	2.7	160	156	4	2.5	845	834	11	2.7
Dholai and Moniarkhal	4860	4833	4015	3041973	2944170	97803	-1.3	160	156	4	2.5	845	818	27	-1.3
Dholai and Madhura	4860	4836	4015	3041973	2956953	85020	5.1	160	155	5	3.1	845	821	24	5.1
Moniarkhal and Madhura	4860	4847	4015	3041973	2995228	46745	3.2	160	156	4	2.5	845	832	13	3.2
Jatinga and Matijhuri	4860	4293	4015	3041973	999519	2042454	49.0	160	76	84	52.5	845	278	567	49.0
Jatinga and Ghagra	4860	4856	4015	3041973	3026064	15909	19.1	160	156	4	2.5	845	841	4	19.1
Matijhuri and Ghagra	4860	4294	4015	3041973	1003982	2037991	48.3	160	76	84	52.5	845	279	566	48.3

Results given in Tables 6.9 through 6.12 shows that the flow from Jiri catchment has the least effect on the downstream flow at Annapurnaghat while impacts of flow from the catchment of Dholai on the flow at Annapuraghat is the highest. Similar results is obtained when flows from two catchments are restricted and it is found that when flow from Dholai and Mainerkhal are restricted it results to maximum reduction in the peak flood flow rate at Annapurnaghat. In the case of Badarpurghat flow from the catchment of Matijuri is found to have maximum impact and flow from the catchment of Mainerkhal has the least impact on the flood flow at Badarpurghat. Again it is seen that when flow from Matijuri and Jatinga or Matijuri and Ghagra are simultaneously restricted maximum reduction in the peak flood flow rate at Badarpurghat is obtained.

6.3 Linear Programming (LP) Formulation

Linear Programming models for finding the maximum flow rates for a number of upstream catchments to have desired flow levels, below danger level at the downstream points are formulated for the upper network with outflow at Annapurnaghat and for the complete network having outflow at Badarpurghat. The model are run for the normal conditions as well as considering effects on discharge rate due to change in the climate in this region. A separate report on assessment of effects of climate change on flows and rainfalls in the region due to change in the climate conducted by IIT Guwahati is appended with this report. The mathematical program is written in standard LP form with all known quantities on the right hand side of the constraints.

$$\text{Maximize } Z = \sum_{t=1}^{T+1} \text{Flow at upstream stations} \quad (6.3)$$

Subject to the flow constraint applicable to a river system:

$$c_1\sigma_1 i_t^1 + c_2\sigma_1 i_{t+1}^1 + c_1\sigma_3 i_t^3 + c_2\sigma_3 i_{t+1}^3 + c_1\sigma_4 i_t^4 + c_2\sigma_4 i_{t+1}^4 + c_1\sigma_5 i_t^5 + c_2\sigma_5 i_{t+1}^5 + c_1\sigma_6 i_t^6 + c_2\sigma_6 i_{t+1}^6 + c_3 q_t = q_{t+1} - c_1\sigma_2 i_t^2 + c_2\sigma_2 i_{t+1}^2 \quad (6.4)$$

and safe flow limits at the downstream stations.

$$q_{t+1} \leq \text{SafeFlow}$$

$$q_t \leq q_{max} ; t = 1, 2, \dots, T+1$$

Where, c_1, c_2, c_3 are the routing model coefficient.

$\sigma_1, \sigma_2, \dots, \sigma_6$ are the shift factor.

q_{t+1} is the discharge at downstream at time (t+1).

The values of the parameters in equation (6.4) are obtained from the simulation model described earlier. The model is run to maximize flows from a set of upstream catchments with the constraints that the flow at the downstream stations are less than safe flow rates at the corresponding section. The model has been formulated to determine safe flow condition for the downstream locations Annapurnaghat and Badarpurghat in the river system.

6.4 Data used

3 Flood Events used in the study,

Event 1- July 10-17, 2004

Event 2- July 19- 29, 2004

Event 3- June 11- 21, 2006

TABLE 6.13 Flood events used in the study

Flood Events Details													
Flood Events	Start		End		Peak Flow Depth		Peak Flow Rate		Safe Depth		Safe Discharge		
	Date	Time	Date	Time	A.P.Ghat	B.P.Ghat	A.P.Ghat	B.P.Ghat	A.P.Ghat	B.P.Ghat	A.P.Ghat	B.P.Ghat	
Event-1	10-Jul-04	1:00AM	17-Jul-04	12:00AM	16.36	15.93	4048.63	4859.993	20.39	17.2	3300.902	4015	
Event-2	19-Jul-04	1:00AM	29-Jul-04	12:00AM	16.69	16.26	4398.26	4870.75	20.39	17.2	3300.902	4015	
Event-3	11-Jun-06	1:00AM	21-Jun-06	12:00AM	15.7	15.68	3718.74	4759.86	20.39	17.2	3300.902	4015	

6.5 LP Model Results

The simulation models described earlier and the LP model formulated for the river system are run for various upstream conditions to assess impacts of flood flow at the downstream locations due to changes in the flow conditions at the upstream catchments. The different cases considered in the study and the results obtained are presented below. The model is used to estimate a set of maximum possible peak flow rates for the upstream catchment that creates safe flow at the important D/S locations in the river system. The models is run for two cases, (i) major ungauged catchments are regulated and (ii) major U/S gauged and ungauged catchment flow excepting the main channel flow at Fulertal are controlled.

Case-1: Restricted flows from all upstream ungauged Catchments

The study is conducted to evaluate maximum allowable peak flow rates from the unaguged catchments resulting minimum possible (safe flow) at the downstream station with no regulation of flow in the gauged catchments. In this case the downstream flow rates are constrained to be less than the safe flow at the downstream station and maximum possible peak flow rates in the upstream ungauged catchments considering event-1, event-2 and event-3 are determined applying the LP model. The peak flow rates obtained for the three events are averaged for the catchments to compute maximum possible Peak flow rates from these catchments that produce safe flow at the downstream station Annapurnaghat and Badarpurghat. Results obtained using the optimization models are given in the tables and figures presented below

TABLE 6.14 Percentage reduction in peak flow rates in upstream ungauged catchments necessary to create safe flow at Annapurnaghat

Upstream Stations	% diff. in Peak flow		Remarks
Jiri	53.20	Decrease	Safe flow at downstream Annapurna Ghat & Peak flow reduction by 18.80%
Chiri	50.93	Decrease	
Madhura	50.55	Decrease	
Fulertal	Unregulated		
Dholai			
Maniarkhal			

TABLE 6.15 Percentage reduction in peak flow rates for upstream ungauged catchments required to create safe flow at BadarpurGhat

Stations	% diff. in Peak flow		Remarks
Jiri	63.36	Decrease	Safe flow at downstream BadarpurGhat & Peak flow reduction by 17.96%
Chiri	88.65	Decrease	
Madhura	88.05	Decrease	
Jatinga	86.18	Decrease	
Ghagra	84.60	Decrease	
Fulertal	Unregulated		
Dholai			
Maniarkhal			
Matijuri			

TABLE 6.16 Peak flow rates for the Regulated and unregulated catchments upstream of Annapurnaghat (upto Lakshipur) that creates safe flow at Annapurnaghat

Stations	Peak Flow Rates			Average Peak Flow Rate	Remarks
	Event1	Event2	Event3		
Jiri	1512.02	1380.42	1411.52	1434.66	Safe Flow at downstream Annapurna Ghat; No Regulation of flows at Fulertal, Dholai & Maniarkhal
Chiri	1064.64	974.50	1328.90	1122.68	
Madhura	926.37	830.21	1493.67	1083.41	
Fulertal	5296.44	5662.63	4839.62	5266.23	
Dholai	267.64	473.18	471.39	404.07	
Maniarkhal	584.56	917.18	518.14	673.29	

TABLE 6.17 Peak flow rates for the Regulated and unregulated catchments upstream of Badarpurghat (upto Lakshipur) that creates safe flow at Badarpurghat.

Stations	Peak FlowRate			Average Peak Flow Rate	Remarks
	Event1	Event2	Event3		
Jiri	817.29	893.62	1650.06	1120.32	Safe Flow at downstream BadarpurGhat with No Regulation of at Fulertal, Dholai, Maiarkhal & Matijuri
Chiri	251.69	232.77	291.16	258.54	
Madhura	237.44	220.98	300.97	253.13	
Jatinga	225.94	207.29	287.12	240.11	
Ghagra	209.93	206.59	270.51	229.01	
Fulertal	5296.44	5662.63	4839.62	5266.23	
Dholai	267.64	473.18	471.39	404.07	
Maniarkhal	584.56	917.18	518.14	673.29	
Matijuri	1826.13	1515.51	1846.37	1729.34	

The results obtained by using the optimization model shows that for the upper network to have safe flow at d/s Annapurna Ghat the flow rates from the ungauged catchments Jiri, Chiri, Madhura should be below 1434.66, 1122.68, 1083.41 cumecs respectively and the peak flow rates at the unregulated stations Fulertal, Dholai, Maniarkhal are to be less than. 5266, 404 and 673 cumecs respectively. Also, it is seen that safe flow at Badarpurghat occurs when the peak flow rates from the ungauged catchments Jiri, Chiri, Madhura, Jatinga & Ghagra are below 1120.32, 258.54, 253.13, 240.11 & 229.01 cumecs respectively with peak flow rate at Fulertal, Dholai, Maniarkhal, Matijuri less than or equal to 5296, 267, 584, 1826 cumecs respectively. It may be obtained from the results given figures 6.10 and 6.11 that the selected set of peak flow rates for the upstream gauged and ungauged catchments produces safe flow rates at Annapuraghat and Badarpurghat which are below and close to the respective danger level flow at the corresponding sections.

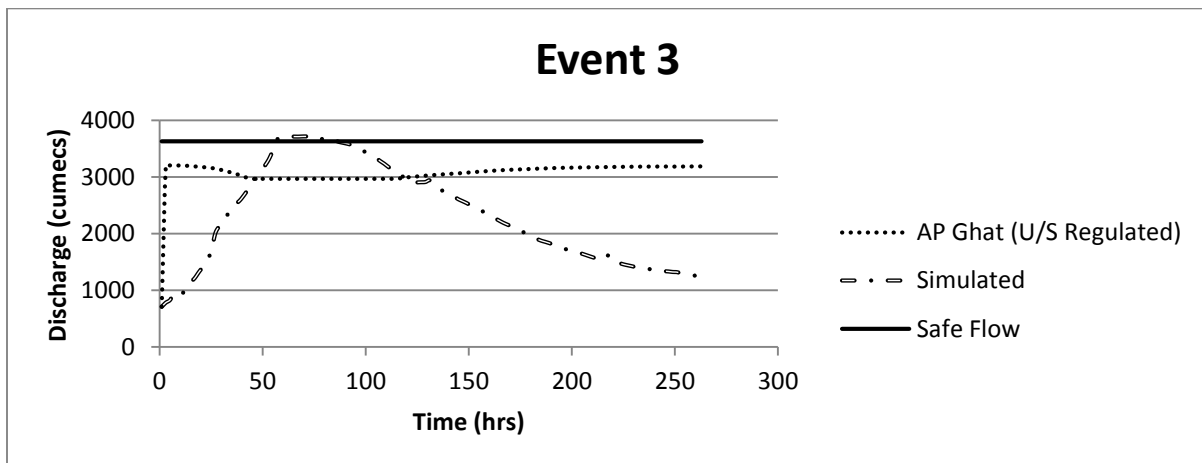
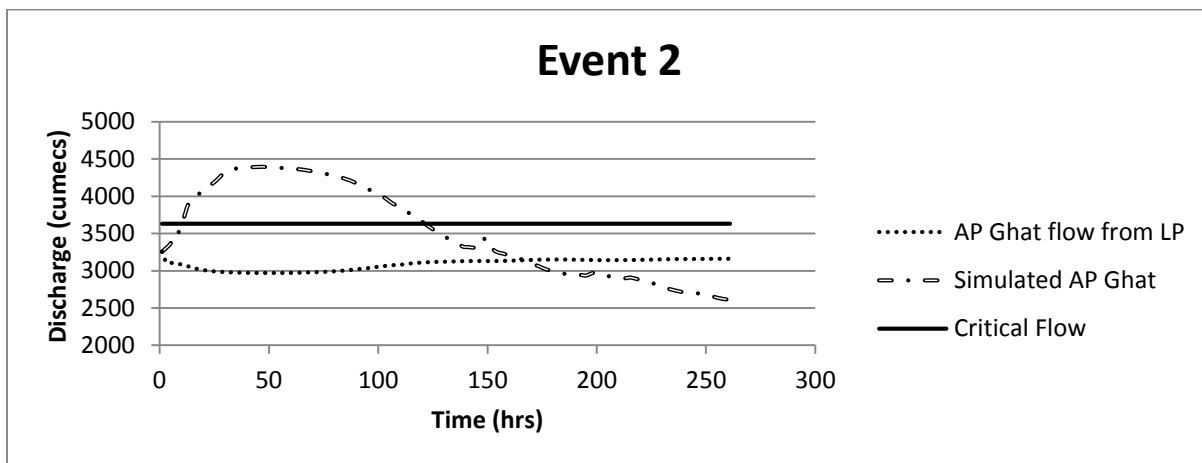
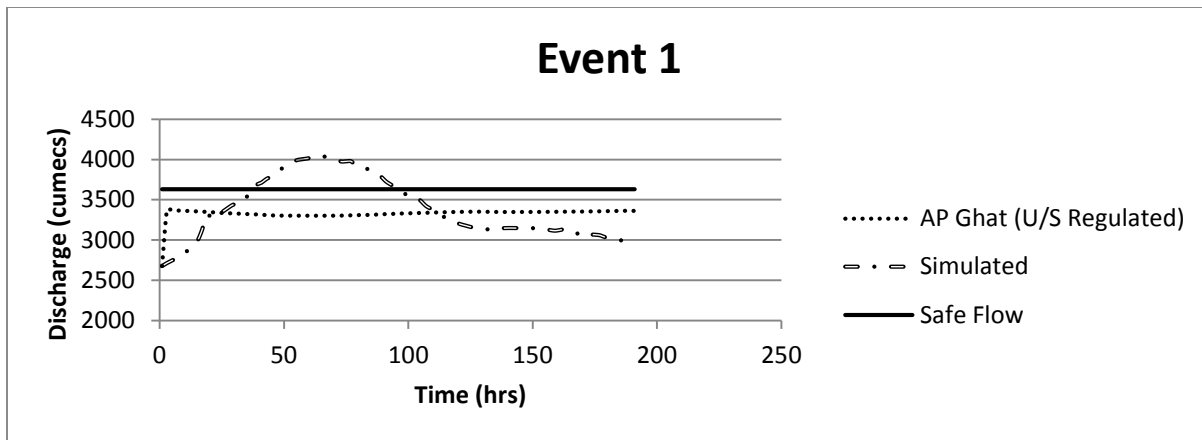

FIGURE 6.10 Flow at Annapurnaghat: observed flow, safe flow and flow by regulating upstream ungauged catchments flows from Jiri, Chiri and Madhura

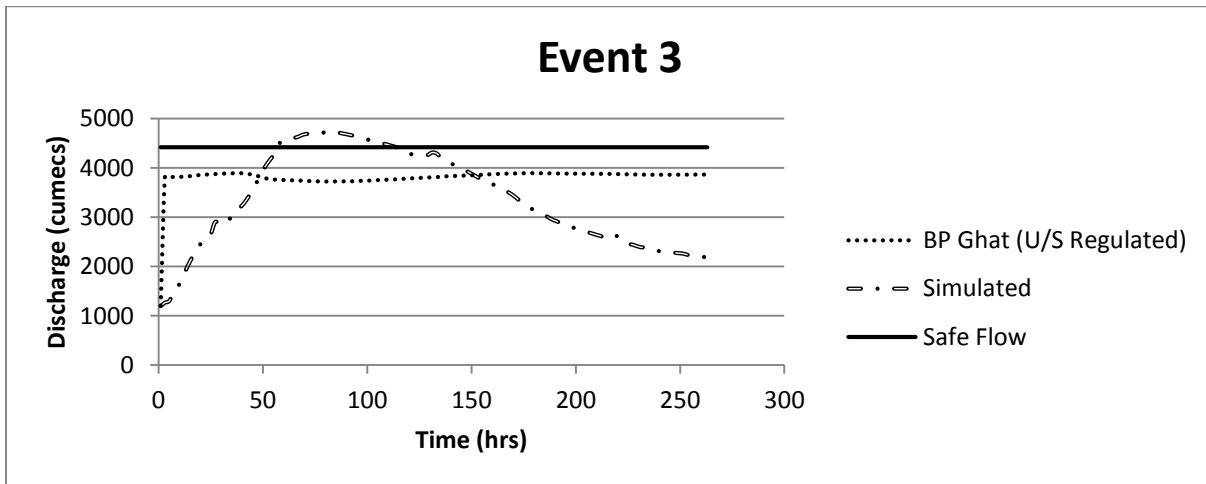
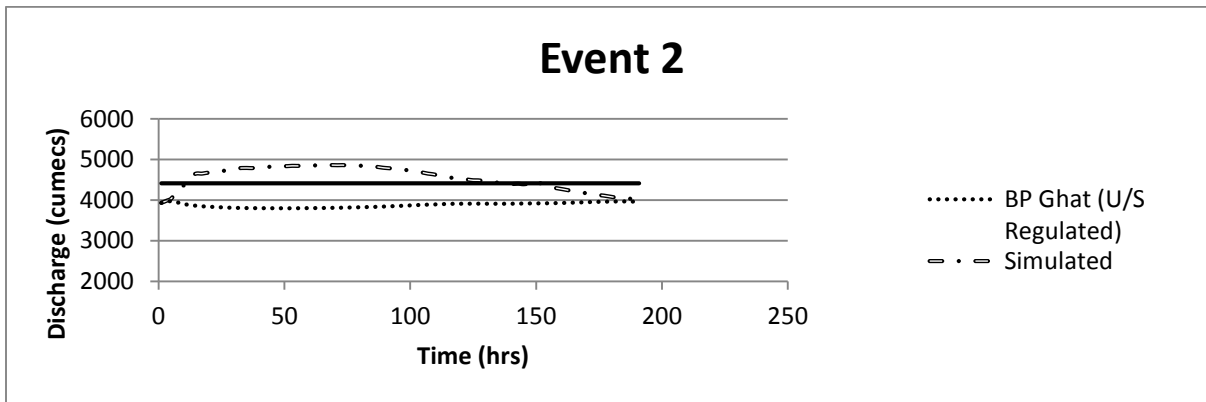
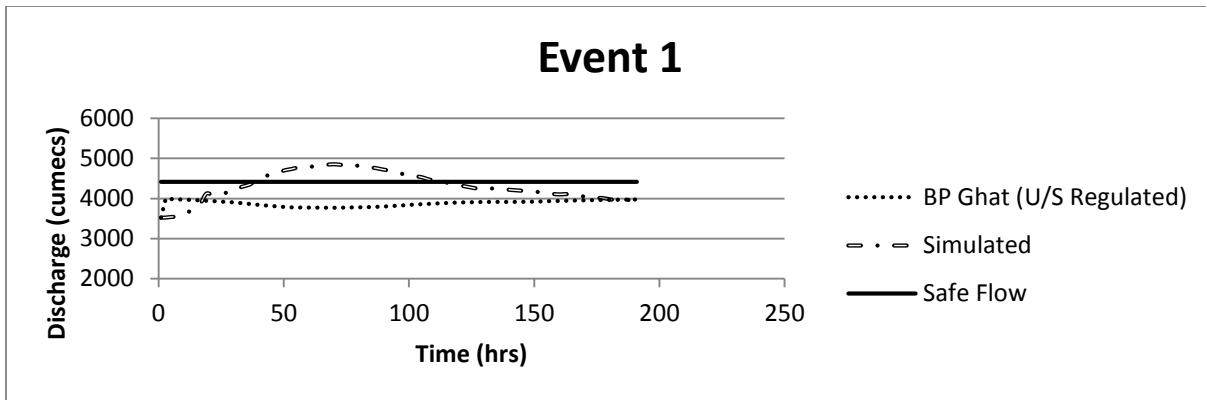

FIGURE 6.11 Flow at Badarpurghat: observed flow, safe flow and flow by regulating upstream ungauged catchments flows from Jiri, Chiri , Madhura, Jatinga & Ghagra

Case – 2: Flow Regulations in all upstream catchments/stations excepting main channel flow considering effects of climate change

The effects of regulating flows from all major upstream catchments including gauged and ungauged catchments on the flood scenarios at the downstream station Annapurnaghat and Badarpurghat are evaluated keeping flows from the main channel at Lakhipur unregulated. This is mainly because restricting the main channel flow at Fulertal may not be feasible on many counts. The flow rates for all catchments upstream of Annapurnaghat and Badarpurghat are maximized with the constraint that the **downstream flow doesn't exceed the safe flow rates and peak** flow rates for these catchments are obtained from the model solution derived using the selected flood events. Peak flow rates obtained for the catchments for flood event-1,2 and three are averaged to find the maximum possible peak flow rates for these catchments that create safe flow at the downstream stations. The model is also run to estimate the maximum allowable peak flow rates for the catchments if there is a rise in the river discharges due to change in the climate. The climate change module study conducted by IIT Guwahati indicated 10 to 20% increase in the rainfall /flow rates due to change in the climate; the effects of increased flow rates are also studied and the results obtained are summarized in Tables-6.18 and 6.19

TABLE 6.18 Peak flow rates for the gauged and ungauged regulated catchments upstream of Annapurnaghat (upto Lakshipur) with no regulation of flow in the main channel necessary to create safe flow at Annapurnaghat including and not including effects of climate change.

Stations	Peak Flow Rate									Average Peak Flow Rate			Remarks
	Event1			Event2			Event3			0% increase	10% increase	20% increase	
	0% increase	10% increase	20% increase	0% increase	10% increase	20% increase	0% increase	10% increase	20% increase				
Jiri	2765.00	2765.00	2765.00	2920.09	2920.09	2538.88	2778.56	2778.56	2778.56	2821.22	2821.22	2694.15	Safe Flow at downstream Annapurna Ghat
Chiri	517.63	545.55	565.31	461.20	530.98	998.12	552.14	596.77	587.19	510.32	557.77	716.87	
Madhura	454.34	477.63	493.67	391.10	450.55	814.43	617.81	670.00	658.85	487.75	532.73	655.65	
Dholai	117.98	118.69	118.73	160.60	172.35	228.00	247.70	246.43	246.03	175.43	179.16	197.59	
Maniarkhal	192.93	197.71	200.17	248.34	280.08	443.88	197.92	200.89	199.79	213.06	226.23	281.28	
Fulertal	5296.4	5826.1	6355.7	5662.6	6228.9	6795.2	4839.6	5323.6	5807.5	5266.2	5792.9	6319.5	

TABLE 6.19 Peak flow rates for the gauged and ungauged regulated catchments upstream of Badarpurghat (upto Lakshipur) with no regulation of flow in the main channel necessary to create safe flow at Badarpurghat including and not including effects of climate change

Stations	Peak Flow Rate									Average Peak Flow Rate			Remarks	
	Event1			Event2			Event3			0% increase	10% increase	20% increase		
	0% increase	10% increase	20% increase	0% increase	10% increase	20% increase	0% increase	10% increase	20% increase					
Jiri	1044.41	1011.96	976.74	764.15	766.21	764.85	944.69	952.79	960.49	917.75	910.32	900.70	Safe Flow at downstream Badarpur Ghat	
Chiri	252.65	250.02	247.44	273.10	270.26	267.45	309.68	307.78	305.91	278.48	276.02	273.60		
Madhura	248.18	245.53	242.92	266.98	264.17	261.37	314.04	312.17	310.33	276.40	273.96	271.54		
Dholai	133.37	133.36	133.35	202.77	200.92	199.05	217.05	216.84	216.64	184.40	183.71	183.01		
Maniarkhal	197.55	195.52	193.47	243.06	240.52	237.98	220.60	219.41	218.22	220.40	218.48	216.56		No flow regulation in the main channel
Jatinga	243.94	241.31	238.70	257.96	255.23	252.50	307.73	305.82	303.94	269.88	267.45	265.04		
Ghagra	236.70	234.11	231.53	257.44	254.71	251.99	298.24	296.34	294.44	264.13	261.72	259.32		
Matijuri	305.90	301.57	297.25	263.48	261.46	259.43	659.81	659.07	658.34	409.73	407.37	405.01		
Fulertal	5296.44	5826.08	6355.73	5662.63	6228.89	6795.15	4839.62	5323.58	5807.54	5266.23	5792.85	6319.47		

Tables-6.18 and 6.19 show the maximum peak flow rates for the upstream catchments that produce safe flow at the potential downstream damage stations.

The results show that the allowable peak flow rate for the catchments decreases marginally due to increase in the river discharges for changes in the climate in next 50-60 years. Though the peak outflow rate for the upstream catchments necessary to maintain safe flow rate at the D/s stations are only marginally decreased but, the requirement of additional storage arrangement in the catchments to account for the changes in the climate would be comparatively large as the said storage arrangements must hold the additional volume coming due to increase in the inflow rates which is predicted to be around 10-20% in next 50 to 60 years. Results given in the tables 6.16 and 6.17 indicates the allowable maximum peak flow rates for the catchments when only some of the upstream catchments are regulated while, the results given in the table 6.18 and 6.19 are the maximum peak flow rates if all upstream catchments except the main channel are regulated. It may be seen that in both the cases considered in the study safe flow at the potential D/S locations is resulted and in the second case (table 6.18 and 6.19) D/S flow is much lesser than the safe limit due to higher reduction in the u/s peak flow rates. Considering the results given in Table-6.19 **under the heading "0% increase" and the figures 6.12-6.17** it can be seen that the set of peak flow rate selected for the upstream catchments produces safe flow at both Annapurnaghat and Badarpurghat well below the corresponding danger limit and change marginally if upstream flows increases by 10% to 20% due to climate change. It may be mentioned here that though by regulating all upstream catchments as given by Table 6.19 increased safety at the downstream damage sections can be assured however considering the requirements of storage facilities in the upstream catchments required this option may not much preferable over the earlier solution obtained in case-I.

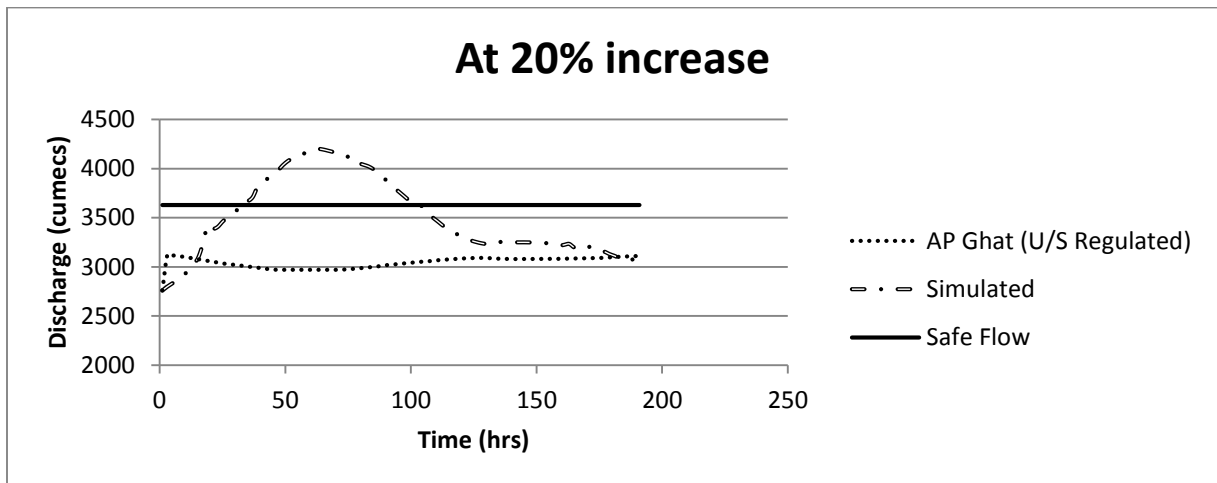
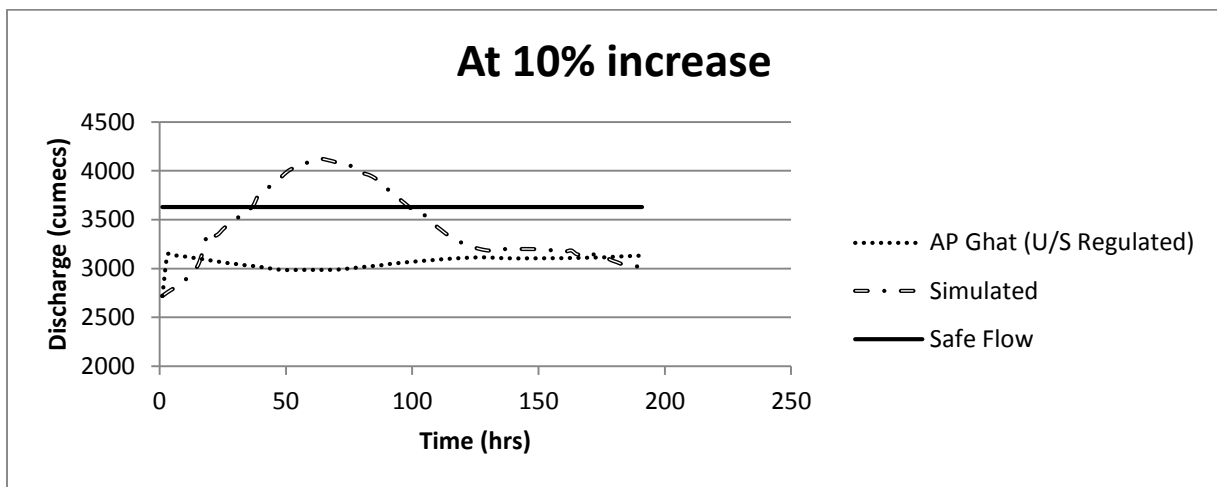
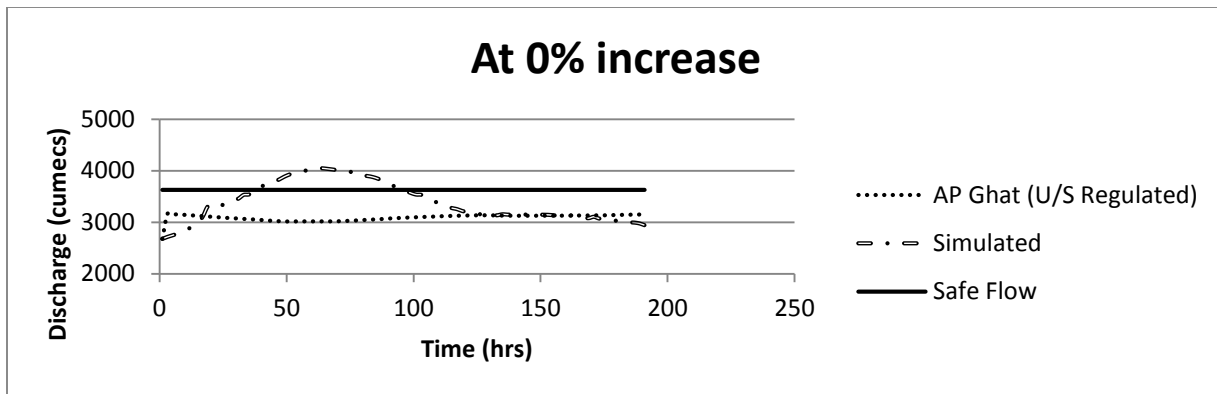

FIGURE 6.12 Flow at Annapurna Ghat (Event-1) including and not including effects of climate change: U/S flow regulation-all catchment

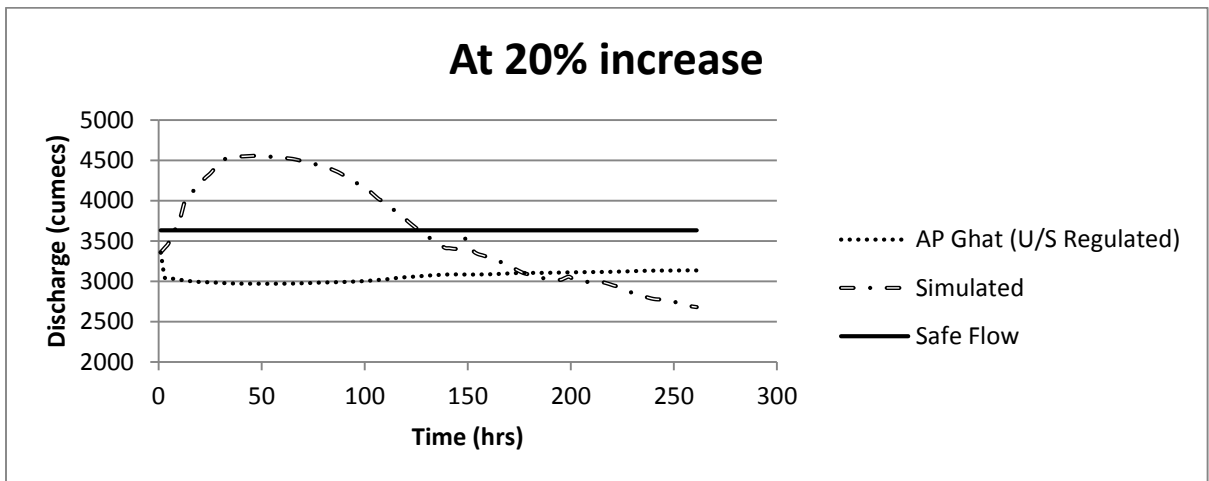
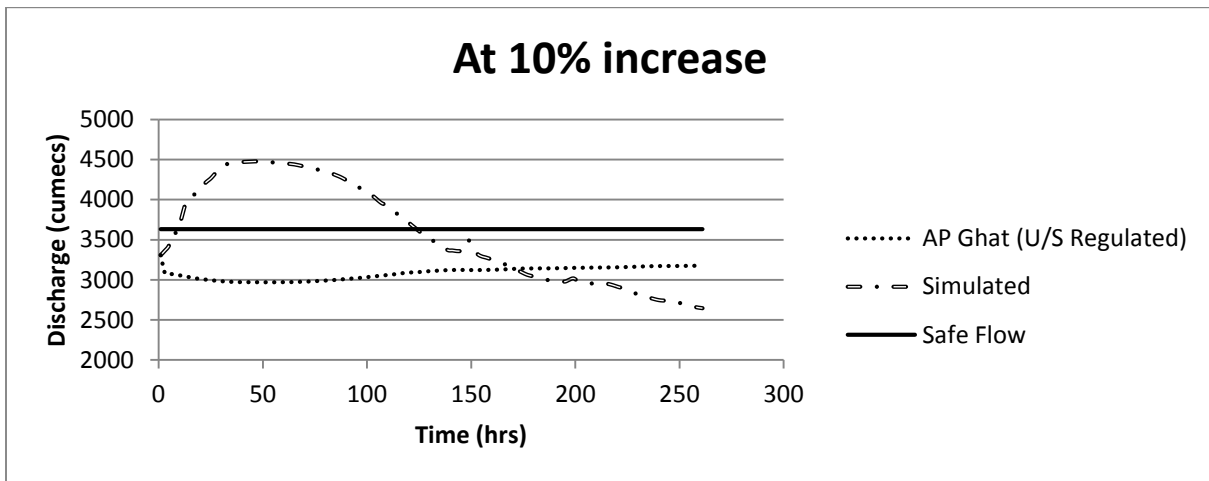
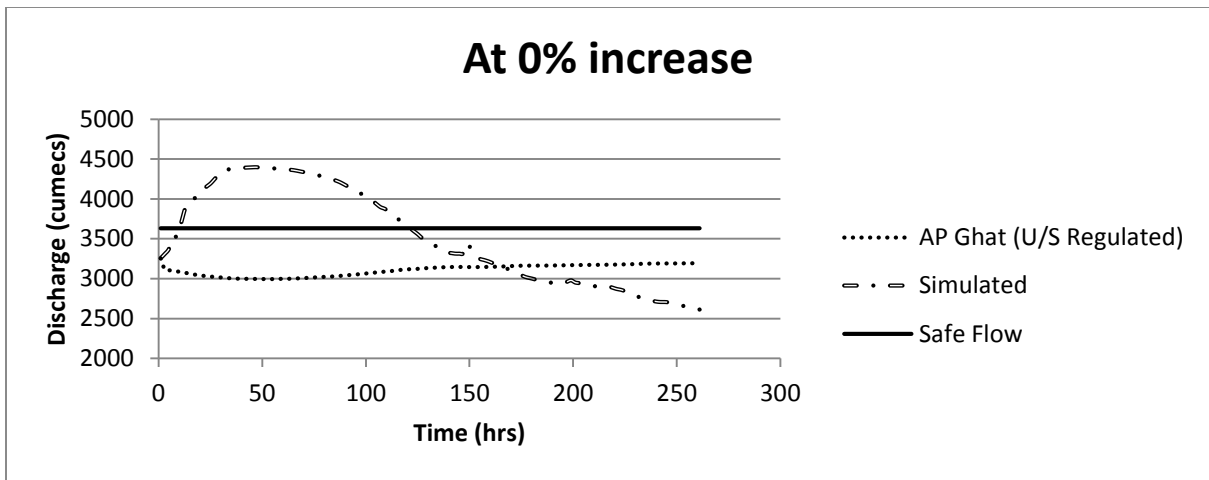

FIGURE 6.13 Flow at Annapurna Ghat (Event-2) including and not including effects of climate change: U/S flow regulation-all catchment

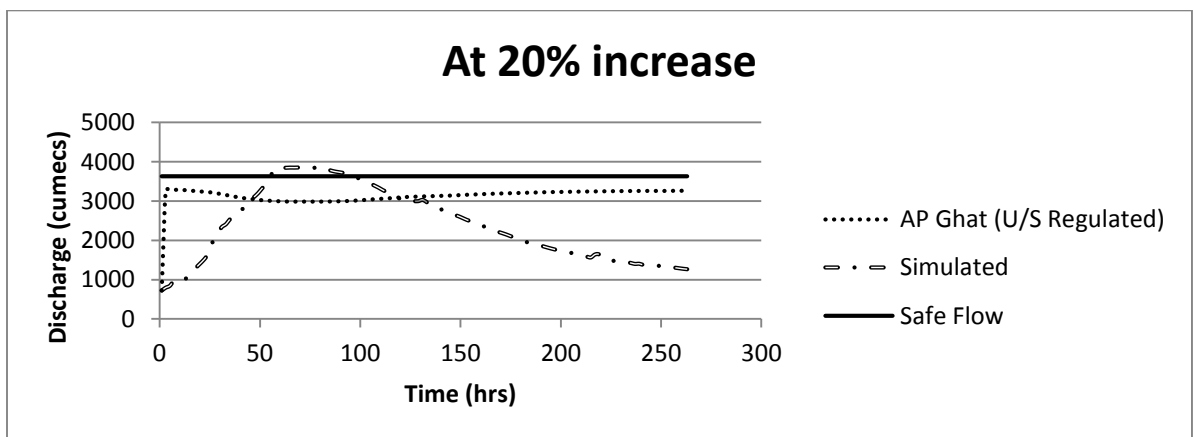
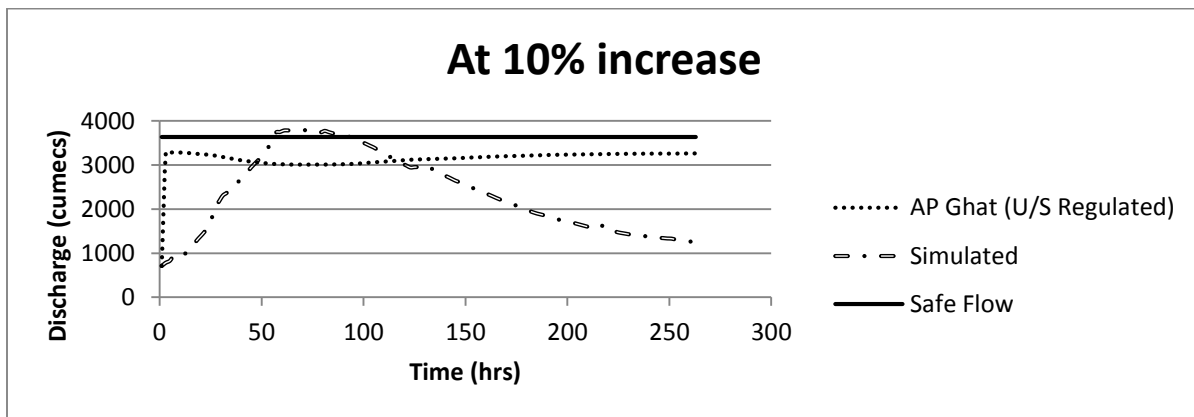
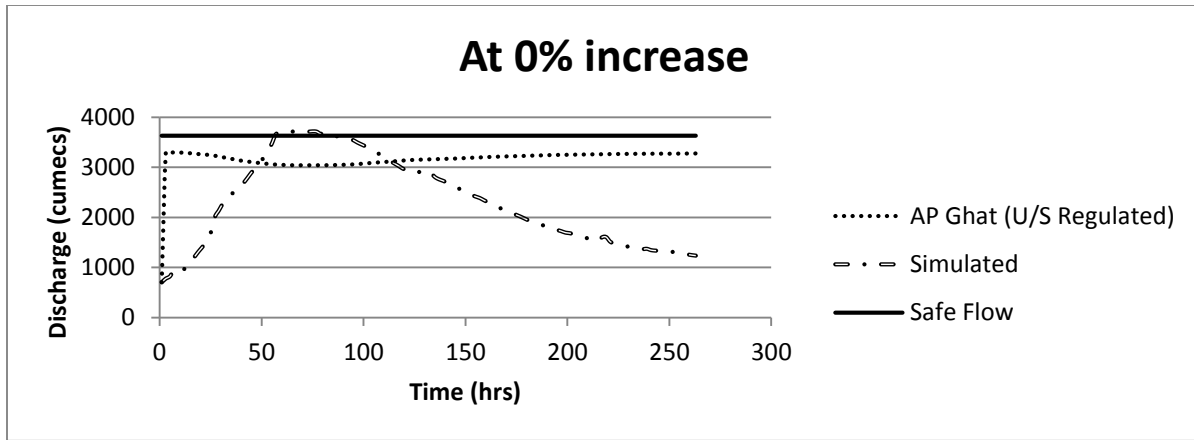

FIGURE 6.14 Flow at Annapurna Ghat (Event-3) including and not including effects of climate change: U/S flow regulation-all catchment

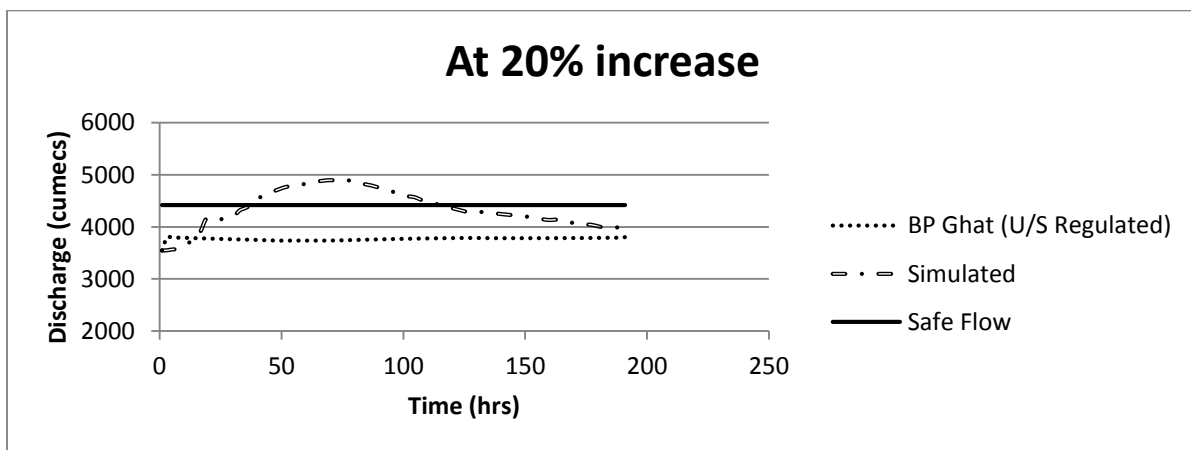
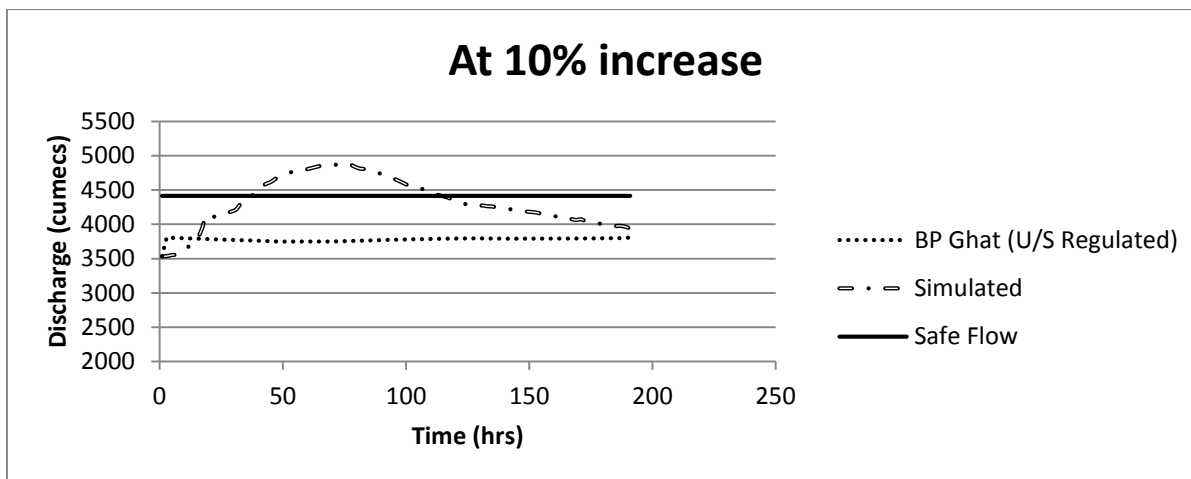
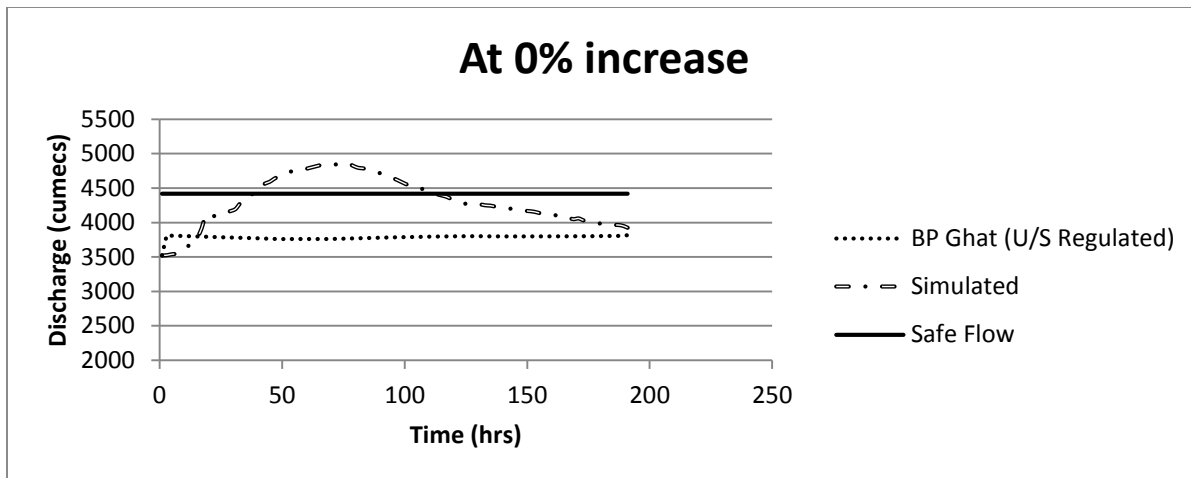

FIGURE 6.15 Flow at BadarpurGhat (Event-1) including and not including effects of climate change: U/S flow regulation-all catchment

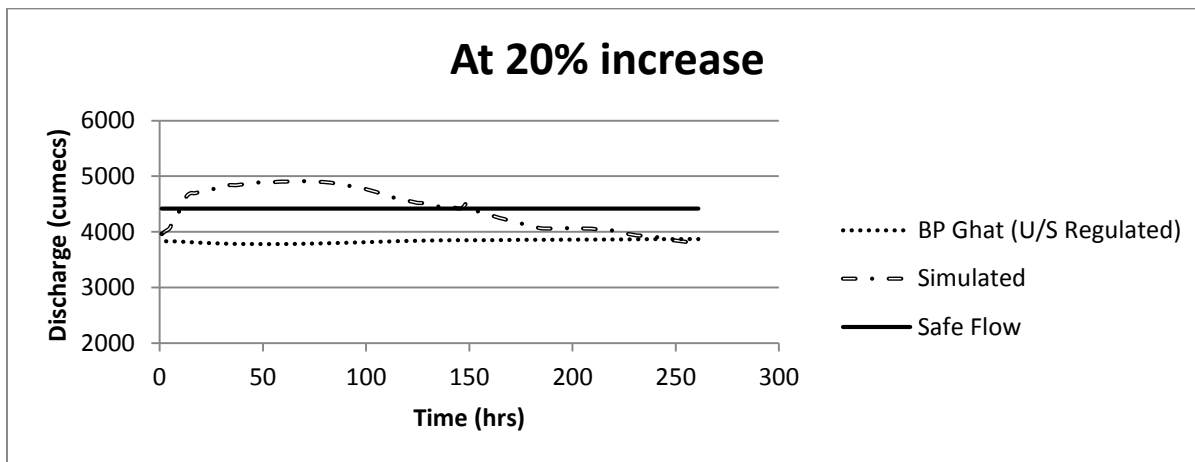
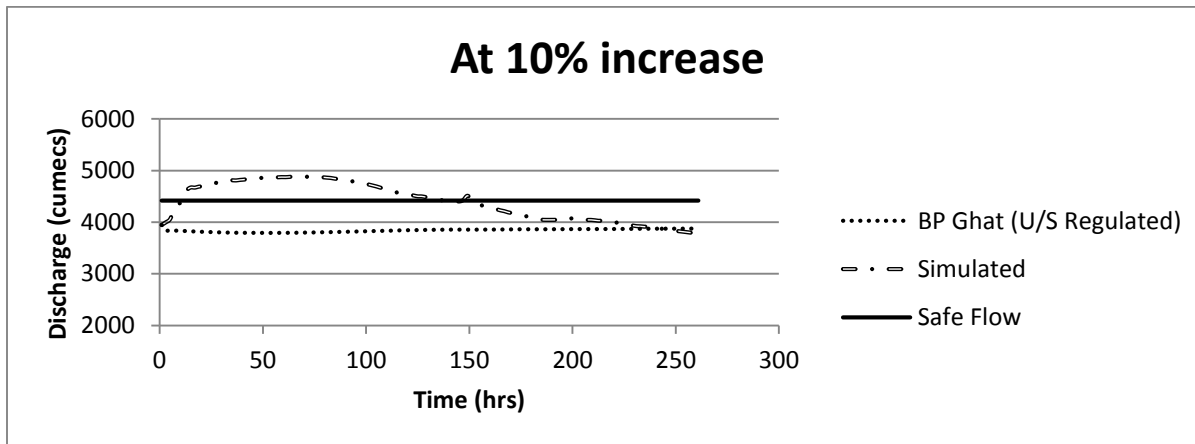
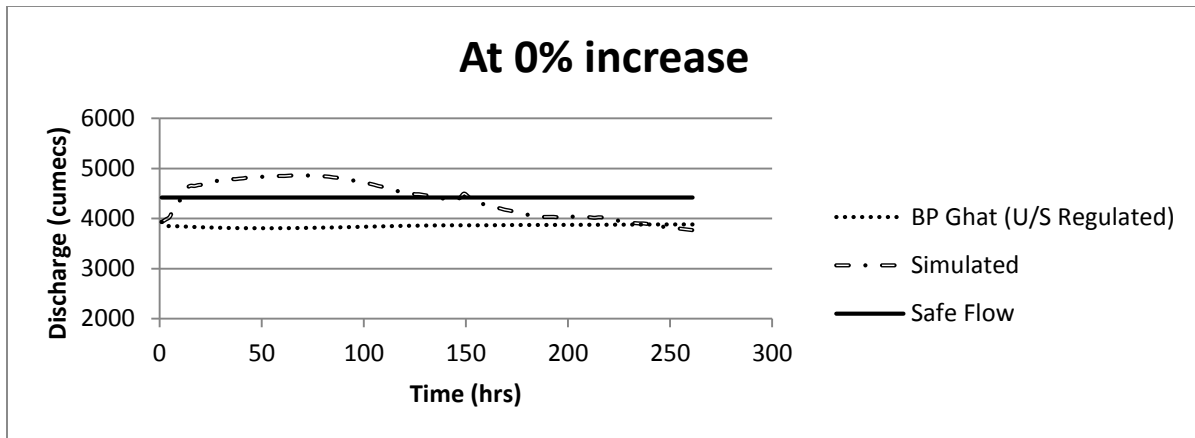

FIGURE 6.16 Flow at BadarpurGhat (Event-2) including and not including effects of climate change: U/S flow regulation-all catchment

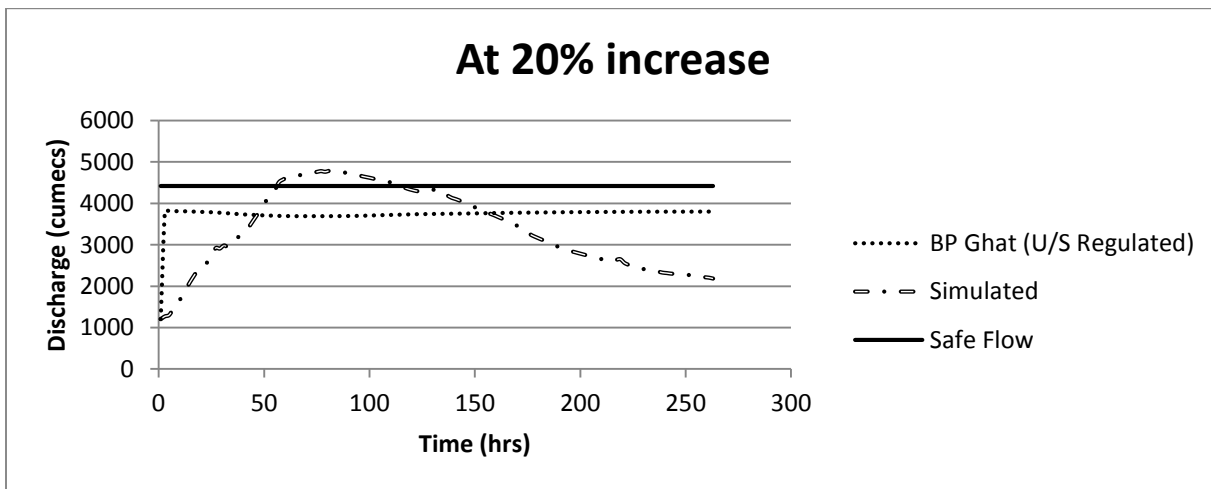
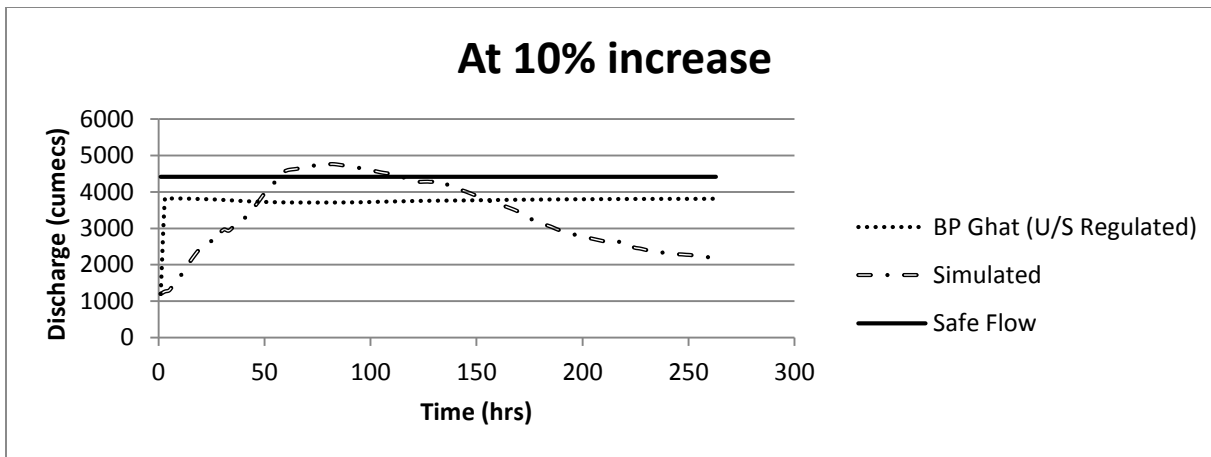
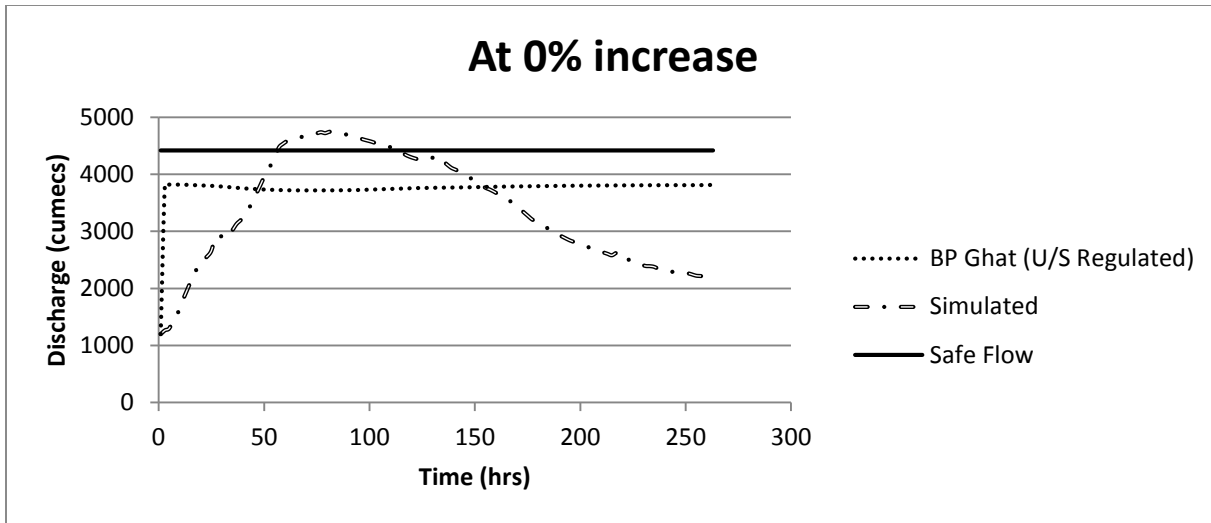

FIGURE 6.17 Flow at BadarpurGhat (Event-3) including and not including effects of climate change: U/S flow regulation-all catchment

7.0 River System Sediment Flow Analysis:

In the present study to simulate sediment flow along the main river course that receives sediment flows from different catchment integrated water-sediment flow model for the river system is calibrated. For the upper and lower river systems the integrated water-sediment model given by equation 7.1 and 7.2 are calibrated using the water discharge and sediment discharge /concentration data collected for the gauging sites from CWC Shillong.

$$C_{s,(t+\Delta t)}^d = \alpha_d \left[c_1 \left(\sum_{p=1}^n \sigma^{u,p} \left(\frac{C_{s,t}^{u,p}}{\alpha_{u,p}} \right)^{\frac{1}{\beta_{u,p}}} \right) + (1 - c_1 - c_3) \left(\sum_{p=1}^n \sigma^{u,p} \left(\frac{C_{s,(t+\Delta t)}^{u,p}}{\alpha_{u,p}} \right)^{\frac{1}{\beta_{u,p}}} \right) + c_3 \left(\frac{C_{s,t}^d}{\alpha_d} \right)^{\frac{1}{\beta_d}} \right]^{\beta_d} \quad (7.1)$$

$$Q_{s,(t+\Delta t)}^d = \alpha_d \left[c_1 \left(\sum_{p=1}^n \sigma^{u,p} \left(\frac{Q_{s,t}^{u,p}}{\alpha_{u,p}} \right)^{\frac{1}{(\beta_{u,p}+1)}} \right) + (1 - c_1 - c_3) \left(\sum_{p=1}^n \sigma^{u,p} \left(\frac{Q_{s,(t+\Delta t)}^{u,p}}{\alpha_{u,p}} \right)^{\frac{1}{(\beta_{u,p}+1)}} \right) + c_3 \left(\frac{Q_{s,t}^d}{\alpha_d} \right)^{\frac{1}{(\beta_d+1)}} \right]^{\beta_d+1} \quad (7.2)$$

Where

$C_{s,t}^{u,p}, Q_{s,t}^{u,p}$ = Equivalent sediment concentration & sediment discharge at p due to sediment discharges at n different locations.

$\sigma^{u,p}$ = shift factor associated with the transfer of flow from u to p

$C_{s,t}^u$ = sediment concentration at point p

$Q_{s,t}^{u,p}$ = Sediment discharge at point p

α_u, β_u = Rating curve parameters & α_u has the dimension of sediment density & β_u is an exponent.

The model parameters in equation (7.1) and (7.2) are estimated using genetic algorithm. Multi-objectives optimization tool NSGA-II is used to estimate the model parameters in the water-sediment integrated model by minimizing sum of the squared deviations between downstream observed and computed water discharge, sediment discharge and sediment concentrations in the river system.

Upper network with Downstream sediment outflow station at Annapurnaghat

In the upper network, Fulertal & Dholai are the upstream section with Annapurna Ghat as the downstream section. Based on the size of network, 10 model parameters are required to be estimated in this network. Applying simulation models, these model parameters are estimated using first set of inflow-outflow data and three objective functions $f(1)$, $f(2)$ & $f(3)$ minimizing the sum of squared error between observed and predicted sediment concentration, sediment and water discharge. The model parameters estimated for this network are shown in TABLE: 6.13. Using these estimated model parameters the downstream sediment discharge and sediment concentration values are predicted. The models performance are tested using standard statistical criterion "root mean squared error" & "coefficient of correlation"

TABLE 7.1 Model Parameters for Upper Network

β =B.P Ghat	0.3899
β 2=Matihuri	0.3897
α 2=Matihuri	0.9487
α 2=Matihuri	0.8903
β 1=A.P Ghat	0.4264
α 1=A.P Ghat	0.5282
α 1=A.P Ghat	0.9893
α d/s-B.P dhat	0.6118
C_3	0.74969
C_2	0.11205
C_1	0.13827
X	0.01477
K	3.54736

As the models are applied in the multiple river reaches, equivalent inflow is used in the models to obtain the model parameters. Sediment concentration, sediment discharge and water discharge at downstream section are computed based on the equivalent inflow only. Effect of each of the tributaries on the downstream section is assessed by restricting the sediment flow of the tributaries. Restriction of tributary sediment flow may is done one by one at a time and two at a time. Observed and simulated sediment concentration/sediment discharge at the

downstream locations Annapurnaghat and Badarpurghat obtained by applying the models given in equation (7.1) and (7.2) are presented in the following figures

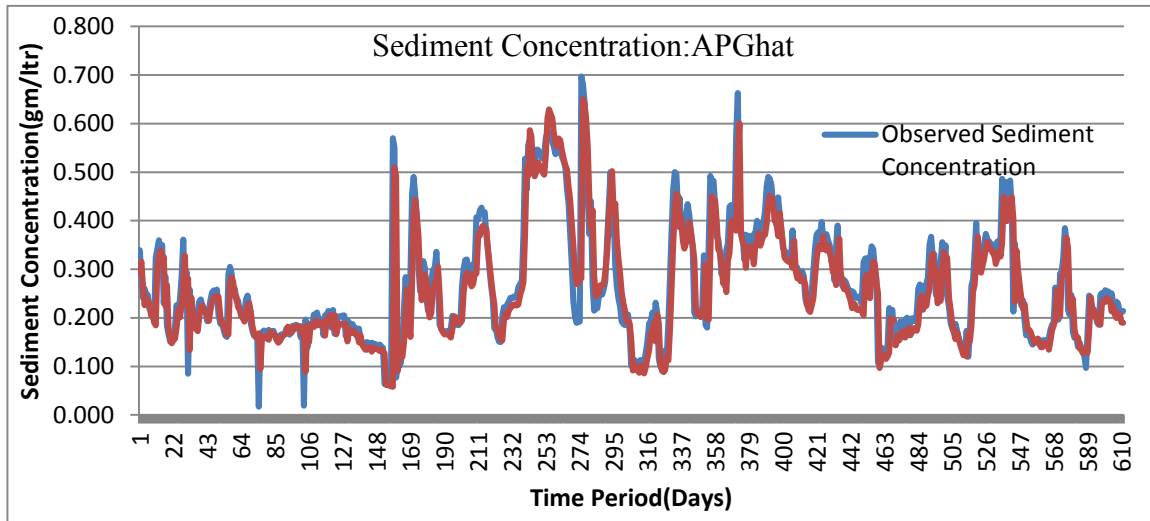

FIGURE 7.1 Observed Sediment Concentration & simulated sediment concentration in upper network

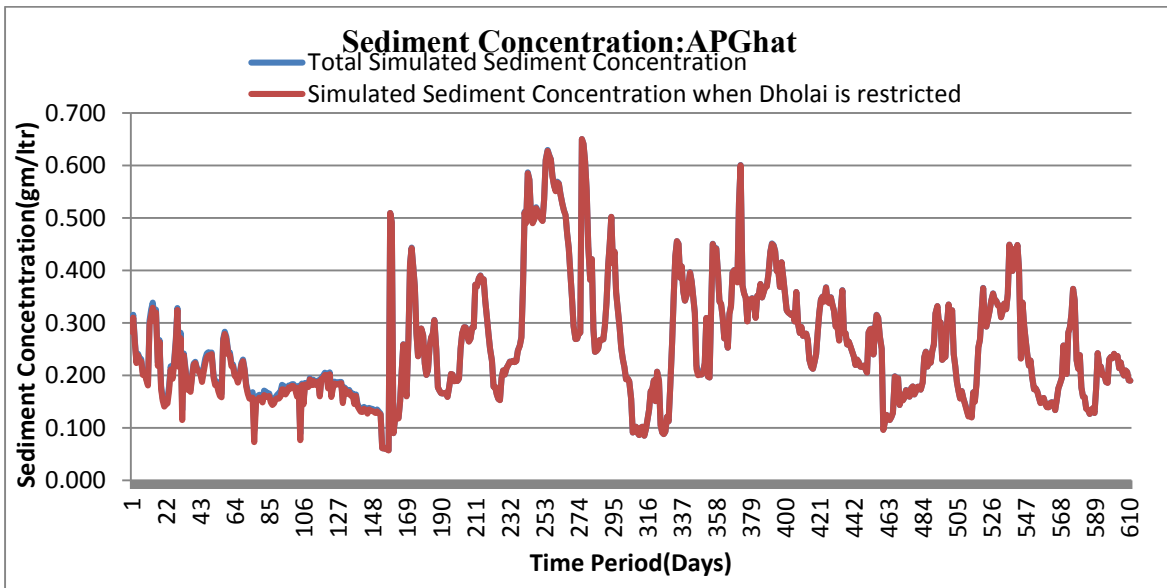

FIGURE 7.2 Sediment Concentration at AP Ghat for no sediment flow from Dholai catchments

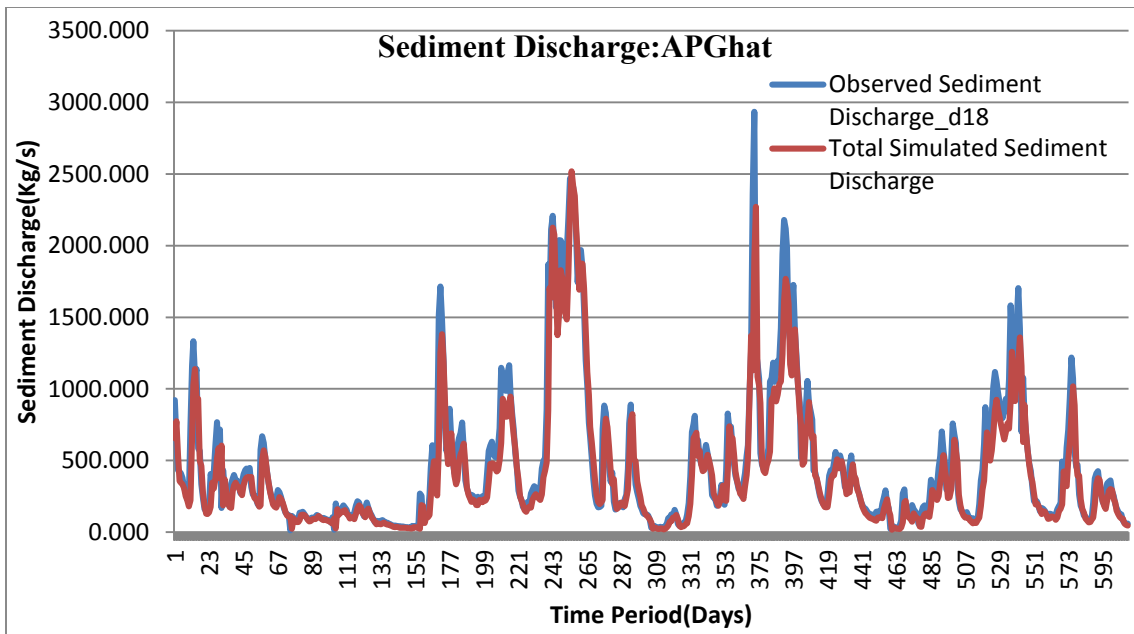

FIGURE 7.3 Observed Sediment and simulated sediment discharge at AP Ghat in upper network

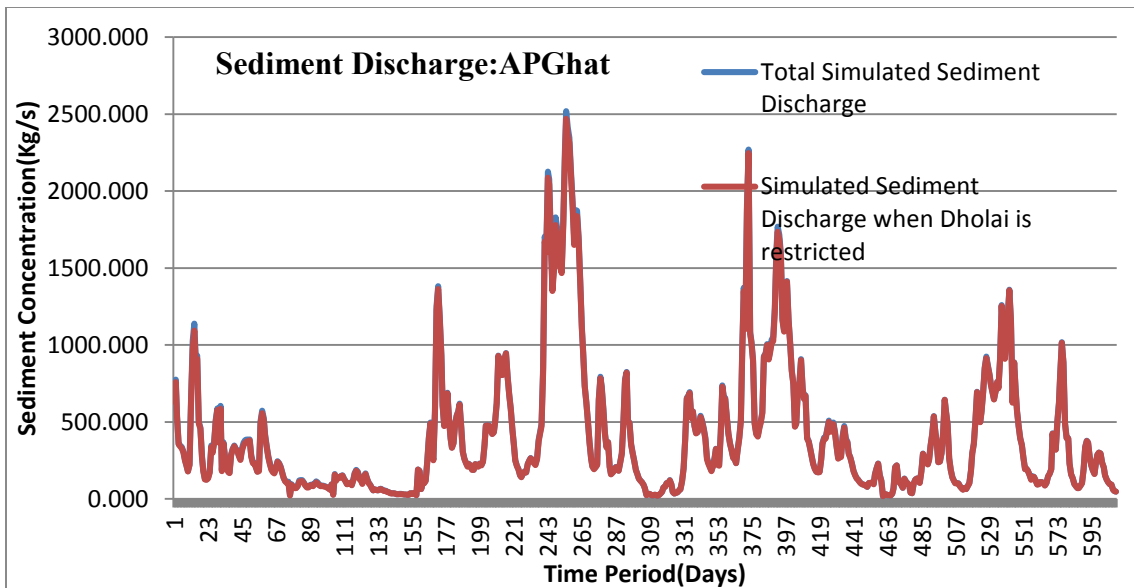

FIGURE 7.4 Sediment Discharge at Annapurnaghat for no sediment flow from Dholai

Complete River System with outflow at Badarpurghat:

In the larger river network, Fulertal, Dholai & Matijhuri are the upstream sections with BadarpurGhat as the downstream section. Based on the size of the network, 13 model parameters are required to be estimated to define the sediment flow simulation model for the network. The model parameters are estimated using a set of inflow-outflow data & tested on other set of inflow-outflow data series. The model parameters estimated for this network are shown in table-7.2:

TABLE 7.2 Model parameters for complete River system

	$\beta_{d=}$ B.P Ghat	1.0001
	$\beta_3=$ Matijhuri	1.9913
	$A_3=$ Matijhuri	3.3252
	$\beta_3=$ Matijhuri	0.4912
	$\beta_2=$ Dholai	0.9943
	$\alpha_2=$ Dholai	2.5317
	$\alpha_2=$ Dholai	0.7521
	$\beta_1=$ Fulertal	0.8164
	$\alpha_1=$ Fulertal	2.1693
	$\alpha_1=$ Fulertal	1.7079
	$\alpha_{d/s=}$ B.P dhat	0.1266
	C_3	0.83041
	C_2	-0.02070
	C_1	0.19029
	X	0.1034
	K	6.0186
D/S	B.P Ghat	
U/S	1.Fulertal 2..Dholai 3.Matijhuri	
Network	Lower Network	
Sl. No	1.	

Sediment concentration, sediment discharge & water discharge at the downstream stations are computed by using estimated parameters & compared with respective observed values. To assess the relative impacts of sediment flow from different tributaries sediment flow from the tributaries are restricted and the resulting peak sediment discharge/concentration at the downstream locations is derived from the model results. The sediment discharge and sediment concentration graphs obtained by restricting sediment flows from the catchments are shown in the figures 7.5 to 7.9 given in the next pages.

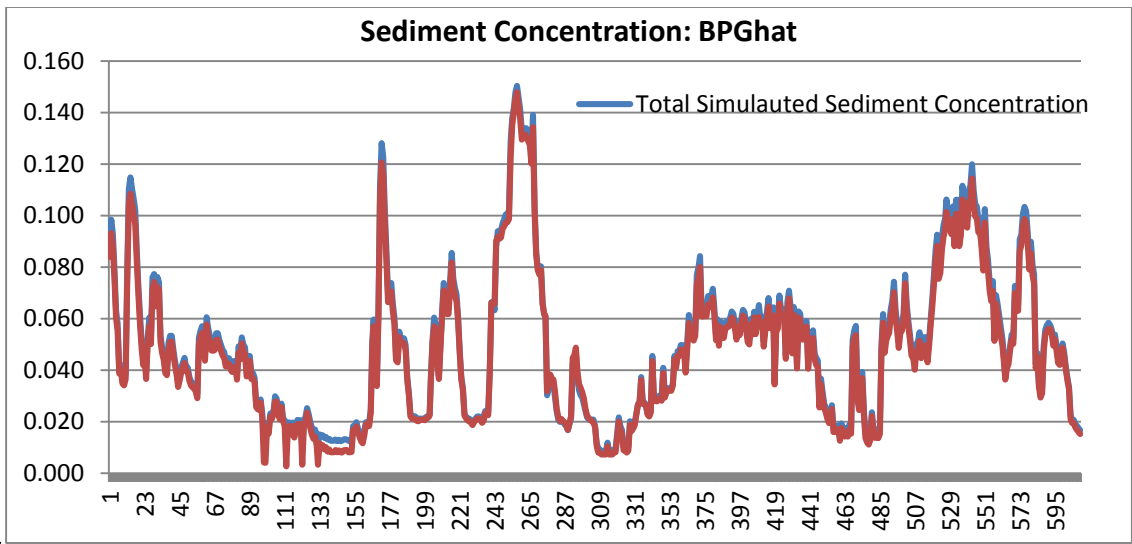

FIGURE 7.5 sediment concentration for no sediment flow from Dholai

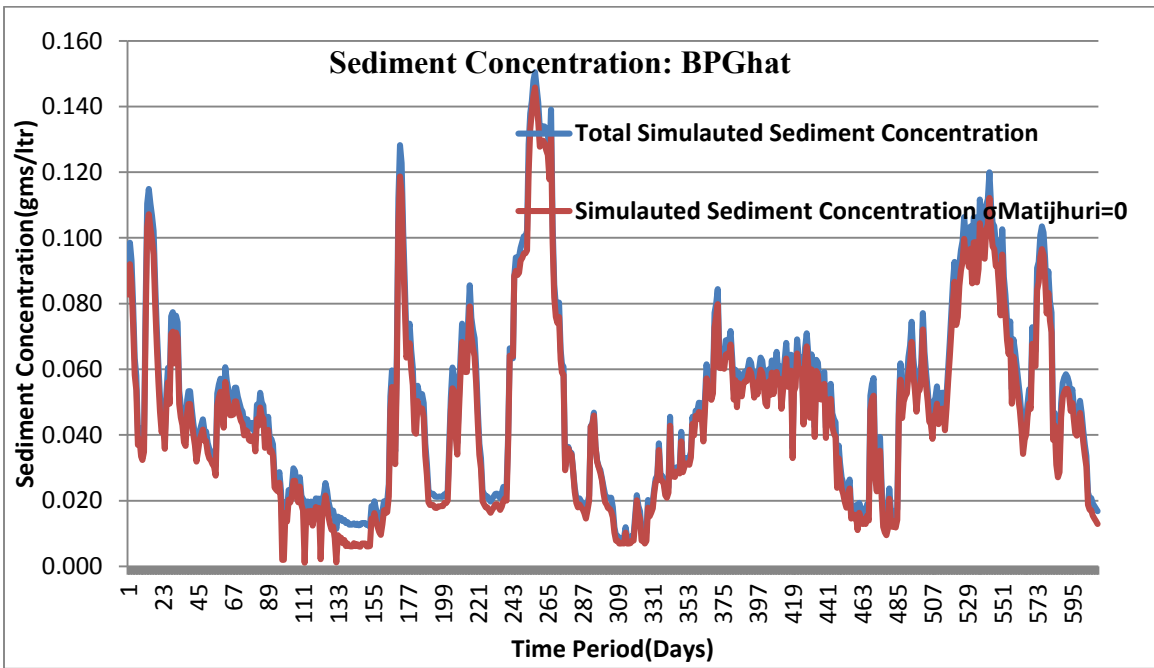

FIGURE 7.6 Sediment concentration for no sediment flow from Madhura,

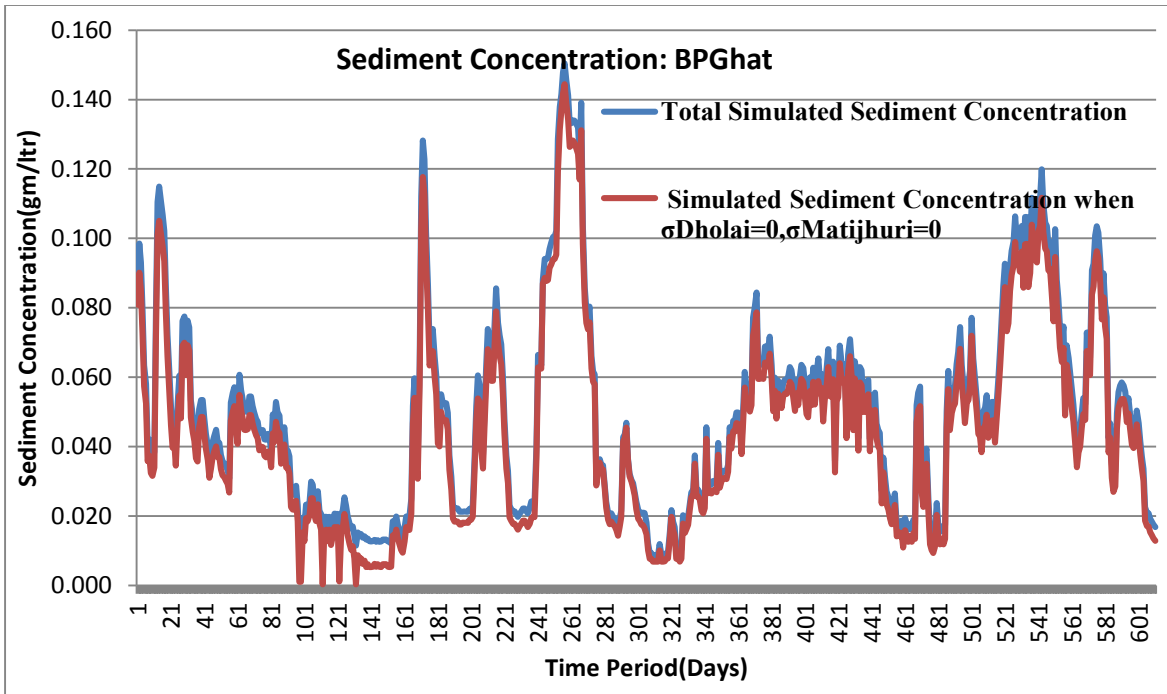

FIGURE 7.7 Observed sediment concentration and concentration at BPghat for no sediment flow from Dholai and Madhura subcatchments

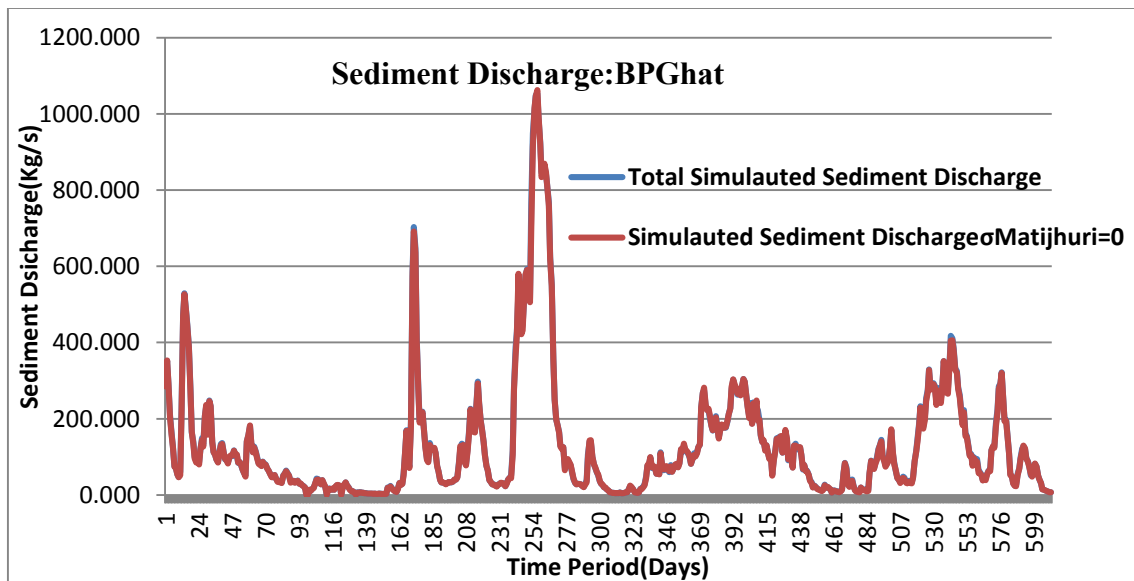

FIGURE 7.8 Sediment discharge for no sediment flow from Matijuri

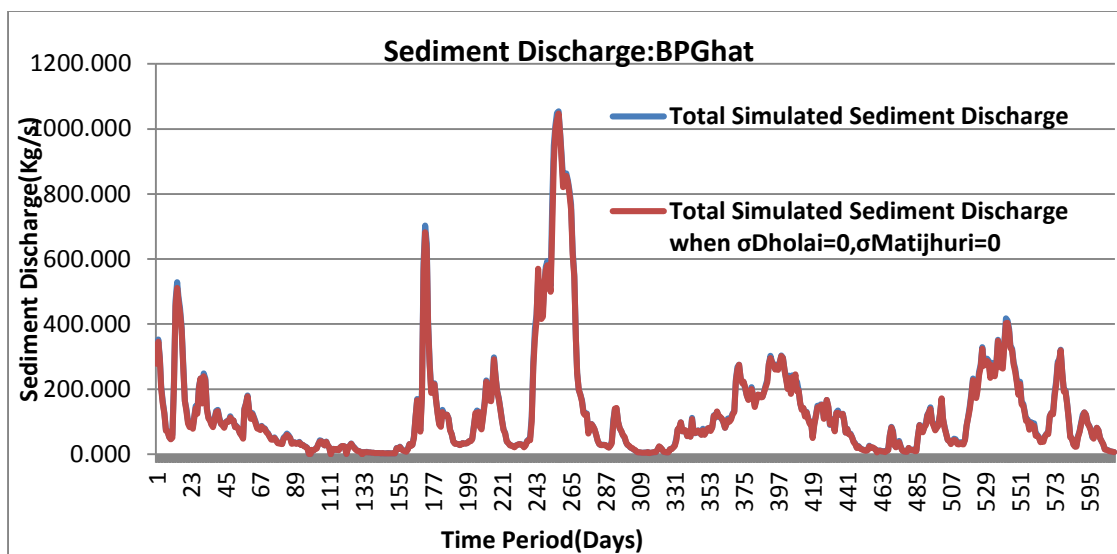

FIGURE 7.9 Sediment discharge for no sediment flow from Matijhuri and Dholai sub-catchments.

TABLE 7.3 Impact of sediment flow from upstream catchments at Badarpurghat

		Sediment Concentration					Sediment Discharge				
	Peak values	Observed Sediment Concentration-B.P GHAT	Dholai restricted	Matijhuri restricted	Improvement due to Dholai restriction	Improvement due to Matijhuri restriction	Observed Sediment discharge-B.P GHAT	Dholai restricted	Matijhuri restricted	Improvement due to Dholai restriction	Improvement due to Matijhuri restriction
Sediment Load (kg)		0.164	0.145	0.143	0.018	0.020	86210.90	78010.86	78066.36	8200.03	8144.535
							1090.60	1038.41	1045.60	52.19	44.9968

TABLE 7.4 Impact sediment flow from upstream catchments at Annapurnaghat

Sediment Concentration				Sediment Discharge		
	Observed Sediment Concentration-A.P Ghat	Restricted	Improvement	Observed Sediment Discharge	Restricted	Improvement
Peak values	0.697	0.281	0.416	718.607	220.2834	498.324
Sediment Load(kg)	-	-	-	286569.7	246840.9	39728.87

As indicated in the above tables the relative contribution of sediment from the Matijuri catchments is more compared to the other catchments considered in the study. It is found that for no sediment flow from the Matijuri catchments the sediment load at Badarpurghat reduces by 10.46 % and the peak sediment concentration decreases by 12.36%. In the case of Dholai sub catchment the improvement in sediment load at Badarpurghat is around 9.23% and reduction in peak sediment concentration rate is 9.25%.

8.0 Flood forecasting in the river system

The downstream flow top width and downstream discharge in a river reach can be forecasted using upstream levels/ discharge rates. In the present study a hybrid Muskingum models is used to forecast downstream discharge rates and flow top width in the river system on the basis of flow depths measured at several upstream locations. The multiple flow routing model given in equation 6.1 is rewritten to describe the downstream flow top width in terms of upstream flow depth at several upstream stations as given in equation 8.1

$$T_{(t+\Delta t)}^{(d)} = \left(\left(c_1 (\sigma^{1,r} Q_t^{1,u} + \sigma^{2,r} Q_t^{2,u} + \dots + \sigma^{n,r} Q_t^{n,u}) + (1 - c_1 - c_3) (\sigma^{1,r} Q_{t+\Delta t}^{1,u} + \sigma^{2,r} Q_{t+\Delta t}^{2,u} + \dots + \sigma^{n,r} Q_{t+\Delta t}^{n,u}) + c_3 (\alpha_d T_t^{\beta_d}) \right) / \alpha_d \right)^{1/\beta_d} \quad (8.1)$$

Here, $T_{(*)}^{(d)}$ denotes downstream flow top width, t , $t+\Delta t$ represent the time-period. c_1 , c_2 , c_3 are the routing coefficients. $Q_t^{1,u}$ = Instantaneous water discharge (m^3/s) at upstream section 1 at time t . $\alpha_{(d)}$, $\beta_{(d)}$ = rating curve parameters reflecting water discharge characteristics for the downstream section and $T_t^{(d)}$ = Instantaneous flow top width at a section at time t at the downstream section. Eqn (8.1) gives the hybrid multiple inflows Muskingum model incorporating discharge and flow top width variables for a river system. The model is highly non-linear involving a number of parameters. The model relates discharges separated by a time interval Δt for various upstream and the downstream stations in a river system, satisfy continuity requirements adhering to the Muskingum principle of flow movement in river reaches. The model allows directly estimating downstream flow top width on the basis of water discharges for different upstream stations.

Model parameters in equation (8.1) could be estimated by minimizing the difference between the observed and the computed downstream flow top width values. Equation (8.1) being the modified form of the Muskingum model given by equation (6.1), a parameter set for a river system may be identified to best satisfy both the models. Based on the models given by equations (6.1) and (8.1) downstream discharge and flow top width prediction model for a river system can be written as

$$Q_{t+\Delta t'}^d = c_1' Q_t^{e,u,r} + c_3' Q_t^d \quad (8.2)$$

$$T_{t+\Delta t'} = \left(\left(c_1' (\sigma^{1,r} Q_t^{1,u} + \sigma^{2,r} Q_t^{2,u} + \dots + \sigma^{n,r} Q_t^{n,u}) + c_3' (\alpha_d T_t^{\beta_d}) \right) / \alpha_d \right)^{1/\beta_d} \quad (8.3)$$

For a river reach having estimated Muskingum model parameters k , $x/c_1, c_3$; shift parameter σ^p, r , and the rating parameters α_d, β_d for the downstream section, equations (8.2) and (8.3) can be defined and used to obtain downstream water discharge and flow top width estimated $\Delta t'$ time unit ahead.

Discharge and flow top width forecasting models for the Barak river system are calibrated using 241 pairs of inflow, outflow and common downstream flow top width data for the river system. Water discharge data for four gauging stations Fulertal, Tulergram, Matjuri and Badarpurghat collected from CWC, Shillong are used in forecasting downstream discharge and flow top width at Badarputghat. Observed flow top width data at Badrapurghat are obtained by using DEM and applying ArcGIS tool. The hybrid model incorporating water discharge and flow top width variables is used to obtain estimate and two hours ahead forecast for discharge and flow top width at the downstream section in the river system. To determine flow top widths at the downstream section corresponding to a set of recorded flow depths in the river system, flow top width across the downstream section is measured using the DEM. Correlation coefficients between flow top width and discharge, flow top width and depth of flow at the downstream station are found to be 0.965 and 0.935 respectively. The correlation coefficient values show that top width of flow has relationships with discharge and depth of flow at a section. The hybrid model parameters for the river system are estimated by applying genetic algorithm minimizing sum of the squatted deviation between observed and predicted flow rate and flow top width at Badrapurghat. The estimated model parameters for Barak river system are listed in Table-8.1

TABLE 8.1 Hybrid multiple inflows Muskingum model performances

Performance measures	Simulation mode		Forecasting mode	
	Discharge (m ³ /s)	Top width (m)	Discharge (m ³ /s)	Top width (m)
CORR	0.99	0.90	0.94	0.89
RMSE	139.58	148.73	132.54	158.64
CE	0.93	0.88	0.89	0.86
MAE	83.46	88.71	73.51	90.65
Model Parameters	$k=8.9\text{hrs}, x=0.113, \alpha_d=4.39, \beta_d=1.01, \sigma^{F,r}=1.11, \sigma^{T,r}=-0.077, \sigma^{M,r}=0.786$			

Superscript F, T and M represent Phulertol, Tulargram and Matijuri respectively

Using the estimated parameters downstream flow rate and downstream flow top with at Badarpurghat is predicted/estimated by using recorded discharge for four upstream stations in the river system. The estimated and 2 hours ahead predicted flow rate and flow top at Badrapurgaht are shown in figure 8.1 and 8.2. Model performances both in simulation and forecasting mode measured using statistical criteria are given in table 8.1. The results obtained show that performances of the hybrid model in forecasting flow top width and flow rate at Badarpurghat by using upstream flow rates is satisfactory and the model can be used to forecast the downstream flow conditions on the basis flow information received for a number of upstream stations in the river system. It may be mentioned here that the flow top width prediction model allows directly predicting the downstream possible water spread area in a river system in advance on the basis of upstream flow records and is useful in issuing flood warning and mitigating flood damages.

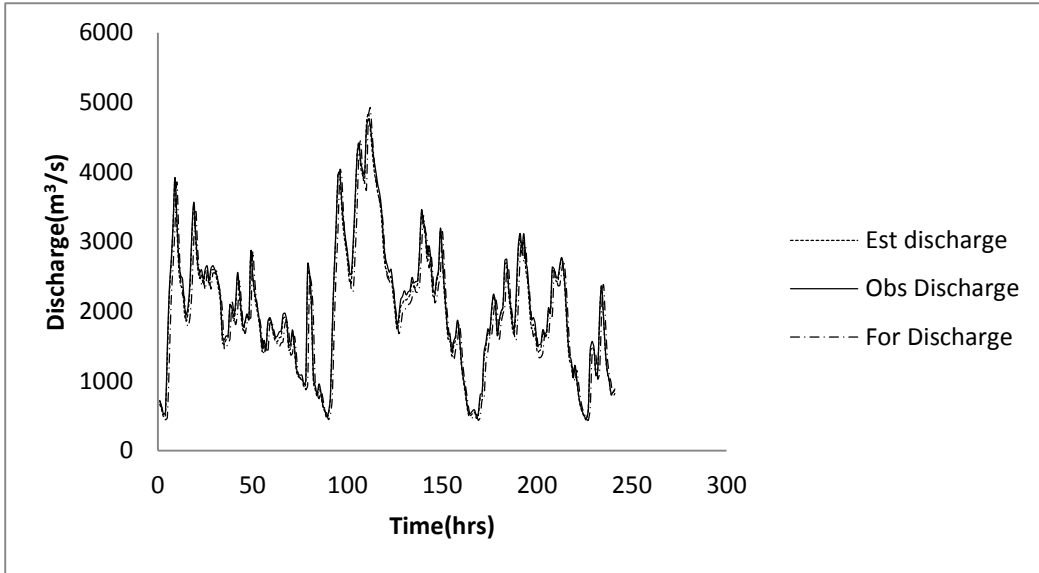

FIGURE 8.1 Observed, estimated and 2 hours ahead forecasts of downstream flow rates at Badarpurghat

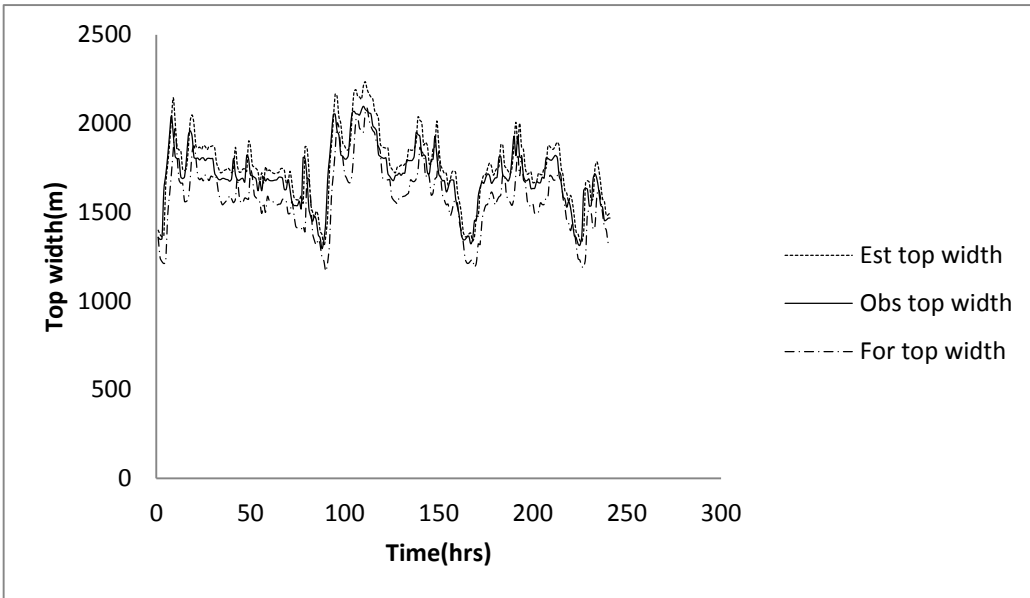

FIGURE 8.2 Observed, estimated and 2 hours ahead forecasts of downstream flow top width at Badarpurghat

9.0 Conclusions

In the present study attempt has been made to determine the extent of flow regulations required in the upstream catchments to have safe flow at important downstream damage locations in the river system in Barak valley. There are a number of gauged and ungauged catchments in the study area and downstream flow simulation model incorporating flows from all the upstream gauged and ungauged catchments have been developed for the river system. To determine the existing flow capacity of the sections in the tributary river systems as well as in the main river the sections are surveyed at a regular interval and at all critical sections along a river course and the required channel parameters and other sectional details such as flow area, top width etc are determined/computed. Expected maximum rainfall intensity for different return periods for the study area is obtained by applying L-moment techniques for the homogeneous zone identified by applying fuzzy C-means based clustering techniques.

Three flood events considering availability of rainfall records in the study area are selected and used to conduct flood movement analysis for the river system. Stage-discharge relationships for all gauging stations are developed applying regression technique and are used to express the flow depths measured at a gauging station in terms of the discharge value. Flow contributions from the ungauged catchments are obtained by using GIUH approach. Digital elevation model, stream network and slope map for the important catchments in the study area are developed using GIS technique; the stream networks are ordered using Strahler stream ordering law. Important morphological parameters for the tributary river systems required for developing the GIUH models are derived using the DEM, stream network, slope map and data obtained by direct field measurements. The IUHs obtained for the catchments are lagged using s-curve technique to derive 1-hour unit hydrograph. Contributions from the important ungauged catchments are determined by using 1-hour unit hydrograph for the catchments and the rainfall excess for the storm events during the selected flood periods. Flow contributions from the gauged and ungauged catchments are integrated using equivalent inflow for a number of upstream catchments as applicable to the river networks in the

study area. Sediment flow simulation model for the river system are developed using the sediment concentration and sediment discharge data collected for the river system. The model is used to assess the relative contributions of the catchments in sediment load in the river reaches. Downstream flow rate and flow top width forecasting models have been developed for the river system that can be applied to forecast downstream flow conditions well in advance on the basis of upstream flow rates recorded at several upstream sections. Linear Programming model is formulated for the river networks having outflow at Annapurnaghat and Badarpurghat to determine effects of upstream flows on the downstream flows. The model is applied for two cases: (i) when upstream flows from the major ungauged catchments are regulated (ii) when flows from all upstream catchments are regulated. The effects of climate change on the flow rates are incorporated in the LP model and for the changed climatic conditions flow controls required in all major catchments upstream of the potential damage sections at Annapurnaghat and Badarpurghat are evaluated. The study shows that

1) For the river system in the study area flow from the Jiri catchment has the minimum impact and the flows from the Dholai catchment has the most significant impact on the flood flow at Annapuranghat computed in terms of reductions in the peak flow rates. The percentage reduction in the peak flow rate that can be achieved by controlling flows from any one of the upstream catchments in the river system may not be sufficient in keeping flood flow rate at Annapurnaghat below safe limit. The study further show that the most significant reduction in the peak flow rate at Annapurnaghat is obtained by controlling flows from the catchments of Dholai and Mainerkhal together.

In the case of Badarpurghat flow from the catchment of Matijuri is found to have maximum influence on the peak flow rate at Badarpurghat and effect of Mainerkhal is found to be the least among all the tributary flows considered in the study. It is further revealed that significant improvements in terms of reduction in peak flood flow rates at Badrapurghat can be achieved by controlling flows either from Matijuri and Jatinga or Matijuri and Ghagra catchments as demonstrated by the study

results. It may be mentioned here that the degree of flood peak reduction achievable is dependent on the degree of flow control implemented at the identified upstream single/dual catchments. The study indicates the importance of the upstream sub catchments in controlling flood damages in the potential downstream locations and the requirement of storage facilities in the said upstream catchments for achieving the desired effects on the downstream locations need to be further estimated/evaluated

- 2) Assessment of flow controls in more than two upstream catchments show that safe flow rates at the important downstream stations can be maintained by partial regulation of flows from the upstream catchments. The study conducted to assess improvements in flood flow by controlling only the upstream ungauged catchments shows that a set of flow sequences for the regulated unaguged catchments Jiri, Chiri and Madhura with peak flow rates 1434, 1122, 1083 cumecs respectively and peak flow rates for the unregulated gauged catchments/stations Fulertal, Dholai, Maniarkhal as 5266, 404 and 673 cumecs respectively resulted safe flow at Annapurnaghat close to the critical limit. Also it can be concluded from the study that peak flow rates less than 1120.32, 258.54, 253.13, 240.11, 229.01, 5296,267,584,1826 cumecs respectively for the catchments/stations Jiri, Chiri, Madhura, Jatinga & Ghagra, Fulertal, Dholai, Maniarkhal and Matijuri respectively creates safe flow at Badarpurghat as well as at Annapurnaghat with flow rates for both the sections close to the respective safe flow limit. The model generated peak flow rates for the upstream sections resulting safe flow at the downstream stations close to the danger limit is important as it indicates minimum possible storages in the upstream catchments and exercising minimum possible flow controls for the catchments to have safe flow at the downstream stations. The results obtained in the study are based on the peak flow rates for the catchments, time to peak flow are not considered in the model. The results give an idea about the maximum possible outflow rates for the selected catchments and the actual requirements of storages in the individual catchments may be further estimated on the basis of the present findings.

- 3) The study shows that substantial improvements in the flood flow rate at the downstream stations Annapurnaghat and Badarpurghat can be expected by controlling flows in the upstream catchments. As indicated in the results given in the tables 6.19 it is seen that when all upstream catchments have some degree of control measures it results to downstream peak flow rates much below the safe limit at Badarpurghat and also at Annapurnaghat. In this case though substantial reduction in the flood flow rate at the downstream stations can be obtained by controlling flows in all upstream catchments as indicated in the results this option may not be much preferable considering financial and other implications.
- 4) The study conducted to assess impacts of the climate change quantifies the requirement for additional storages in the respective catchments. The study shows that when river discharges increase by 10-20% due to change in the climate having almost same level of flow from the major upstream catchments as indicated by the respective peak flow rates given in table 6.19 safe flood flow both at Annapurnaghat and Badarpurghat well below the danger level can be obtained. However, in that case storage requirements for the selected upstream catchments will be higher compared to the storage requirements for no changes in the climate and no increment in the river discharges.
- 5) The sediment flow simulation study conducted using sediment data available from CWC show that the relative contribution of sediment from the Matijuri catchments is more compared to the other catchments considered in the study. It is found that for no sediment flow from the Matijuri catchments the sediment load at Badarpurghat reduces by 10.46 % and the peak sediment concentration decreases by 12.36%. In the case of Dholai sub catchment the improvement in sediment load at Badarpurghat is around 9.23% and reduction in peak sediment concentration rate is 9.25%.
- 6) The study shows that water discharge-flow top width hybrid model is useful in Barak river system and can be applied to forecast downstream flow rates and flow top width on the basis of flow rates recorded at several upstream sections.

Direct prediction of flow top width at a section by using current upstream flow rates and simple channel system parameters is important as the predicted flow top width gives advance information on the possible spread of flow, the risk of flooding and the extent of flooding at the downstream section.

7. Based on the survey works, field trips and laboratory works conducted to assess existing flow capacity of the channel systems, functioning of the sluice gates in the districts of Cachar, Karimganj and Hailakandi and status of existing embankments along the river courses etc. the following observations/recommendations forwarded that may be considered for further study and / implementation for improving overall flood condition in the valley

Karimganj District:

A. River Kushiyara

- (i) On field investigation, it has been observed that there is severe erosion on the left bank of river Kushiyara at Haritkar Jobinpur, Bakarshal (near B.O.P camp in karimganj town area), Deopur, Chandsrikona, Shenulbag, Jagannathi, Sadanashi, Lxmibazar area and is causing economic losses to the local populace. Suitable anti erosion measures may be under taken to protect these places from erosions.
- (ii) There is a problem of water logging in Karimganj town which is mainly during high stages in the river Kushiyara. During high stages in the river Kushiyara surface drainage is retarded with occasional back flow from the river Kushiyara. An additional sluice gate preferably in areas near Chanbazar may help much in regulating the accumulated water as well as in protecting the greater Karimganj town area from drainage congestion.

On executing the above mentioned works a vast area of approximately equal to 200 sq km including a total population of 3.00 lakhs in Karimganj district will be benefitted. Also National Highway NH-44, NH-154, Assam- Tripura Railway Line, Border Outpost (BOP) CAMP at Indo-Bangladesh Border and many other Government and public utilities will be saved from flood inundation and erosion.

B. River Longai

- (i) A vast area in Karimganj district is inundated by the river Longai. Though, there are embankments at places along the river course the existing embankment needs further raising and strengthening to protect the villages along the river course namely, Morangaon and Koncharchat, Ptherkandi Bazar area, Village Muraure, Bahadurpur, Salepur, Teoghoari, Charrarbazar etc on right bank of river Longai and villages namely Nalibari, Katebari, Kolkolighat, Khankar, Muraureetc on left bank of river Longai along with anti-erosion works.
- (ii) To reduce flood related damages and water logging in Nilambazar and Nilambazar-Krishnanagar area in southern part of Karimganj District additional sluice gates are required to regulate the flows. The new sluice gate may suitably be installed at P.W.D Colony, Kalibari area, at village Abdullapur and at Ganghai area to get rid of water logging in southern Karimganj District.
- (iii) One number of sluice gate over Churia Jhumjhumi Channel near village Muraure in Karimganj district needs to be modernized and reconstructed for proper functioning.

On completion of the above works, the total urban and rural area of approximately equal to 1000 sq km including important National Highway NH-44, Assam- Tripura Railway line , vast cultivable land and many other Government and public utilities will be saved from flooding. A total population of approximately 3.00 lakhs is expected to be benefitted.

Hailakandi District:

A vast area in the Hailakandi district is inundated by river Katakhal. Most of the existing sluice gates are not fully functional and are making the flood problem further complicated. The following improvement works is necessary and may be taken up to improve the flood conditions in Hailakandi district.

1) IMPROVENT IN THE FUNCTIONING OF SLUICE GATES

POLA SLUICE:- Located on Pola channel, draining runoff to the R/ Borak. It has 4 nos shutters. It is partially functional. To make it fully functional, it needs repairing of 2 no shutters including guide channels and as well as

raising and strengthening of guide bund and recouplement of river side apron etc.

HATIA DIVERSION SLUICE: - Located on Dhaleswari river, draining run off to river Dhaleswari from the Bakrihaor area. It has 4 nos of shutters and is partly functional. To make it fully functional, it needs repair of 2 no shutters including all guide channels.

HATIA SLUICE: - Located on R/ Dhaleswari. It has single shutter. It is non functional at present. Its shutter is fully damaged including guide channel, counter weight is also not existing and is fully non functional.

LALATOL SLUICE: - Located on R/ Katakhal. It has 2 nos shutters. It is partially functional. Repairing of Shutters is necessary to make it functional.

II) Raising and Strengthening of Existing embankments:

The river katakhal is inundating a vast area in Hailakandi District almost every year. To save these areas from flood ingrising and strengthening work of existing dyke along the river course is necessary. Raising and strengthening work of the dyke along left bank of the river katakhal from Matijuri bridge to Narainpurbazar will be useful in saving vast areas from flood inundation and may be taken up on urgent basis.

- III) In Ashia Beel area waterlogging is caused due to blockage in JitaNadi creating difficulties, losses and flood congestion. Flow capacity of the watercourse is reduced severely due to several factors. Clearing of the blockages in the channel course to improve draining of surface flow into the river Dhaleshwari will be helpful in improving the overall flood condition in the area.

Cachar District:

- I) There is severe drainage congestion in the southern part of Silcharcity and in the adjoining areas mainly due to reduced flow carrying capacity of the channel systems. The Rangirkhari channel is the major carrier channel with

outfall at the River Ghagra and is draining most parts of the Silchar city as well as Mahisabeel of Bethukandi area. Flow carrying capacity of the Rangirkahri channel needs to be improved by removing encroachments etc. for efficient drainage. Further, the channel course may be defined and made fixed to avoid future encroachment and modification of flow area of the important channel. There is a sluice gate in the channel with outfall at Ghagra which is not sufficient for removal of the drained water into the Ghagrariver efficiently; an additional sluice gate with pupping facility may be installed at a suitable location to enhance removal of water drained by the channel. Installation of additional sluice gate in the Rangirkhari channel will be helpful in discharge in huge volume of accumulated water thereby clearing drainage congestion in the southern part of Silchar city as well as in the adjoining areas.

- II) Construction of sluice gate at Kandhigram area along left bank of river Barak on the dyke from Badarpur to Bhanga is required to improve drainage congestion in a area of approximately 5.0 sq km.

- III) Raising and strengthening of embankment along Sonai River is required at places. Flood management works to protect the village Nandigram on the left bank of river Sonai; raising and strengthening of embankments from Berabak to Kagdohr will save approximately 800 hectres of land areas and more than 2.0 lakhs of people will be benefitted apart from saving the National highway connecting Silchar to Aizwal.

In the case of Sonai River as given there is no embankment protection on the right side of the bank approximately for a length of 3 km around 50 km away from the confluence with the river Barak and causing flood damages. The heights of the existing embankment on the left side is varying from 1.00-2.70 m. Embankment of heights 1.5-2.0 m on right side is necessary to protect agricultural land in these area.

Jiri and Chiri river are two rivers joining the main river Barak in the upper reaches have no embankment along the river reaches. Considering that the rivers are in the upper reaches and have no major flooding effects embankment protection may not be considered with top priority.

In Badri river system embankment protection may be provided on the right as well as left side of the river for a length of approximately 7.0 m with a height of 2.0 m to have flood protection.

A vast area in Karimganj district is inundated by the river Longai. Existing embankments need further raising and strengthening to protect the villages along the river course namely, Morangaon and Konchargethat, Patherkhandi Bazar area, Bahadpur, Salepur, Charrarbazar on the right bank and villages Nalibari, katebari, kolkolighat etc on the left bank. Existing embankment for a length of around 30 km on left and right side of the river from 50 to 80 km away from the Bangladesh border need to be raised to a height of 2.0-2.5 m to give enhanced protection for these areas.

The dyke existing from Matijuri to Ratanpurghat in Hailakandi district is having an average height of approximately 1.00 m and width of the dyke is less than 2.00 m. The average height of the dyke from Ratanpurghat to Mohanpur is approximately 2.0m with width 2.0m. The last portion of the dyke along Katakhal river from Mohanpur to confluence with Matijuri is relatively in a good condition though there are breaches at three places: (i) around 1.5 km u/s of Mohanpur bazar: breach length around 20.0m (ii) approximately 500 m d/s of the bazar (breach length = 35 m approx) and (iii) 1.5 km d/s of the bazar (breach length 30.0). Repairing of the existing dykes at the above mentioned places and raising of the dyke height to approximately 2.5 m is required to prevent flooding by the Katakhal river.

10.0 Study Findings- Implications & Recommendations

Broad objectives of the project work is to study and develop a comprehensive plan for mitigating flood damages in Barak valley in south Assam including effects of climate change. Different studies conducted to achieve the set goals are described below:

(I) Assessment of existing flow capacity of different channel sections:

To assess existing flow capacity of channel systems a detailed survey of channel systems in the study area has been undertaken. The main channel reach as well as tributary channel systems have been surveyed. Existing flow area details in terms of flow area, maximum flow top width, maximum depth, average depth etc. for all major channel systems have been included in the report (section-2). More than one thousand kilometre of river course in the valley have been covered. Based on the existing status of the channels systems some suggestions to improve local flood conditions have been identified and incorporated in the report (section-9).

(II) (a & b) : Status of existing embankments and sluice gates:

On the basis of field examination status of the existing embankment along the main river and the tributary system have been assessed. Details of existing embankment in terms of heights, distance from the mid water course etc have measured and the details are given in Table-2.1-2.11. Gap positions in the existing embankment and raising and strengthening of the embankments for improving drainage conditions have been reported in the study. Status of the existing sluice gate in the study area is reported in Table-2.12. Based on the status of the existing embankments and sluice gates improvement in the functioning of the embankment and sluice gates are suggested in the report, section 9.0. The solutions are intended to improve local drainage conditions. To have a basin wide long term solutions impact of all major channels flows on the downstream flows have been

evaluated applying simulation and optimization models as described in next few lines.

(iii) Improvement works in lateral channels.....

Improvement works required in the lateral channel works have been identified on the basis of survey works and through simulation study. Flow generation capacity for the subcatchments have been assessed using hydrograph technique (Table-5.3.....). Runoff generation capacity for the subwatershed for unit rainfall excess has been reported in terms of unit hydrograph derived using GIUH approach (Sec-5.0). Flood flow simulation model for the river system involving the ungauged and gauged catchments have been developed (Sec-6.1). Downstream flow rates for different combination of upstream flows have been computed. Basin wide Long term solution in terms of temporary detention of waters in the sub catchments have been worked out for different scenarios including effects of climate change and also short term solutions for improvement in the flood conditions by controlling the lateral channel are found out and are given in the report. (Section 6.1, Table-6.2-6.12). Optimization model results to assess relative impacts of the tributary flows for different combination of upstream flows in terms of reduction in peak flow rate, reduction of discharge creating safe flow for are listed in Table-6.14-6.17. The results indicate the various strategies that are helpful in achieving valley wide long terms solution for reducing flood damages. Various alternative control strategies have been identified that create safe flow at the important downstream locations. Selection of the best alternative would require further study to examine technical and financial feasibility of the options indicated in the study report.

(IV) On the basis of available data sets sediment flow simulation model for the river system have been formulated (Section-7.0). Models to assess impact of sediment flow from upstream catchments on the downstream sediment flow rates have been developed (Sec-7.0). Impact of upstream sediment

flow on the downstream sediment flow rate as obtained in the study is given in Table-7.3. The result is useful in taking anti erosion measures in the upstream catchments

- (V) For improved flood forecasting in the river system a hybrid model for the river system has been developed (Sec-8.0). The model forecasts downstream discharge and flow top width 2 hrs ahead on the basis of known upstream flows in the river system (section -8). The prediction of flow top width gives an estimate for the possible inundation area and is useful in taking preventive measures against flood losses

Study Results: Usefulness & Recommendations

Usefulness of the results obtained for different parts of the present study along with major implications and Recommendations are presented below:

1. Determination of Existing Flow capacity of the channel systems:

Existing flow capacity for the main channel from Lakhipur to Bangladesh boarder in Karimganj district and all major tributary channel courses in the study area have been surveyed. Flow section details at all critical sections and at a regular interval of 1.5-2 km have been given in the report. The results are useful to Water Resources Department and Inland Water Transport Department etc. for various planning works. Water Resources Department may use sectional profiles in planning anti river bank erosion measures; in designing and construction of bridges across the rivers; designing of sluice gates etc for adopting flood control measures. The cross sectional details are useful to the Inland Water Transport Department in selecting navigational routes in the study

2. Hydrologic information for ungauged watersheds in the basin.

There are many ungauged watersheds in the study area for which storm runoff hydrographs information are not available. In the present study 1-hour unit hydrograph for these watersheds have been developed. These hydrographs gives an idea about the runoff generation capacity for the

watersheds and are useful to the Water Resources Department for design and planning works related to drainage, flood flow studies etc. The department may utilize the UH developed for the watersheds to generate runoff from these area corresponding to a selected rainfall event obtaining drainage patterns, volumes of runoff generated, time to peak flow, peak flow volume etc. such information is required for planning and designing of bridges, designing anti erosion measures, planning and designing flood control measures etc.

3. **Slope map, drainage map and digital elevation models:** Slope map, drainage map and digital elevation models developed for the watersheds are useful to Agricultural department and water resources, Forest, Soil Conservation department and also to the district administration for various planning works. The drainage map, slope map and digital elevation models for the watersheds are helpful to the department in planning and designing surface drainage related works. DEM can be utilized to identify low and high grounds in the study area and is useful in flood zoning works. The generated maps are basic inputs to many distributed models such as soil erosion model, flood flow model etc. Soil erosion from the catchments effect agricultural output and also adversely effect quality of the stream water. The Agricultural Department, Forest and Environment Department, Soil Conservation Department may further utilize these inputs in studying different other aspects of erosions from these catchments

4. The daily maximum expected rainfall magnitude estimated for the study area **for return periods of 10, 20,...50 years can be utilized by Water Resources, Agricultural and Forest department** for different hydrologic studies and planning works. Extreme rainfall magnitude are useful in flood/land slide hazards risk and vulnerability studies and are useful to the Department of Water Resources, Department of Forest, Environment other agencies for designing of hydraulic and other structures, in selecting alignment for roads, railways etc.

5. Integrated sediment flow simulation model results that give relative importance of the watersheds in the downstream sediment flow concentration are useful to Agricultural, Forest & Environment, Soil and Water Conservation Department in taking anti erosion measures by adopting different techniques such as Catchment treatment, soil stabilization, contour bund, etc.
6. Results of the downstream flow forecasting model applicable to the river system that directly gives the possible area of inundation is useful to Water Resources department and the Civil Administration. The model forecast gives advance warning in the form of possible area of flooding; the advance information is useful to Water Resources Deptt & Civil Administration in taking possible damage mitigation measures in advance.
7. The short term flood control measures that have been suggested on the basis of field information may be utilized by the Water Resources department for solving local flood damage problems. Based on the field visits, Laboratory works and inputs received from the Water Resources officials a number of solutions have been formulated to improve the local drainage conditions; the department may work on the proposals and implement the solutions to improve the local drainage conditions
8. The basin wide long term flood damage control measures that have been suggested in terms of maximum flow rates for the upstream catchments that create safe flow at the downstream sections are useful to the Water Resources department and the Civil Administration. The results give a number of possible solutions to obtain safe flow rates at the important downstream stations in the study area. The solutions give a complete picture of the effects of different tributary flows on the downstream flood flows. Feasibility study for these alternative solutions needs to be done in future for selecting the best possible valley wide long term solution. For each of the solutions suggested detail investigation on storage requirements in different upstream catchments, availability of necessary storage spaces in a

catchment; different alternative storage options and feasibility of creating storage space in the catchments need to be checked/evaluated along with the method of operation, if any to select the best possible valley wide solution.

The study report presents short term and long term solutions for flood damage mitigation in Barak valley, Assam. The long term valley wide solutions if implemented would provide safe flow at the important downstream locations and thereby help in mitigating flood losses across the study area. The long term solutions are cost intensive and time consuming; in the absence of valley wide solution short term measures may be implemented to improve the local drainage conditions. A number of solutions to improve local drainage in the study area have been formulated. Based on the availability of fund and if valley wide long term solution is not adopted short term solutions indicated in the report may be implemented by the Water Resources Department to mitigate flood damages in the valley.

11. References:

- [1]. J.R.M. Hosking (1990) L-moments "Analysis and Estimation of Distributions using Linear Combinations of order Statistics ", J.R. Statist. Soc. B(1990), 52, No. 1, pp. 105-124.
- [2]. Richard M. Vogel and Neil M. Fennessey "L-moment Diagram Should Replace Product Moment Diagrams", Water Resources Research, Vol. 29, No.6, Pages 1745 – 1752, (1993).
- [3]. Oli G.B. Sveinsson, Jose D. Sales, M.ASCE and Dauane C. Boes "Regional Frequency Analysis of Extreme Precipitation in North Eastern Colorado and Ford Collins Flood 1997", DOI. 10.1061/(ASCE)1084-0699(2002)7:1(49) .
- [4]. S. Safid Eslamian, Hussein Feizi "L-moments for Maximum Rainfall Analysis for an Arid region in Isfahan Province in Iran", Journal of Applied Hydrology & Climatology Vol.46 (2006) .
- [5] D.Hayward& R.T. Clarke "Relationship between rainfall, altitude & distances from the sea in the Freeton Peninsula", Sierra Leone, Hydrological Sciences Journal (2009)

- [6]. P. Satyanarayana and V. V. Srinivas "Regionalization of precipitation in data sparse areas using large scale atmospheric variables – A fuzzy clustering approach", (Journal of Hydrology 405 (2011) 462-473,
- [7] Choudhury, P., R.K. Shrivastava and S.M. Narulkar (2002)" Flood routing in river networks using equivalent inflow" J.Hydrologic Engineering, ASCE, vol. 7(6), 413-419
- [8] Choudhury, P, A. Sankarasubramanian (2009) "River Flood Forecasting Using Complementary Muskingum Rating Equations" Hydrologic Engg.(ASCE), 14(7), 745-751
- [9] Choudhury,P and B.S. Sil "Integrated water and sediment flow simulation and forecasting models for river reaches" J. Hydrology, Elsevier (doi:10.1016/j.jhydrol.2010.02.034),2010, 385, pp 313-322
- [10] Choudhury,P and N. Ullah "*Flow top width simulation and forecasting models for a river system using hybrid multiple inflows Muskingum model.*" WATER SA,2014 , 40 (3), pp 1-9

APPENDIX:-A

DESIGN OF SLUICE GATES: Near Charbazar (Karimganj)

.Effective catchment Area=2332.00 hectres

Impervious factor

Intensity of rainfall =188 mm/day

HFL, R/S= 14.87 m

HFL, C/S=14.30 m

NFL of the channel=11.32 m

Average period of back flow= 10 days

Silt factor=0.38

Bearing capacity =130 kn/m²

Angle of repose of soil=30⁰

Hydraulic gradient for the dam over sluice =5:1

Angle of surcharge in using walls etc=2:1= 26.56⁰

Co efficient of friction =0.65 (assumes)

Calculation of the size of the opening:

Using rational formula the discharge across the channel is

$$Q = \frac{AIR}{360} \times K$$

$$= \frac{2332 \times 0.6 \times 7.83}{360} \times 0.6$$

$$= 18.26 \text{ cumec}$$

A= catchment area in hectre

D=Imperviousness factor=0.6

R=Intesity of Rainfall= 188/24=7.3mm/hour

K=runoff co efficient = 0.6 for clayey soil, stiff and bare

As the sluice will be closed for a period of 7 days and it is proposed to drainout the water in next 05 days and hence design discharge of the sluice gate is

$$Q_D = \frac{Q \times 7}{5} = \frac{18.26 \times 7}{5} = 25.26 \text{ cumec}$$

$$Q_D = C_d a \sqrt{2gh}$$

$$a = \frac{Q_d}{(C_d \sqrt{2gh})} \quad \text{assuming head difference } h=0.6\text{m}$$

$$a = \frac{(25.56)}{(0.03 \sqrt{2 \times 9.81 \times 0.60})}$$

$$a = 11.83 \text{ m}^2$$

Thus the opening may be required is around 12 m² and the size of the opening may be taken 2 m x 3m with area of the proposed opening 2x2mx3m=12 m²

Design discharge through the opening= $0.63 \times 12 \times \sqrt{2 \times 9.81 \times 0.60}$)=25.93 m³/s

Hydraulic Calculations for various flow conditions

HFL, C/S=14.30

Corresponding R/S water level with full discharge= 14.30-0.6=13.70m

Assuming 0.5 m retrogression, R/S water level=13.70-0.50=13.20m

Assuming 0.5m afflux, c/s water level=14.30+0.5=14.80m

Velocity of flow through the opening= $v = \frac{Q_D}{Q_a} = \frac{25.93}{12} = 2.16 \text{ m/s}$

Loss of head at the entry = $0.5 \frac{v^2}{2g} = 0.5 \cdot \frac{2.16^2}{2 \times 9.82} = 0.12\text{m}$

Total energy just d/s of gate=14.80-0.12=14.68m

R/S total energy level=13.20 m

Head loss=14.68-13.20=1.48m

Discharge intensity= $q = \frac{Q_D}{\text{Water Way}} = \frac{25.93}{6} = 4.32 \text{ cumec/m}$

During Normal Flow level:

C/S=11.32m

R/S water level corresponding to 0.6 m head difference

=11.32-0.6=10.72m

Total energy level just downstream of the gate=11.32+0.3-0.12=11.50m, considering 0.3m afflux.

R/S TEL=10.72m

Head loss= 11.50-10.72=0.78m

Based on the above computed parameters

Cistern length =11.00 m is taken and side slope of the glacis as 1:3, depth of the cistern=0.90 m

Energy dissipation Device and Splay

C/S splay: at 29.00°

R/S Splay: at 9.5°

Total Length of the floor=60.00 m with following details:

C/S Floor: = 3.00m

Barrel portion= 37.50 m

Gate portion= 0.60 m

u/s slope of glacis= 2.70 m

Cistern = 10.0m

d/s slope of glacis = 2.70 m

R/S floor = 3.0m

Barrel: Opening: Clear size of the opening= $2 \times 3.0 \text{ m} \times 2.0 \text{ m}$

Thickness of top and bottom slab=0.4 m

Thickness of side walls and partition walls=0.4 m

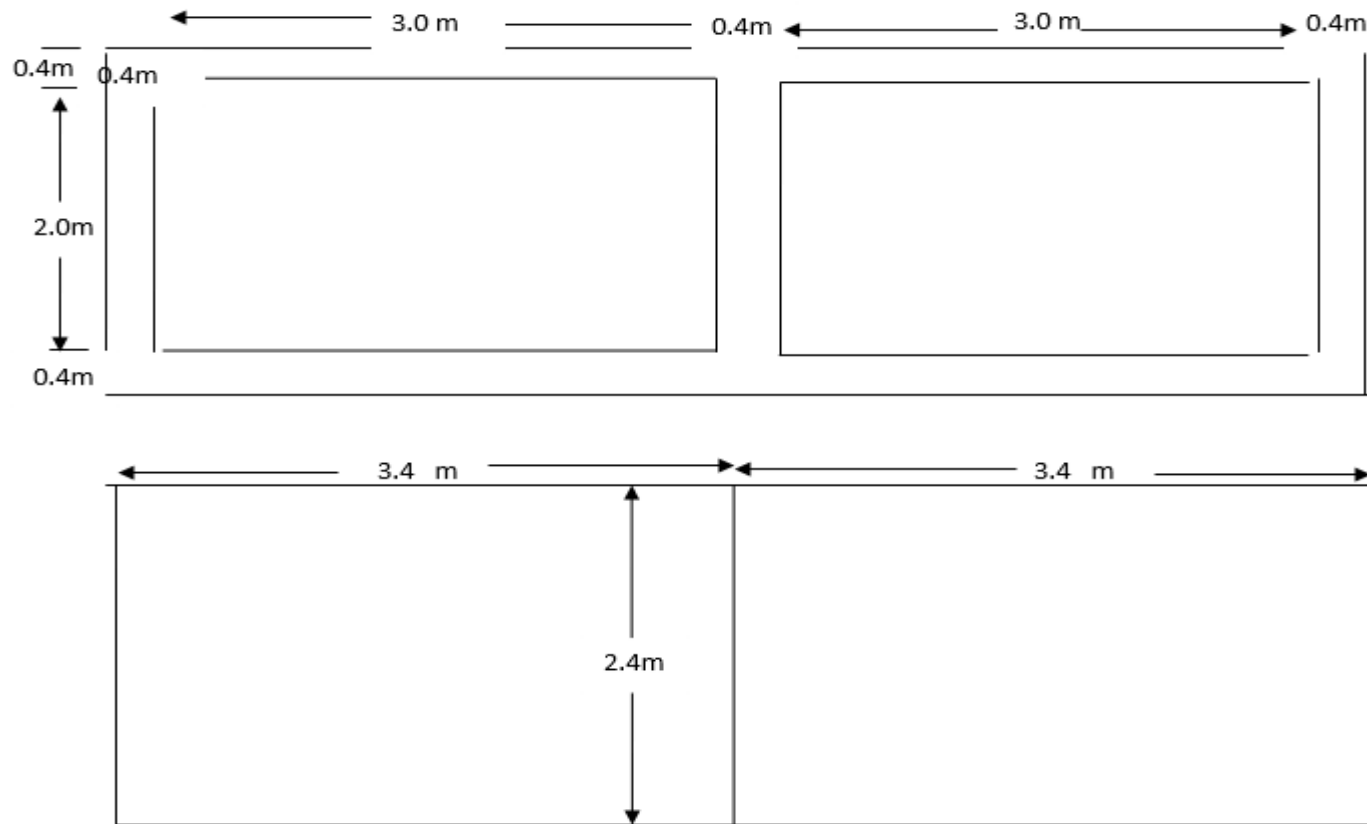

Barrel: Openings

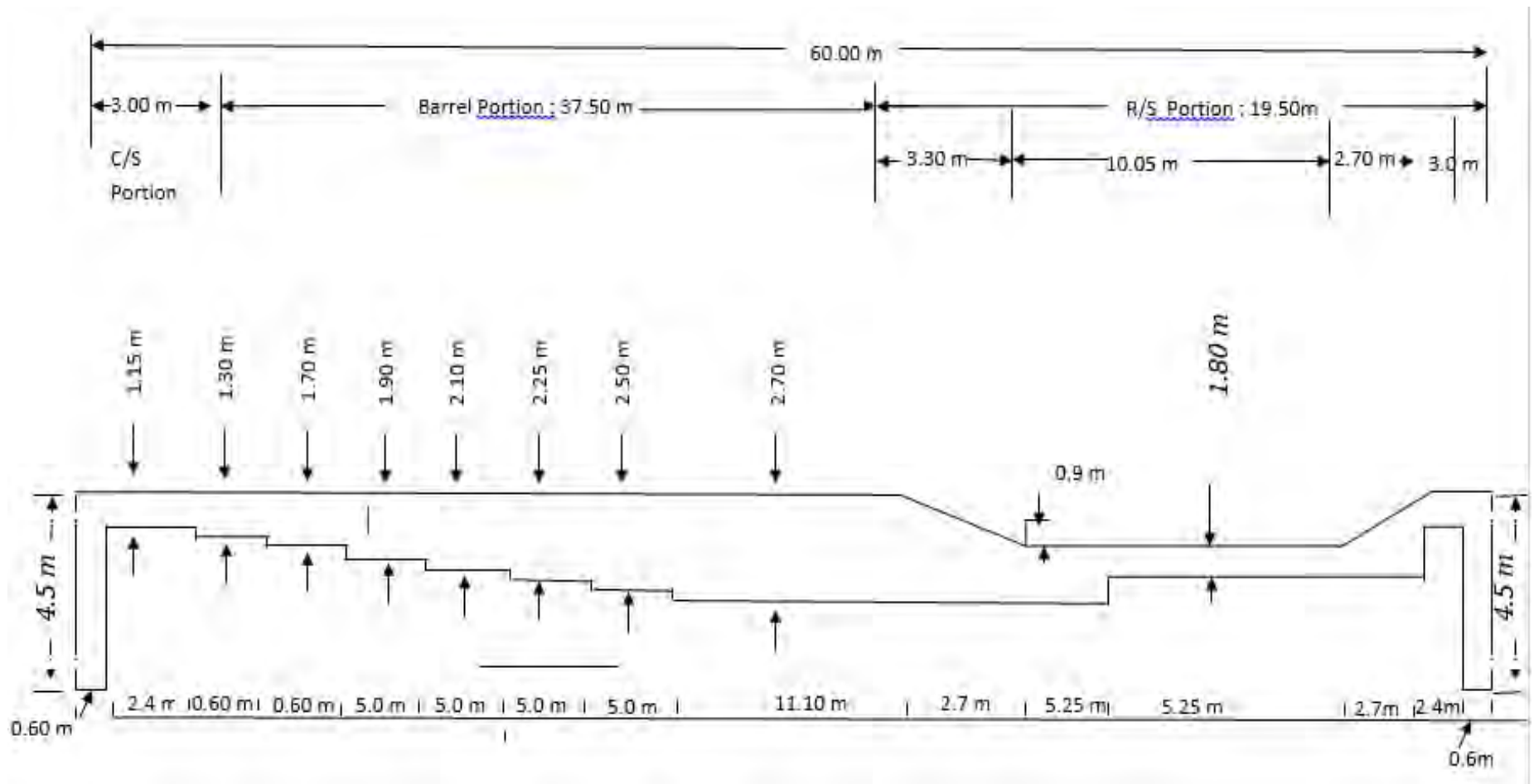

Arrangement of Gravity Floor etc. on the structures

Details of proposed SLUICE GATES: Kalibari Area (Nilambazar)

.Effective catchment Area=2432.00 hectres

Impervious factor

Intensity of rainfall =188 mm/day

HFL, R/S= 14.67 m

HFL, C/S=14.25 m

NFL of the channel=11.30 m

Average period of back flow= 7 days

Silt factor=0.38

Bearing capacity =130 kn/m²

Angle of repose of soil=30⁰

Hydraulic gradient for the dam over sluice =511

Angle of surcharge in using walls etc= 26.56⁰

Co efficient of friction =0.65 (assumes)

Calculation of the size of the opening:

Using rational formula the discharge across the channel is

$$Q = \frac{AIR}{360} x K$$

$$= \frac{2432x0.6x7.83}{360} x 0.6$$

$$=19.11 \text{ cumec}$$

A= catchment area in hectre

D=Imperviousness factor=0.6

R=Intesity of Rainfall= 188/24=7.3mm/hour

K=runoff co efficient = 0.6 for clayey soil, stiff and bare

As the sluice will be closed for a period of 6 days and it is proposed to drainout the water in next 05 days and hence design discharge of the sluice gate is

$$Q_D = \frac{Q \times 7}{5} = \frac{19.00 \times 6}{5} = 22.80 \text{ cumec}$$

$$Q_D = C_d a \sqrt{2gh}$$

$$a = \frac{Q_d}{(C_d \sqrt{2gh})} \quad \text{assuming head difference } h=0.6\text{m}$$

$$a = \frac{(22.80)}{(0.03 \sqrt{2 \times 9.81 \times 0.60})}$$

$$a = 22.70 \text{ m}^2$$

Thus the opening may be required is around 24 m² and the size of the opening may be taken 2.8 m x 2.8 m with area of the proposed opening 3x2.8 mx2.8 m=23.52 m²

Design discharge through the opening=0.63x24x√(2x9.81x0.60)=50.87 m³/s

Hydraulic Calculations for various flow conditions

HFL, C/S=14.30

Corresponding R/S water level with full discharge= 14.67-0.6=14.07m

Assuming 0.5 m retrogression, R/S water level=14.07-0.50=13.57m

Assuming 0.5m afflux, c/s water level=14.25+0.5=14.65m

Velocity of flow through the opening= $v = \frac{Q_D}{Q_a} = \frac{51.87}{24} = 2.16 \text{ m/s}$

Loss of head at the entry = $0.5 \frac{v^2}{2g} = 0.5 \cdot \frac{2.16^2}{2 \times 9.82} = 0.12\text{m}$

Total energy just d/s of gate=14.80-0.12=14.68m

R/S total energy level=13.57 m

Head loss=14.68-13.57=1.11m

Discharge intensity= $q = \frac{Q_D}{\text{Water Way}} = \frac{50.83}{(2.8*3)} = 6.05 \text{ cumec/m}$

During Normal Flow level:

C/S=11.32m

R/S water level corresponding to 0.6 m head difference

=11.32-0.6=10.72m

Total energy level just downstream of the gate=11.32+0.3-0.12=11.50m, considering 0.3m afflux.

R/S TEL=10.72m

Head loss= 11.50-10.72=0.78m

Based on the above computed parameters

Cistern length =11.00 m is taken and side slope of the glacis as 1:3, depth of the cistern=0.90 m

Energy dissipation Device and Splay

C/S splay: at 29.00°

R/S Splay: at 9.5°

Total Length of the floor=67.00 m with following details:

C/S Floor: = 5.00m

Barrel portion= 40.50 m

Gate portion= 0.60 m

u/s slope of glacis= 2.70 m

Cistern = 10.0m

d/s slope of glacis = 2.70 m

R/S floor = 5.0m

Barrel: Opening: Clear size of the opening= $3 \times 2.80\text{m} \times 2.80\text{m}$

Thickness of top and bottom slab=0.4 m

Thickness of side walls and partition walls=0.4 m

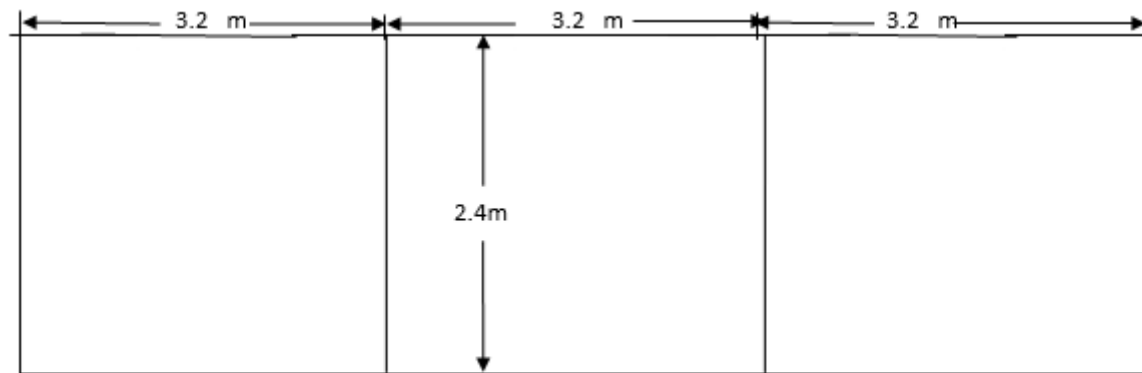
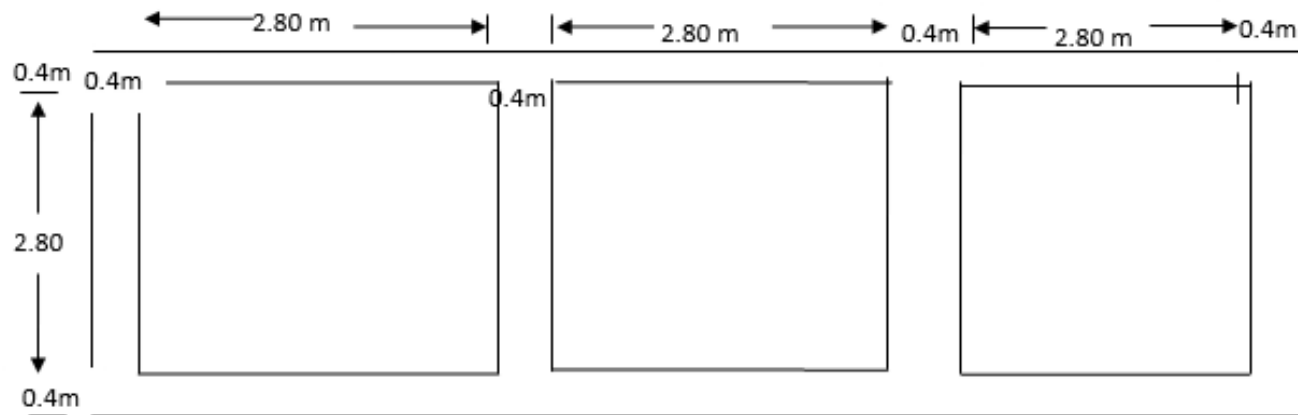

Barrel: Openings

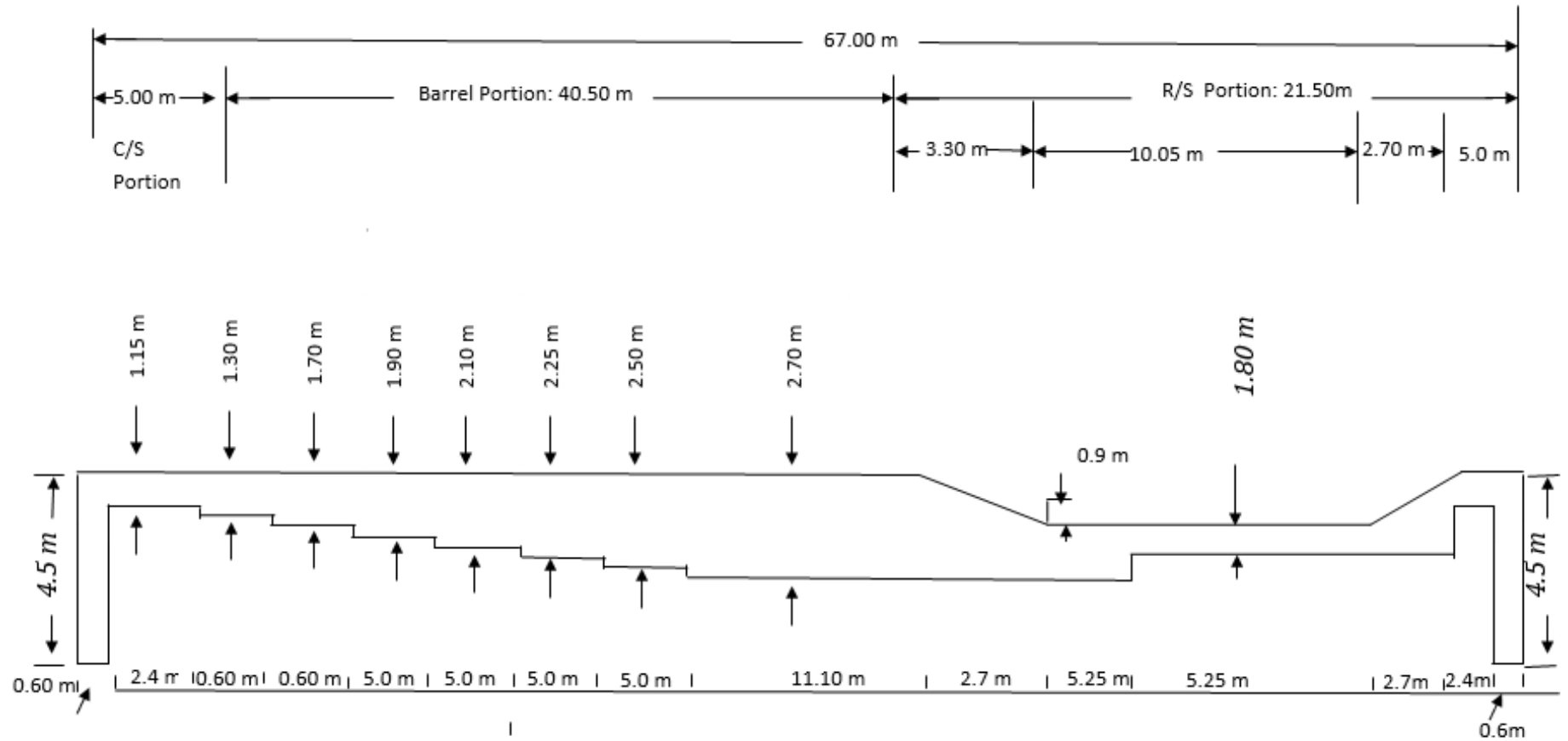

Arrangement of Gravity Floor etc. on the structures

Details of proposed SLUICE GATES: Kandigram

catchment Area=2591.00 hectres

egffective catchment Area=2398.00 hectre

Impervious factor

Intensity of rainfall =188 mm/day

HFL, R/S= 22.97 m

HFL, C/S=22.30 m

NFL of the channel=18.845 m

Average period of back flow= 7 days

Silt factor=0.38

Bearing capacity =130 kn/m²

Angle of repose of soil=30⁰

Hydraulic gradient for the dam over sluice =5:1

Angle of surcharge in using walls etc= 2:1 =26.56⁰

Co efficient of friction =0.65 (assumes)

Calculation of the size of the opening:

Using rational formula the discharge across the channel is

$$Q = \frac{AIR}{360} \times K$$

$$= \frac{2332 \times 0.6 \times 7.83}{360} \times 0.6$$

$$= 18.26 \text{ cumec}$$

A= catchment area in hectre

D=Imperviousness factor=0.6

R=Intensity of Rainfall= 188/24=7.3mm/hour

K=runoff co efficient = 0.6 for clayey soil, stiff and bare

As the sluice will be closed for a period of 7 days and it is proposed to drainout the water in next 05 days and hence design discharge of the sluice gate is

$$Q_D = \frac{Q \times 7}{5} = \frac{18.26 \times 6}{5} = 25.56 \text{ cumec}$$

$$Q_D = C_d a \sqrt{2gh}$$

$$a = \frac{Q_d}{(C_d \sqrt{2gh})} \quad \text{assuming head difference } h=0.6\text{m}$$

$$a = \frac{(25.56)}{(0.03 \sqrt{2 \times 9.81 \times 0.60})}$$

$$a = 11.83 \text{ m}^2$$

Thus the opening may be required is around 12 m² and the size of the opening may be taken 2 m x 3m with area of the proposed opening 2x2mx3m=12 m²

Design discharge through the opening= $0.63 \times 12 \times \sqrt{2 \times 9.81 \times 0.60}$)=25.93 m³/s

Hydraulic Calculations for various flow conditions

HFL, C/S=14.30

Corresponding R/S water level with full discharge= 14.30-0.6=13.70m

Assuming 0.5 m retrogression, R/S water level=13.70-0.50=13.20m

Assuming 0.5m afflux, c/s water level=14.30+0.5=14.80m

Velocity of flow through the opening= $v = \frac{Q_D}{Q_a} = \frac{25.93}{12} = 2.16 \text{ m/s}$

Loss of head at the entry = $0.5 \frac{v^2}{2g} = 0.5 \cdot \frac{2.16^2}{2 \times 9.82} = 0.12\text{m}$

Total energy just d/s of gate=14.80-0.12=14.68m

R/S total energy level=13.20 m

Head loss=14.68-13.20=1.48m

Discharge intensity= $q = \frac{Q_D}{\text{Water Way}} = \frac{25.93}{6} = 4.32 \text{ cumec/m}$

During Normal Flow level:

C/S=11.32m

R/S water level corresponding to 0.6 m head difference

=11.32-0.6=10.72m

Total energy level just downstream of the gate=11.32+0.3-0.12=11.50m, considering 0.3m afflux.

R/S TEL=10.72m

Head loss= 11.50-10.72=0.78m

Based on the above computed parameters

Cistern length =11.00 m is taken and side slope of the glacis as 1:3, depth of the cistern=0.90 m

Energy dissipation Device and Splay

C/S splay: at 29.00°

R/S Splay: at 9.5°

Total Length of the floor=60.00 m with following details:

C/S Floor: = 3.00m

Barrel portion= 37.50 m

Gate portion= 0.60 m

u/s slope of glacis= 2.70 m

Cistern = 10.0m

d/s slope of glacis = 2.70 m

R/S floor = 3.0m

Barrel: Opening: Clear size of the opening= 2x3.0mx2.0m

Thickness of top and bottom slab=0.4 m

Thickness of side walls and partition walls=0.4 m

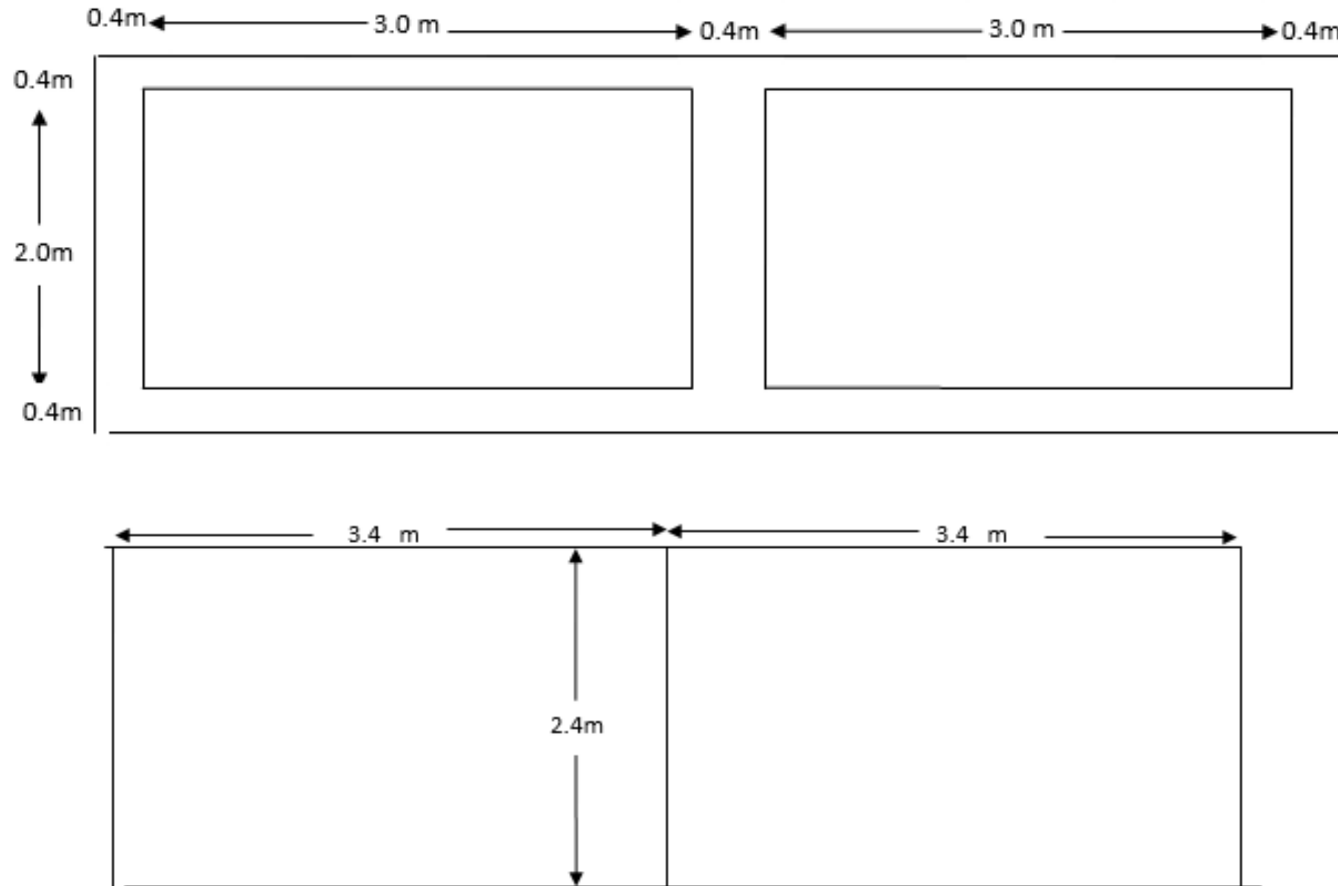

Barrel: opening

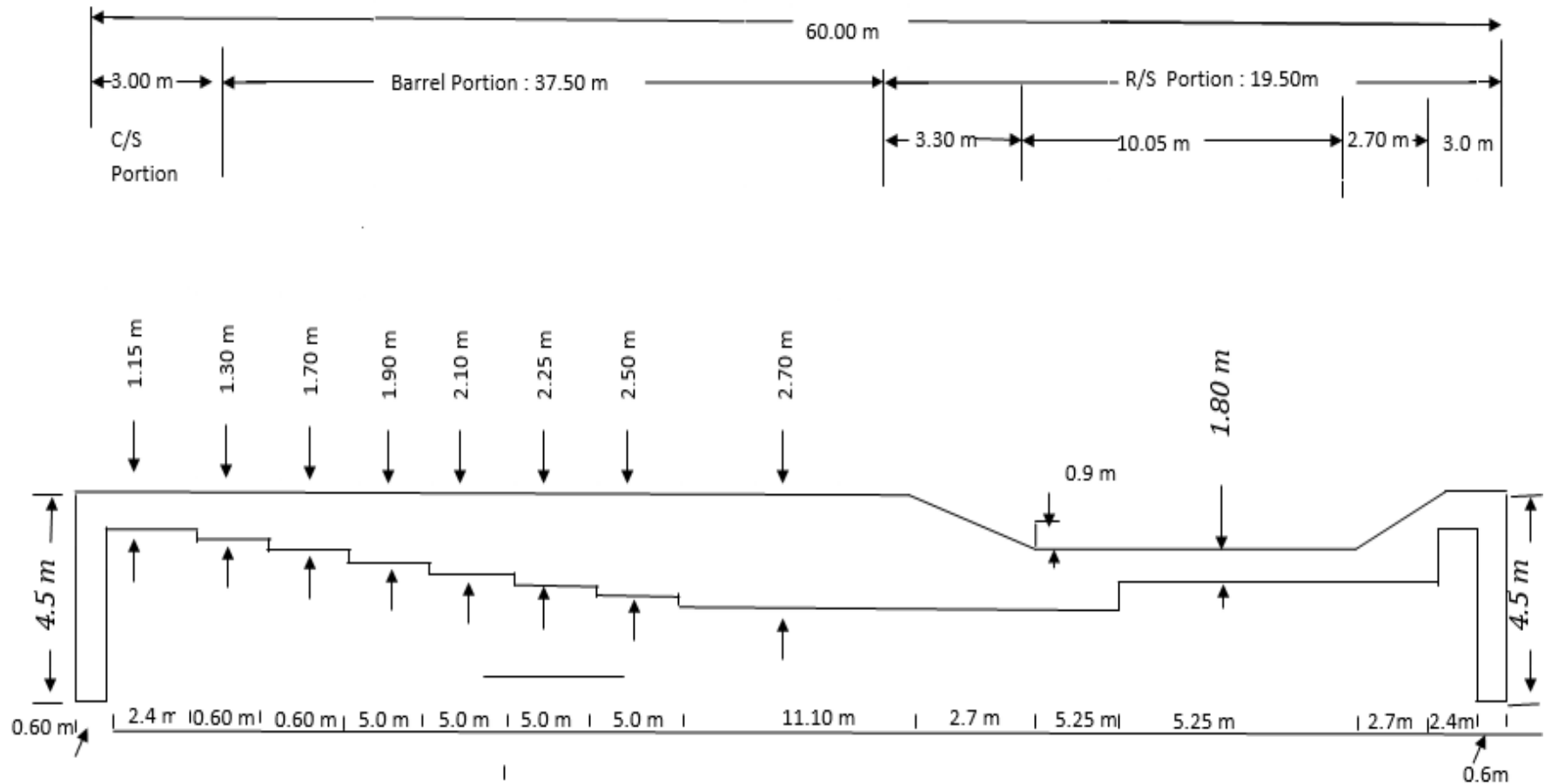

Arrangement of Gravity Floor etc. on the structures

done for

NATIONAL INSTITUTE OF TECHNOLOGY SILCHAR

[A Special Module Prepared by IIT Guwahati as a Part of the Project done by NIT Silchar for Assam State Disaster Management Authority]

REPORT

IMPACT OF CLIMATE CHANGE ON PRECIPITATION OF BARAK BASIN

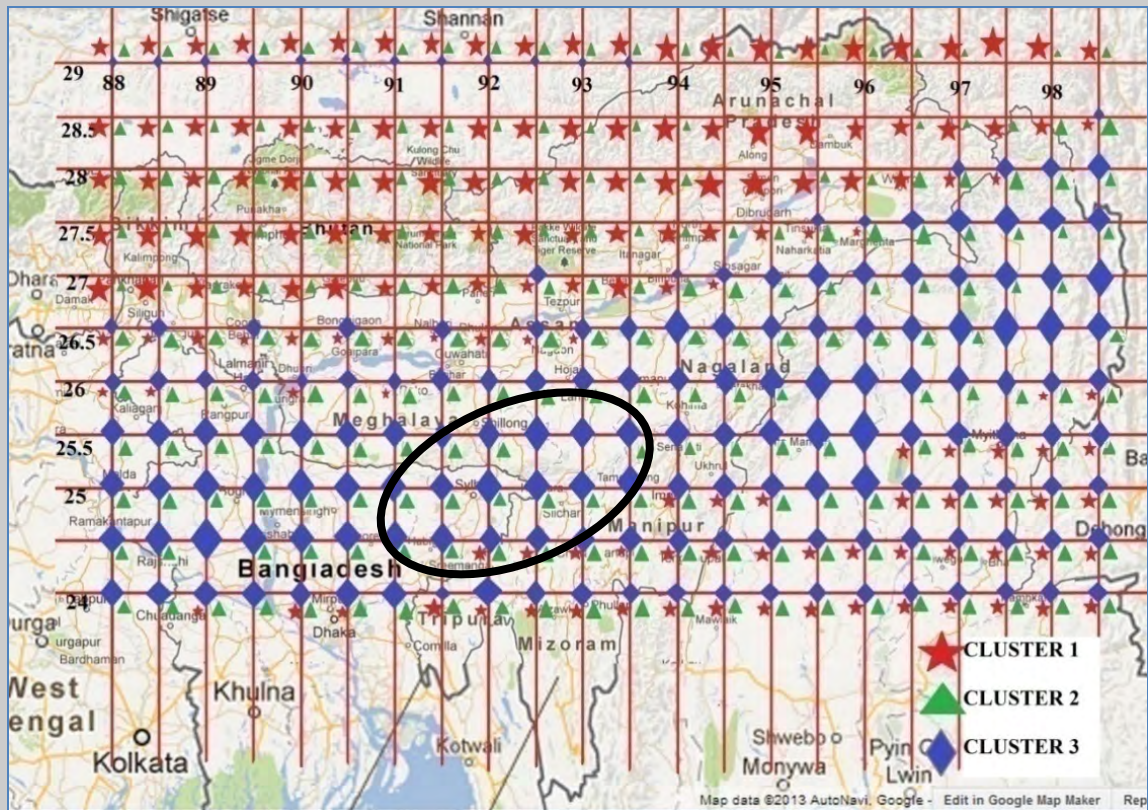

INDIAN INSTITUTE OF TECHNOLOGY
GUWAHATI
North Guwahati, Guwahati – 781 039
ASSAM, INDIA



WORKING GROUP

PRINCIPAL CONSULTANT : PROF. ARUP KUMAR SARMA
PROFESSOR AND HEAD
CIVIL ENGINEERING DEPARTMENT
IIT GUWAHATI
NORTH GUWAHATI
PIN: 781039

E. MAIL: aks@iitg.ernet.in

TEAM MEMBER : Ms. Jayshree Hazarika, M.Tech
PhD Research Scholar
IIT GUWAHATI

IMPACT OF CLIMATE CHANGE ON PRECIPITATION OF BARAK BASIN

ABSTRACT

The North-eastern part of India, which receives heavier rainfall than other parts of the subcontinent, is of great concern now-a-days with regard to climate change. High intensity rainfall for short duration and longer dry spell, occurring due to impact of climate change, affects not only flood and draught situation, but river morphology too. Several studies have been done by IIT Guwahati on future prediction of rainfall at different locations of NE region of India using different GCMs and downscaling techniques. However, most of these studies were done on the impact of climate change on the precipitation and streamflow characteristic of Brahmaputra River or its tributaries. These studies show that results of statistical downscaling to different station-point shows different range of future changes, which indicates importance to determine hydrological homogeneity of the basin before concluding on a best-fit model. As the results of Brahmaputra and its tributary cannot be extended to predict changes in Barak Basin, therefore, a study is conducted first to delineate the north-eastern region of India into some homogeneous clusters. Suitable GCM parameters and data of 10 IMD (Indian Meteorological Department) stations, situated in various regions of the North-east, were used for making the clusters. The results of the Fuzzy C-Means (FCM) analysis show different clustering patterns for different conditions. Two clearly visible clusters can be determined from the study, one in the Brahmaputra valley region and the other in Barak valley region. Studies related to future prediction of rainfall pattern have been done on Silchar station, which is taken as a representative of the Barak basin. Calibration and validation as well as future prediction of rainfall pattern have been done for Silchar. From the analysis, it was seen that maximum monthly precipitation may increase by 16% to 19% in the next 60 years and may again become similar to that of the present situation by 2100. Shifting of peak monthly precipitation has been observed, i.e., there may be delay in peak monsoon. The average increase in total yearly precipitation was however found to be 2.1% from MLR analysis whereas from MLR analysis with residual r , it was found to be 1.97%.

CONTENTS

ABSTRACT	0
LIST OF TABLES	2
LIST OF FIGURES	3
1. INTRODUCTION	4
2. FUZZY CLUSTERING	5
2.1 Methodology	5
2.1.1 Fuzzy C-Means (FCM) Clustering	6
2.1.2 Fuzzy C-Means (FCM) Algorithm to Delineate Homogeneous Precipitation Regions	6
2.1.3 Parameters of the FCM Algorithm	8
2.2 Application	8
4. DOWNSCALING OF SILCHAR STATION SITUATED IN BARAK VALLEY REGION	14
4. CONCLUSION	26
REFERENCES	27

LIST OF TABLES

Table 1. 1 <i>Latitude-longitude-elevation of the IMD stations</i>	8
Table 2. 1 Annual peak and total annual precipitation (from MLR)	23
Table 2. 2 Annual peak and total annual precipitation (from MLR with r)	23
Table 2. 3 Monsoonal peak and total monsoonal precipitation (from MLR)	24
Table 2. 4 Monsoonal peak and total monsoonal precipitation (from MLR with r)	24
Table 2. 5 Average value obtained from all the models	25

LIST OF FIGURES

Figure 2. 1 <i>Clustering done using precipitation data (yearly data used)</i>	10
Figure 2. 2 <i>Clustering done using precipitation data (monsoon data used)</i>	11
Figure 2. 3 <i>Clustering done using GCM data of nearby grid points (yearly data used)</i>	11
Figure 2. 4 <i>Clustering done using GCM data of nearby grid points (monsoon data used)</i>	12
Figure 2. 5 <i>Clustering done using interpolated GCM data (yearly data used)</i>	12
Figure 2. 6 <i>Clustering done using interpolated GCM data (monsoon data used)</i>	12
Figure 2. 7 <i>Clustering done for gridded rainfall data (both yearly data and monsoon data used)</i>	13
Figure 3. 1 <i>Calibration for Silchar station using HadCM3 model</i>	14
Figure 3. 2 <i>Validation for Silchar station using HadCM3 model</i>	15
Figure 3. 3 <i>Calibration for Silchar using HadCM3 model for monsoon season</i>	15
Figure 3. 4 <i>Validation for Silchar using HadCM3 model for monsoon season</i>	16
Figure 3. 5 <i>Calibration for Silchar using 6 LSAVs</i>	16
Figure 3. 6 <i>Validation for Silchar using 6 LSAVs</i>	17
Figure 3. 7 <i>Calibration for Silchar using 4 LSAVs</i>	17
Figure 3. 8 <i>Validation for Silchar using 4 LSAVs</i>	17
Figure 3. 9 <i>Calibration for Silchar using 3 LSAVs (for monsoon)</i>	18
Figure 3. 10 <i>Validation for Silchar using 3 LSAVs (for monsoon)</i>	18
Figure 3. 11 <i>Calibration for Silchar using 1 LSAV (for monsoon)</i>	19
Figure 3. 12 <i>Validation for Silchar using 1 LSAV (for monsoon)</i>	19
Figure 3. 13 <i>Validation curves obtained from MLR (for full years data)</i>	20
Figure 3. 14 <i>Validation curves obtained from MLR with r (for full years data)</i>	20
Figure 3. 15 <i>Validation curves obtained from MLR (for monsoon data)</i>	20
Figure 3. 16 <i>Validation curves obtained from MLR with r (for monsoon data)</i>	21
Figure 3. 17 <i>Precipitation for Silchar station</i>	21
Figure 3. 18 <i>Precipitation for Silchar station</i>	22
Figure 3. 19 <i>Precipitation for Silchar station in monsoon</i>	22
Figure 3. 20 <i>Precipitation for Silchar station in monsoon</i>	23

1. INTRODUCTION

In today's world, one of the most important issues related to various water resources planning is the impact of climate change on future water scenario. To have a fair idea on impact of climate change in a vast country like India, where climate conditions differ from place to place, is of major concern, because country's economic performance and social progress are dependent on rainfall. The north-eastern part of India receives heavier rainfall than other parts of the subcontinent. High intensity rainfall for short duration and longer dry spell are the major problems due to impact of climate change. Therefore planning and management of water resources related issues in the north-eastern part of India should definitely include the impacts of climate change.

Several studies have already been done on impact of climate change on water resources of various parts of the North-eastern region of India (Deka and Sarma 2010, Vinnarasi and Sarma 2011, Sarma and Kalita, 2012). Most of these studies were on the impact of climate change on the precipitation and streamflow characteristic of Brahmaputra River or its tributaries. To study the impacts of climate change on rainfall, future predictions of the rainfall patterns was done with the use of downscaling techniques. Three Global Climate Models (GCM), namely CGCM3, HadCM3, and MRCGCM2, were downscaled using statistical downscaling technique for predicting monthly weather data under A2 scenario. Depending on the location of interest downscaling was done to different points and interestingly the range of changes estimated at different points of the same river basin was found to vary significantly, though the trend of change was matching. The downscaling results, then, was used to predict the future rainfall intensity, number of dry days etc. These studies indicated that, in future, the maximum monthly precipitation may increase by as high as 20% and the rainfall intensity may increases by 14%. Such change in precipitation pattern is of major concern, as this may lead to several problems in the field of water and agricultural management. Severe flood during monsoon month and severe drought in lean period, morphological change in river causing bank erosion, reduction in ground water table etc. are some of the hydrological problems that are expected to increase because of climate change impact. To study the impacts of climate change on stream flow behaviour, two methods were used. The first one is rainfall-runoff modelling with an input of downscaled precipitation using Watershed Modelling System (WMS) Software. The second method is by direct downscaling of streamflow from HadCM3 model under A2 scenario using Artificial Neural Network (ANN) model. Direct downscaling of streamflow was found to be encouraging compared to rainfall-runoff modelling in climate change predictions because of paucity of landuse and other related data. From the results, it was found that maximum monthly streamflow is shifting towards late monsoon period. Result of these studies indicated that impact of climate change in the NE region is significant and its effect differs from point to pint. Therefore, to have clear idea about impact of Climate Change in Barak basin a detail study with delineation of hydrological homogeneous region is necessary.

This report contains a study of hydrological homogeneous region in the NE region of India and future precipitation prediction in the Barak basin due to impact of climate change.

2. FUZZY CLUSTERING AND ANALYSIS OF BARAK BASIN

Previous studies show that results of statistical downscaling to different station-point shows different range of future changes. Also, different GCMs perform differently in different station points. Hence, selection of appropriate model as well as downscaling technique is not very clear from any of those works. Therefore, it is important to determine hydrological homogeneity of the basin before concluding on a best-fit model. Moreover, because of the same reason, the result of Brahmaputra and its tributary cannot be extended to predict changes in Barak Basin even though Barak River is located in the same region and in fact can be considered as a tributary of Brahmaputra, which meets the river Brahmaputra beyond the territory of India, where Brahmaputra takes a different name. In addition, the hydrological setup of Barak Basin is different from that of the Brahmaputra basin, as low altitude hills without having snow cover surround this basin. Therefore, a study is conducted first to delineate the north-eastern region of India into some homogeneous clusters. The basic objective of clustering is to determine appropriate GCM and downscaling technique for a homogeneous region for water resources planning and management. The clustering analysis has been done based on the Fuzzy Clustering concept and the resulting clusters obtained by using conventional methods and non-conventional methods are being compared.

2.1 Methodology

Fuzzy clustering is the clustering technique which allows the objects to belong to several clusters simultaneously, with different degrees of membership. In many situations, fuzzy clustering is more natural than hard clustering, where an object is bound to belong to a single cluster. Objects on the boundaries between several classes are not forced to fully belong to one of the classes, but rather are assigned membership degrees between 0 and 1 indicating their partial membership.

Generalization of the hard partition to the fuzzy case follows directly by allowing μ_{ik} to attain real values in $[0, 1]$. Conditions for a fuzzy partition matrix are given by:

$$\mu_{ik} \in [0, 1], 1 \leq i \leq c, 1 \leq k \leq N,$$

$$\sum_{i=1}^c \mu_{ik} = 1, 1 \leq k \leq N,$$

$$0 < \sum_{k=1}^N \mu_{ik} < N, 1 \leq i \leq c.$$

The i^{th} row of the fuzzy partition matrix \mathbf{U} contains values of the i^{th} membership function of the fuzzy subset A_i of \mathbf{Z} . Second equation constrains the sum of each column to 1, and thus the total membership of each \mathbf{z}_k in \mathbf{Z} equals one.

2.1.1 Fuzzy C-Means (FCM) Clustering

Most analytical fuzzy clustering algorithms are based on optimization of the basic c-means objective function, or some modification of it. **The Fuzzy c-Means Functional**, which is to be minimised, is formulated as:

$$J(\mathbf{Z}; \mathbf{U}, \mathbf{V}) = \sum_{i=1}^c \sum_{k=1}^N (\mu_{ik})^m \|z_k - v_i\|^2 A$$

Where, $\mathbf{U} = [\mu_{ik}] \in M_{fc}$ is a fuzzy partition matrix of \mathbf{Z} .

$\mathbf{V} = [v_1, v_2, \dots, v_c]$, $v_i \in \mathbb{R}^n$ is a vector of cluster prototypes (centers), which have to be determined.

$d^2(z_k, v_i)A = D_{ikA}^2 = \|z_k - v_i\|^2 A = (z_k - v_i)^T A (z_k - v_i)$ is a squared inner-product distance norm, and

$m = [1, \infty)$ is a parameter which determines the fuzziness of the resulting clusters.

2.1.2 Fuzzy C-Means (FCM) Algorithm to Delineate Homogeneous Precipitation Regions

Suppose there are N sites in a study area. The ' n ' attributes, influencing precipitation at each site, have to be identified. The attributes may include large scale atmospheric variables (LSAVs) or their principal components, location parameters (latitude, longitude and altitude), and seasonality measures. Subsequently, a feature vector is formed for each site using the identified attributes for the site.

The i^{th} site is denoted in n -dimensional attribute space by the feature vector

$$\mathbf{y}_i = [y_{i1}, \dots, y_{ji}, \dots, y_{ni}]^T \in \mathbb{R}^n,$$

Where, y_{ji} is the value of j^{th} attribute in \mathbf{y}_i . The attributes of \mathbf{y}_i are rescaled using:

$$x_{ji} = \frac{(y_{ji} - \bar{y}_j)}{\sigma_j}, \text{ for } 1 \leq j \leq n, 1 \leq i \leq N$$

Where, x_{ji} denotes the rescaled value of y_{ji} ,

σ_j represents the standard deviation of attribute j , and

\bar{y}_j is the mean value of attribute j over all the N feature vectors.

Rescaling the attributes is necessary to nullify the differences in their variance, relative magnitude and importance. Otherwise, attributes having greater magnitude and variance influence the formation of clusters, which is undesirable. If certain attributes are known to be more important than others in influencing precipitation in the study area, the rescaling should be such that the variances of rescaled values of those attributes are greater than those of the less important attributes.

Let $\mathbf{X} = (\mathbf{x}_1, \dots, \mathbf{x}_i, \dots, \mathbf{x}_N)$ denote matrix containing rescaled feature vectors, where \mathbf{x}_i is rescaled feature vector for the i^{th} site. Next task is to partition \mathbf{X} into c soft clusters using Fuzzy c -means (FCM) algorithm, to arrive at optimum value of the following objective function:

$$\text{Minimize, } J(\mathbf{X}; \mathbf{U}, \mathbf{V}) = \sum_{k=1}^c \sum_{i=1}^N (\mu_{ki})^m \|\mathbf{x}_i - \mathbf{v}_k\|^2$$

or can be written as,

$$\text{Minimize, } J(\mathbf{X}; \mathbf{U}, \mathbf{V}) = \sum_{k=1}^c \sum_{i=1}^N (\mu_{ki})^m d^2(\mathbf{x}_i, \mathbf{v}_k)$$

Subject to the following constraints,

$$\sum_{k=1}^c \mu_{ki} = 1 \quad \forall i \in \{1, \dots, N\}$$

$$0 < \sum_{i=1}^N \mu_{ki} < N \quad \forall k \in \{1, \dots, c\}$$

Where $\mathbf{V} = (\mathbf{v}_1, \dots, \mathbf{v}_k, \dots, \mathbf{v}_c)$ represents a matrix containing cluster centroids. $\mathbf{v}_k = [v_{1k}, \dots, v_{jk}, \dots, v_{nk}] \in \mathbb{R}^n$ denotes centroid of k^{th} soft cluster,

$\mu_{ki} \in [0, 1]$ denotes the membership of x_i in the k^{th} soft cluster;

\mathbf{U} is the fuzzy partition matrix which contains the membership of each rescaled feature vector in each soft cluster;

the parameter $m \in [1, \infty)$ refers to the weight exponent for each fuzzy membership, and is known as fuzzifier;

$d(\mathbf{x}_i, \mathbf{v}_k)$ is the distance from \mathbf{x}_i to \mathbf{v}_k .

The iterative procedure of **FCM algorithm** used to arrive at homogeneous precipitation regions is summarized below:

- i. Initialize fuzzy partition matrix \mathbf{U} using a random number generator.
- ii. Adjust the initial memberships μ_{ki}^{init} of x_i belonging to cluster k using the following equation:

$$\mu_{ki} = \frac{\mu_{ki}^{\text{init}}}{\sum_{j=1}^c \mu_{ji}^{\text{init}}}, \quad \text{for } 1 \leq k \leq c, 1 \leq i \leq N$$

- iii. Compute the fuzzy cluster centroid \mathbf{v}_k as

$$\mathbf{v}_k = \frac{\sum_{i=1}^N (\mu_{ki})^m \mathbf{x}_i}{\sum_{i=1}^N (\mu_{ki})^m}, \quad \text{for } 1 \leq k \leq c$$

- iv. Update the fuzzy membership μ_{ki} as

$$\mu_{ki} = \frac{\left(\frac{1}{d^2(\mathbf{x}_i, \mathbf{v}_k)}\right)^{\frac{2}{m-1}}}{\sum_{k=1}^c \left(\frac{1}{d^2(\mathbf{x}_i, \mathbf{v}_k)}\right)^{\frac{2}{m-1}}}, \quad \text{for } 1 \leq k \leq c, 1 \leq i \leq N$$

- v. Compute the value of objective function as

$$J(\mathbf{X}; \mathbf{U}, \mathbf{V}) = \sum_{k=1}^c \sum_{i=1}^N (\mu_{ki})^m d^2(\mathbf{x}_i, \mathbf{v}_k)$$

Repeat the steps (iii) to (v) until change in the value of objective function between two successive iterations becomes sufficiently small.

2.1.3 Parameters of the FCM Algorithm

Before using the FCM algorithm, the following parameters must be specified:

- the number of clusters, c ,
- the ‘fuzziness’ exponent or fuzzifier, m ,
- the termination tolerance (absolute difference between two successive iterations), and
- The fuzzy partition matrix, U .

The choices for these parameters are now described one by one.

• **Number of clusters:-** The number of clusters c is the most important parameter, in the sense that the remaining parameters have less influence on the resulting partition. When clustering real data without any a priori information about the structures in the data, one usually has to make assumptions about the number of underlying clusters. The chosen clustering algorithm then searches for c clusters, regardless of whether they are really present in the data or not.

• **Fuzziness Parameter:-** The weighting exponent m is an important parameter because it significantly influences the fuzziness of the resulting partition. As m approaches 1 ($m \rightarrow 1$), the partition becomes hard ($\mu_{ik} \in \{0, 1\}$). As $m \rightarrow \infty$, the partition becomes completely fuzzy ($\mu_{ik} = 1/c$). Usually, $m = 2$ is initially chosen.

• **Termination tolerance:-** The FCM algorithm stops iterating when the norm of the difference between U in two successive iterations is smaller than the termination tolerance. Usually 0.001 is taken, even though 0.01 works well in most cases, while drastically reducing the computing times.

• **Fuzzy partition matrix, U :-** The fuzzy partition matrix must be initialized at the beginning. However, taking random value for U is also acceptable as the algorithm is not affected by the initial value of U .

2.2 Application

In this study, for making the clusters, 10 IMD (Indian Meteorological Department) stations, situated in various regions of the North-east, have been selected (Table 1.1). On the Basis of IMD data available for those stations, homogeneous clustering has been done.

Table 1. 1 *Latitude-longitude-elevation of the IMD stations*

Index No.	Name of the stations	Region	Latitude	Longitude	Elevation
42220	Passighat (VEPG)	Arunachal	28° 6' 0" N (28.1°)	95° 23' 0" E (95.3833°)	157 m (515 ft)
42309	North-lakhimpur (VELR)	Assam	27° 14' 0" N (27.2333°)	94° 7' 0" E (94.1167°)	101 m (331 ft)
42314	Mohanbari (VEMN)	Assam	27° 29' 2" N	95° 1' 1" E	111 m

			(27.4839°)	(95.0169°)	(364 ft)
42404	Dhubri	Assam	26°1'0" N (26.0167°)	89°59'0" E (89.9833°)	35 m (115 ft)
42410	Guwahati (VEGT)	Assam	26°6'22" N (26.1061°)	91°35'9" E (91.5859°)	54 m (177 ft)
42415	Tezpur	Assam	26°37'0" N (26.6167°)	92°47'0" E (92.7833°)	91 m (299 ft)
42515	Cherrapunjee	Meghalaya	25°15'0" N (25.25°)	91°44'0" E (91.7333°)	1300 m (4265 ft)
42516	Shillong	Meghalaya	25°34'0" N (25.5667°)	91°53'0" E (91.8833°)	1600 m (5249 ft)
42619	Silchar	Assam	24°45'0" N (24.75°)	92°48'0" E (92.8°)	21 m (70 ft)
42623	Imphal (VEIM)	Manipur	24°45'36" N (24.7599°)	93°53'48" E (93.8967°)	774 m (2539 ft)

Three types of data have been used in this study, namely

1. Observed precipitation data of each station, collected from IMD
2. GCM (Global Climate models) data collected from IPCC
3. Daily gridded rainfall data of size 0.5×0.5 , collected from IMD, Pune.

1. Observed precipitation data

Observed daily precipitation data have been collected from Indian Meteorological Department (IMD) under an MOU between IIT Guwahati and IMD. The time period of data collection is from 01-01-1969 to 31-01-2012. However, no data are available for any station from 2001 to 2005.

2. GCM data

The GCM data are downloaded from Intergovernmental Panel on Climate Change (IPCC) from Fourth Assessment Report (AR4). The time period of fourth assessment is from 2001 to 2100. In this study, GCM model, HadCM3, with A2 simulation run has been used. A2 scenario considers a very heterogeneous world with continuously increasing global population and regionally oriented economic growth. It considers the forcing effect of greenhouse gases and sulphate aerosol direct effect, which are based on IPCC SRES-A2 (Special Report on Emission Scenario A2).

3. Daily gridded rainfall data

Daily gridded rainfall data are collected from Indian Meteorological department, Pune. The time period of data collection is from 01-01-1971 to 31-12-2005. The data are available for whole Indian sub-continent with resolution as high as 0.5×0.5 . Data of the North-eastern part, that is required for the analysis, are separated out from the whole data.

The clustering has been done for the following cases:

- Regionalization using GCM data of nearby grid points (both for annual data and monsoon data)

- Regionalization using observed precipitation data (both for annual data and monsoon data)
- Regionalization using interpolated GCM data (both for annual data and monsoon data)
- Regionalization using gridded rainfall data (both for annual data and monsoon data)

In cases where GCM data had been used, the first work is to find out the LSAVs, which influence the precipitation of a particular station. For doing this, a relation has to be established between the observed precipitation data and the LSAVs. In the present work, Pearson Correlation is considered to be an effective way to find out the relation. Hence, for each station, Pearson coefficients were calculated using the data available. It has been observed from the correlation results (not shown for brevity) that precipitation data of different stations have different correlation with different LSAVs. Hence those LSAVs, which have good relations with precipitation data of most of the stations, are selected as attributes.

To reduce the curse of high dimensionality, mean monthly values of each of the LSAVs were computed at each of the 10 stations. The mean monthly value of a variable denotes the average value of the variable computed for the month, overall years of the historical record. Thus, there are 12 mean monthly values for each LSAV at each IMD station. Since several of the atmospheric variables are correlated to each other, hence to avoid redundancy, Principal Component Analysis (PCA) has been done. In the present work, PCA has been done with the help of MATLAB program.

To proceed with the FCM algorithm, partition matrix U has to be initialized at first. The initial partition matrix U_{init} was determined with the help of geographical location of the stations and cross-correlation among the stations. Taking U_{init} and the data matrix as input the final partition has been calculated with the help of a MATLAB program made for the FCM algorithm.

From the results of the FCM analysis it came into notice that, different clustering has been found for different conditions. Different clustering patterns found from the FCM analyses are shown in the figures below:

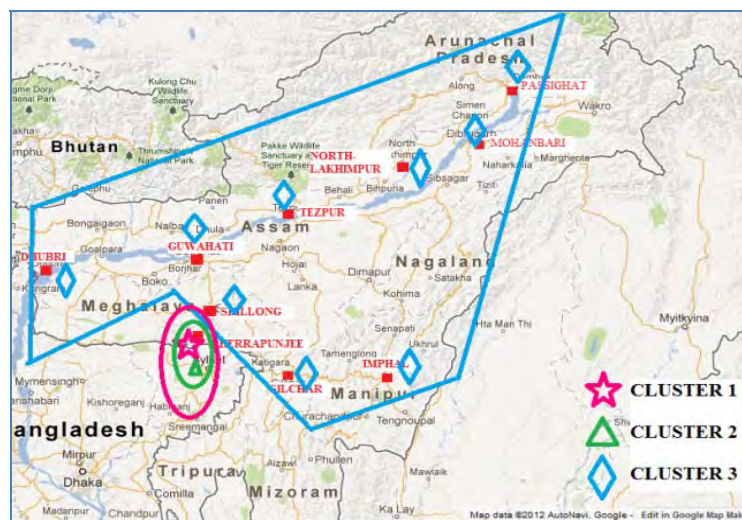

Figure 2.1 Clustering done using precipitation data (yearly data used)

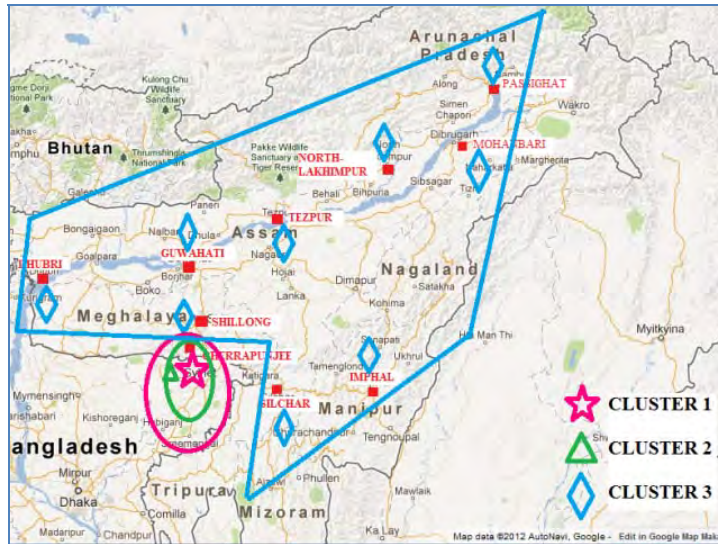

Figure 2. 2 *Clustering done using precipitation data (monsoon data used)*

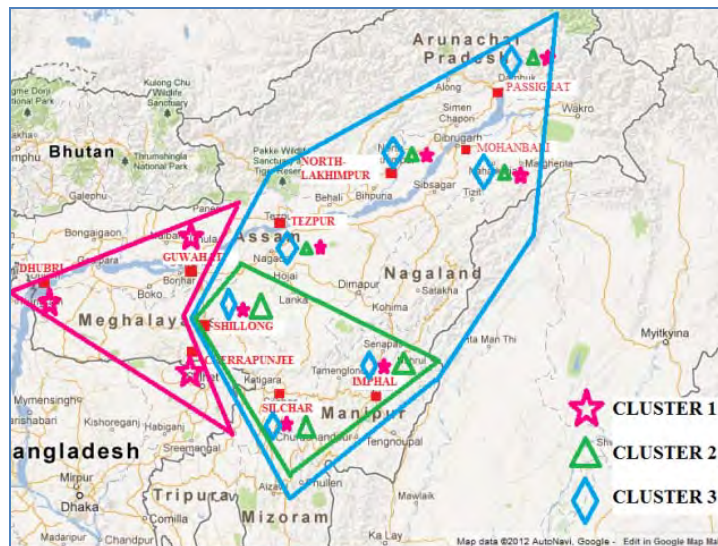

Figure 2. 3 *Clustering done using GCM data of nearby grid points (yearly data used)*

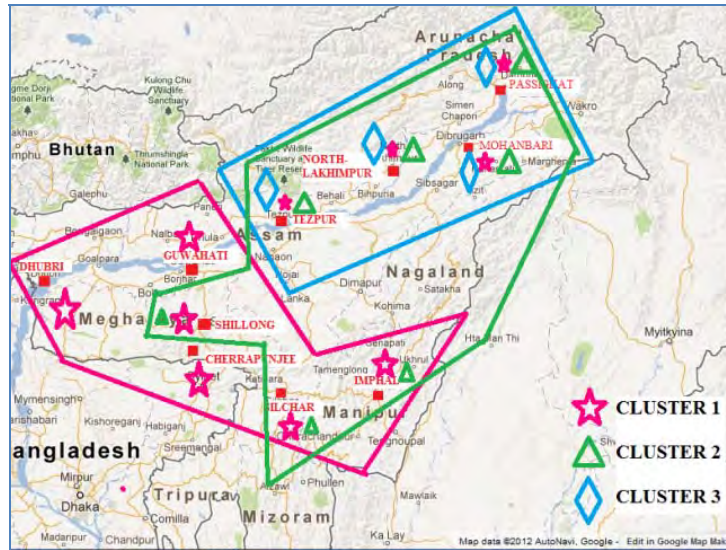

Figure 2.4 Clustering done using GCM data of nearby grid points (monsoon data used)

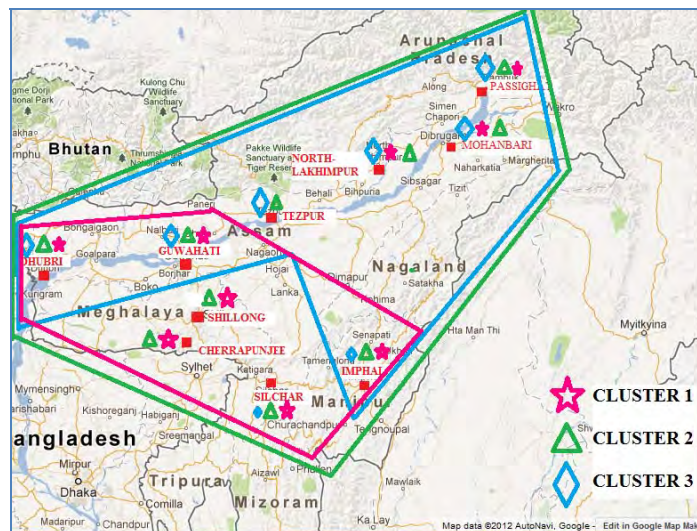

Figure 2.5 Clustering done using interpolated GCM data (yearly data used)

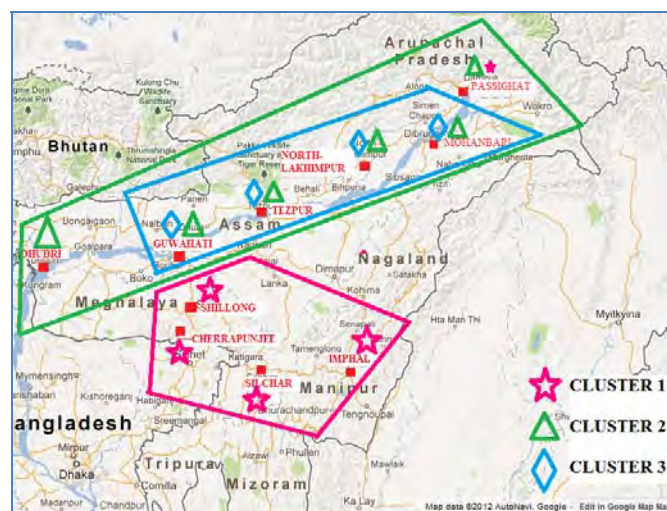

Figure 2.6 Clustering done using interpolated GCM data (monsoon data used)

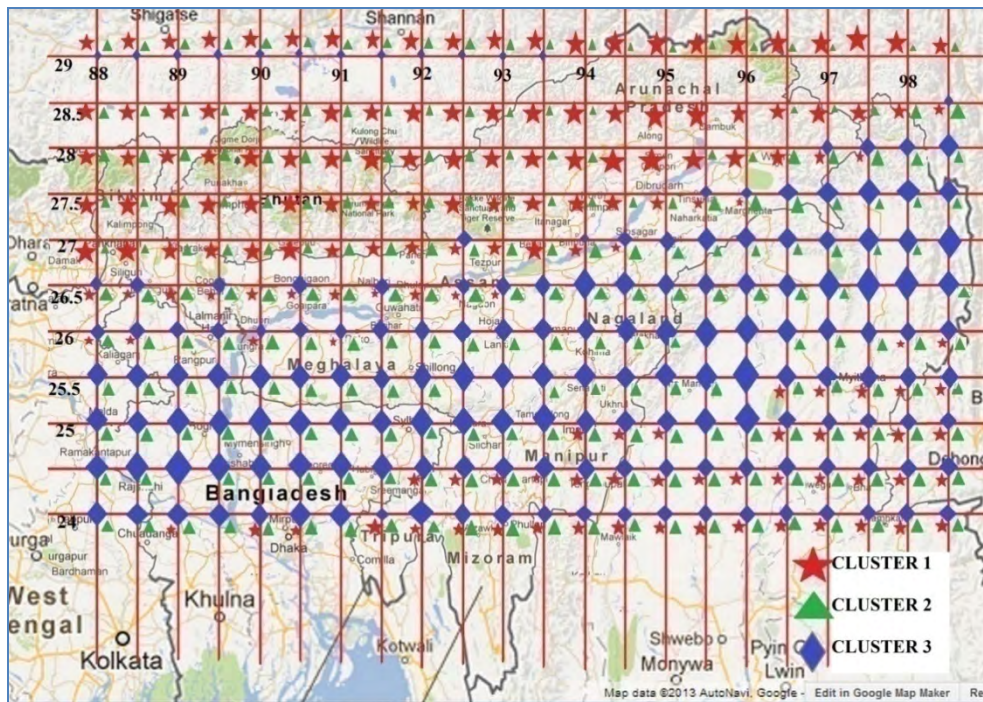

Figure 2.7 *Clustering done for gridded rainfall data (both yearly data and monsoon data used)*

From the results of the FCM it is being noticed that Passighat, North-Lakhimpur, Mohanbari and Tezpur are always coming under the same cluster, which are situated in the Brahmaputra valley region. Hence it can be concluded that these four stations will always come under the same cluster. Similarly, Shillong, Silchar, Imphal and Cherrapunjee are also coming under the same cluster for most of the analyses. These four stations are situated in the Barak valley region. Guwahati is showing equal membership in both the clusters. Dhubri, is showing different results; hence clear statement cannot be given. Therefore, two clearly visible clusters can be determined from the study, one in the Brahmaputra valley region and the other in Barak valley region.

4. DOWNSCALING OF SILCHAR STATION SITUATED IN BARAK VALLEY REGION

As discussed in the previous part of this report, studies related to impacts of climate change on rainfall and stream flow pattern are being done on the Dhansiri river basin, which falls under the Brahmaputra valley region. The future scenario found for the basin represents a considerable part of the Brahmaputra basin. Presently studies are ongoing on prediction of future rainfall pattern of the Barak Valley region. Four stations have been selected viz. Shillong, Silchar, Imphal and Cherrapunjee for the analysis, which are found to be situated in or near the Barak Valley region and are coming under the same cluster from the FCM analyses. Calibration and validation of the GCM data (HadCM3 with A2 scenario) with relation to precipitation data is over. The future prediction part is ongoing for the stations.

Calibration and validation as well as future prediction of rainfall pattern have been done for Silchar. Calibration and validation have been done for different combination of GCM parameters (LSAV data) to find out the best combination of parameters. Furthermore, future data for the long run for some of the GCM parameters (e.g. for zg200, ua500 etc.) are not available with the IPCC site. Hence depending upon the availability of GCM data, some more calibrations and validations have been done for use in such cases. Seven LSAVs have been selected for Silchar station when the analysis had been done for full year viz. hur200, hur500, ta200, ta500, ua200, ua500 and zg200. When the analysis had been done for monsoon only, four LSAVs have been selected viz. ta500, ua200, ua500 and zg200. Figures are shown below:

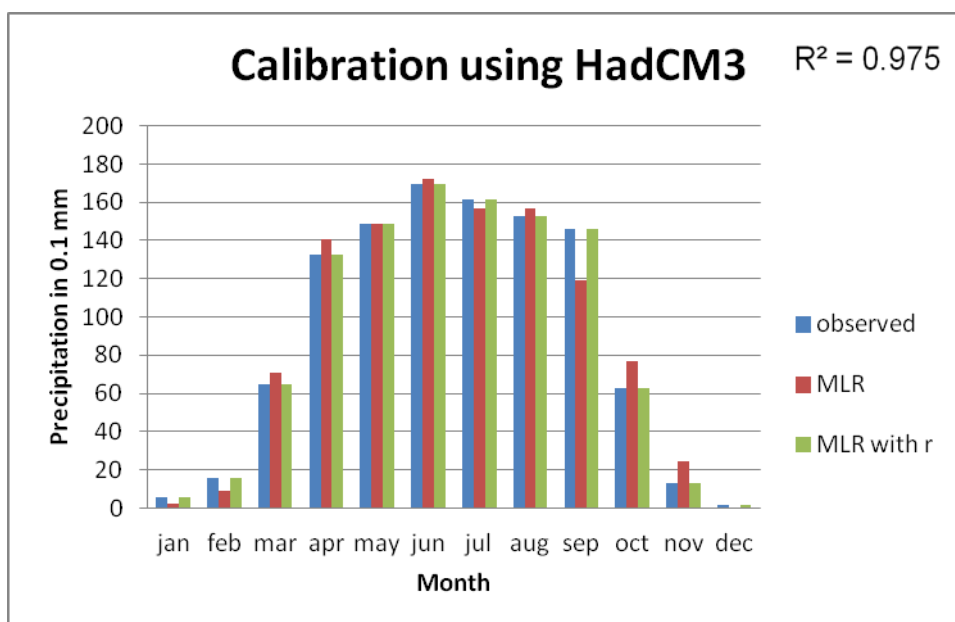

Figure 3.1 Calibration for Silchar station using HadCM3 model

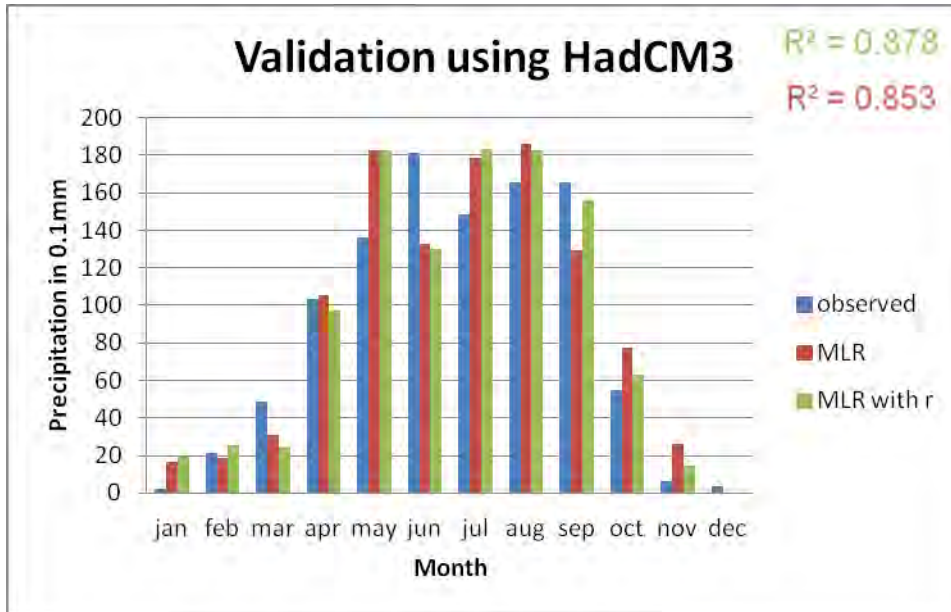

Figure 3.2 Validation for Silchar station using HadCM3 model

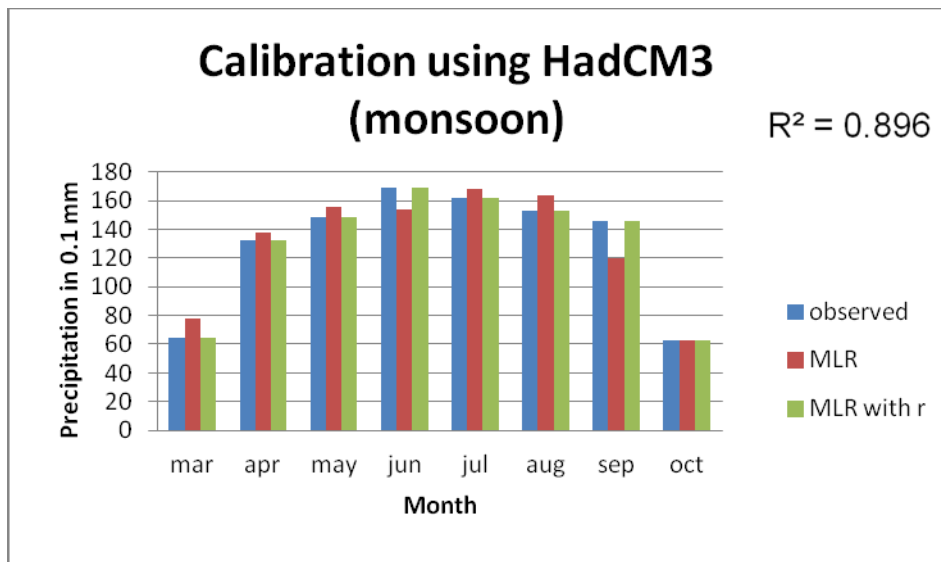

Figure 3.3 Calibration for Silchar using HadCM3 model for monsoon season

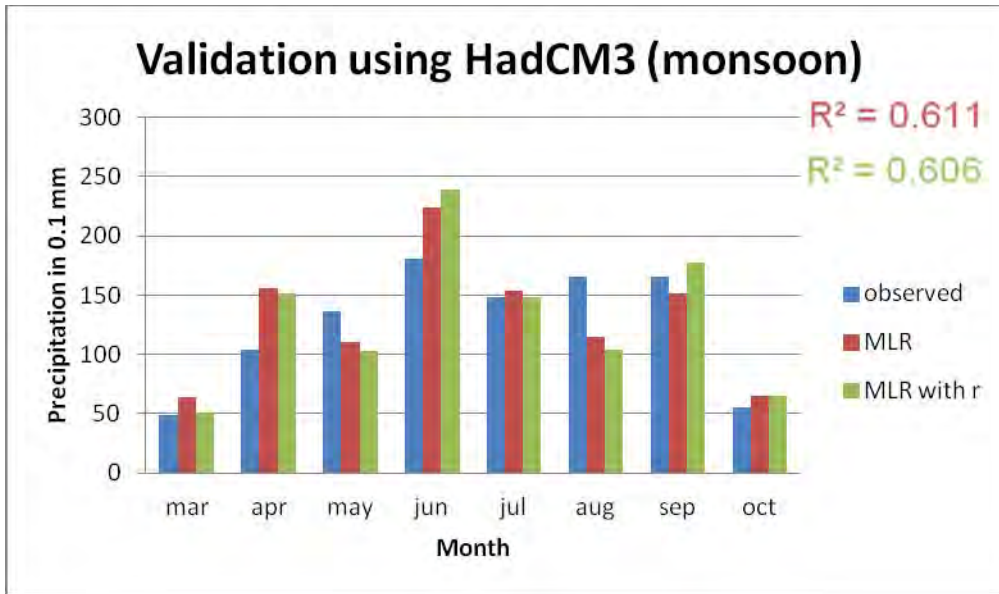

Figure 3.4 Validation for Sihar using HadCM3 model for monsoon season

Calibration and validation done for other combinations of GCM data (LSAVs) are shown in the figures below:

- Analysis done for full years data:
 1. Calibration-validation done using 6 LSAVs (hur200, hur500, ta200, ta500, ua200 and ua500)

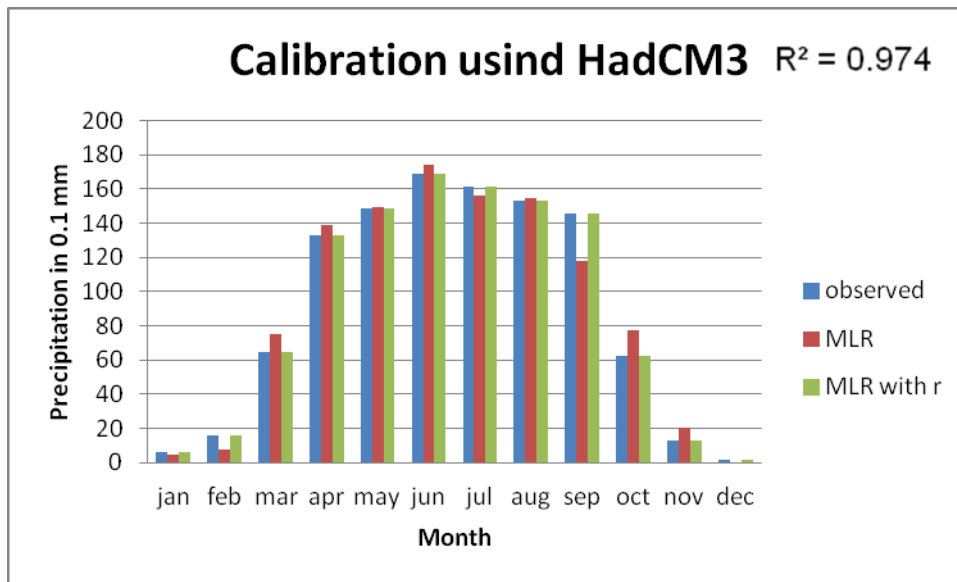

Figure 3.5 Calibration for Silchar using 6 LSAVs

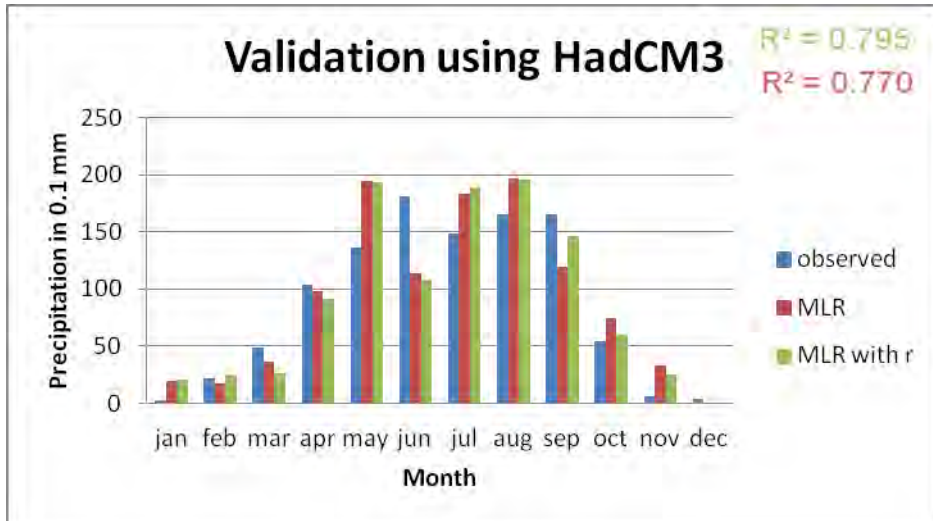

Figure 3.6 *Validation for Silchar using 6 LSAVs*

2. Calibration-validation done using 4 LSAVs (hur200, hur500, ta200 and ta500)

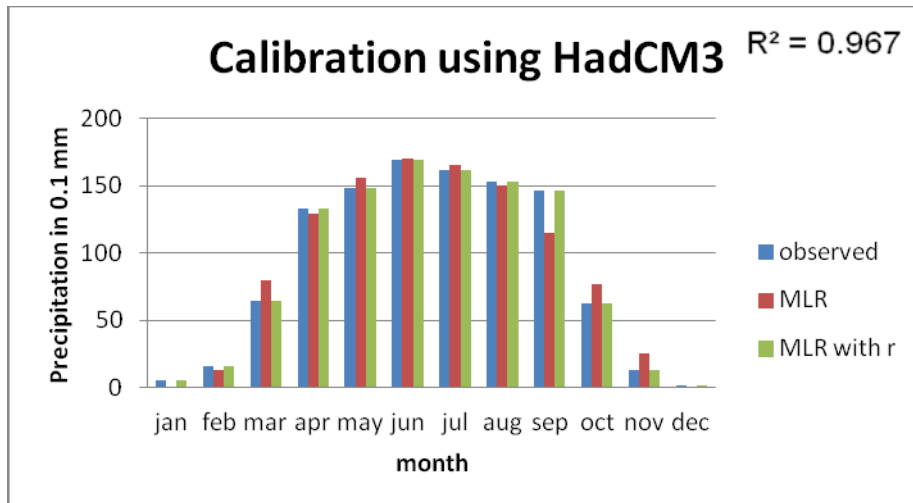

Figure 3.7 *Calibration for Silchar using 4 LSAVs*

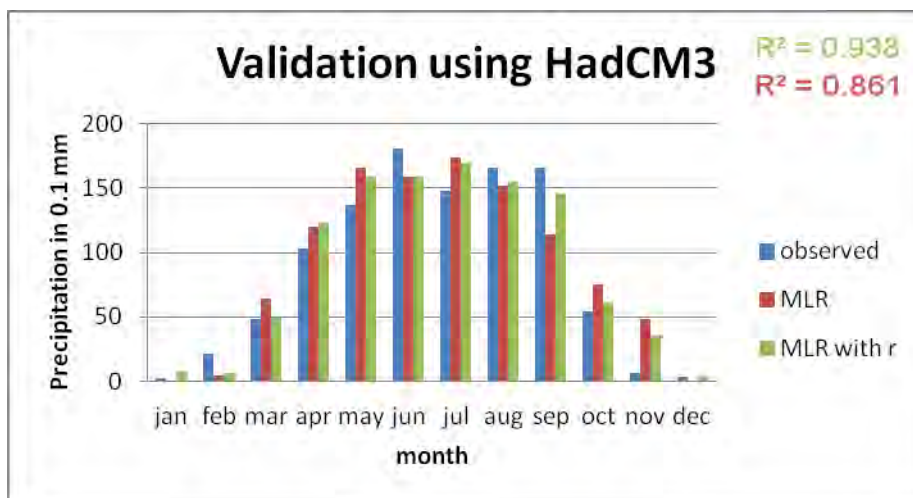

Figure 3.8 *Validation for Silchar using 4 LSAVs*

- Analysis done for monsoon data:
 1. Calibration-validation done using 3 LSAVs (ta500, ua200 and ua500)

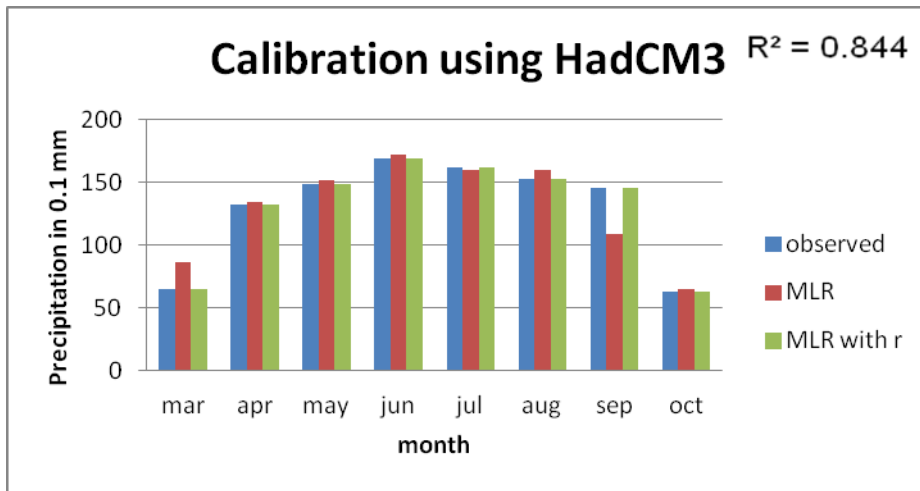

Figure 3.9 *Calibration for Silchar using 3 LSAVs (for monsoon)*

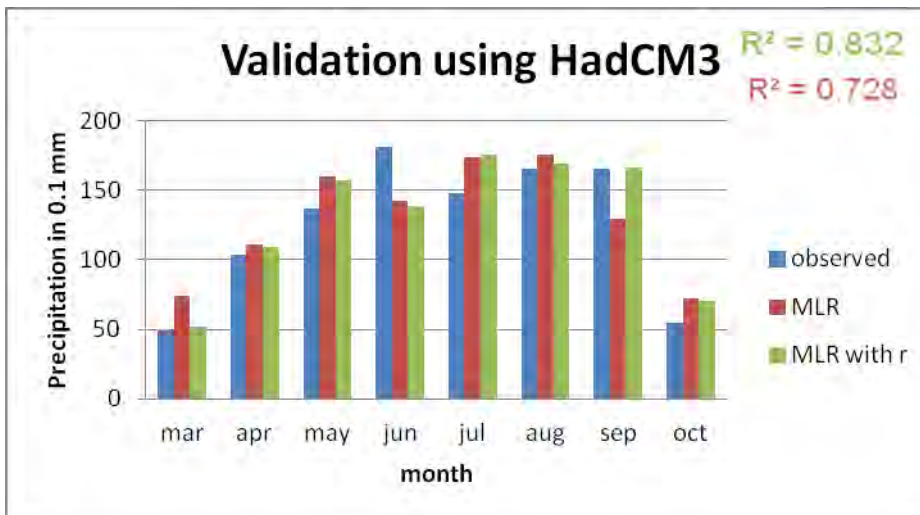

Figure 3.10 *Validation for Silchar using 3 LSAVs (for monsoon)*

2. Calibration-validation done using 1 LSAVs (ta500)

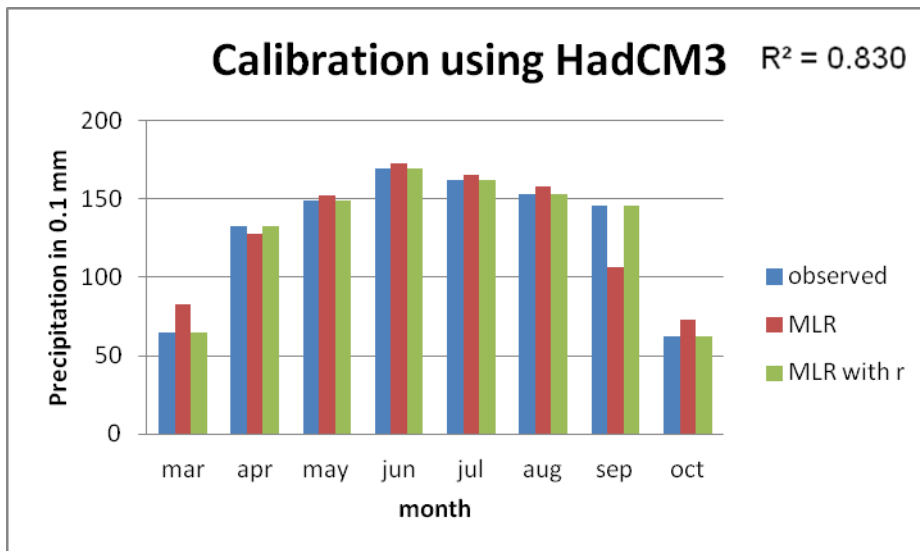

Figure 3. 11 Calibration for Silchar using 1 LSAV (for monsoon)

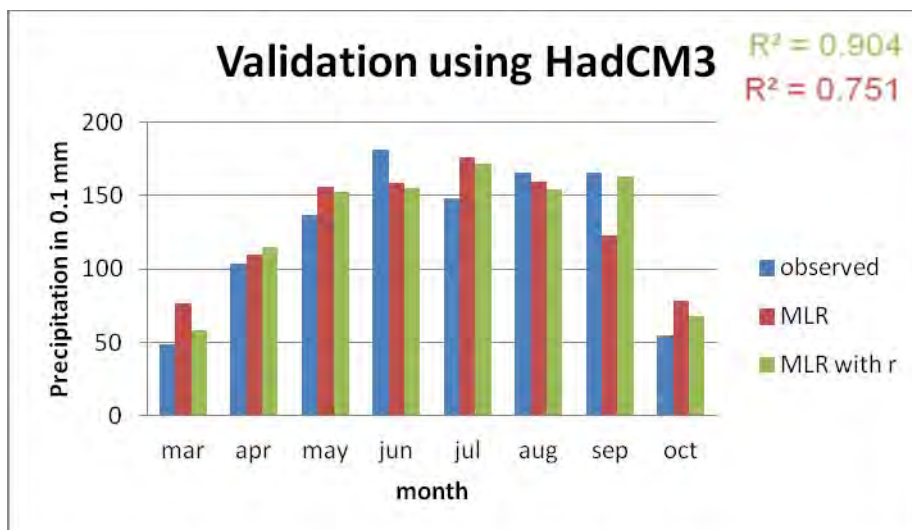

Figure 3. 12 Validation for Silchar using 1 LSAV (for monsoon)

Validation curves are shown below in one figure for better understanding.

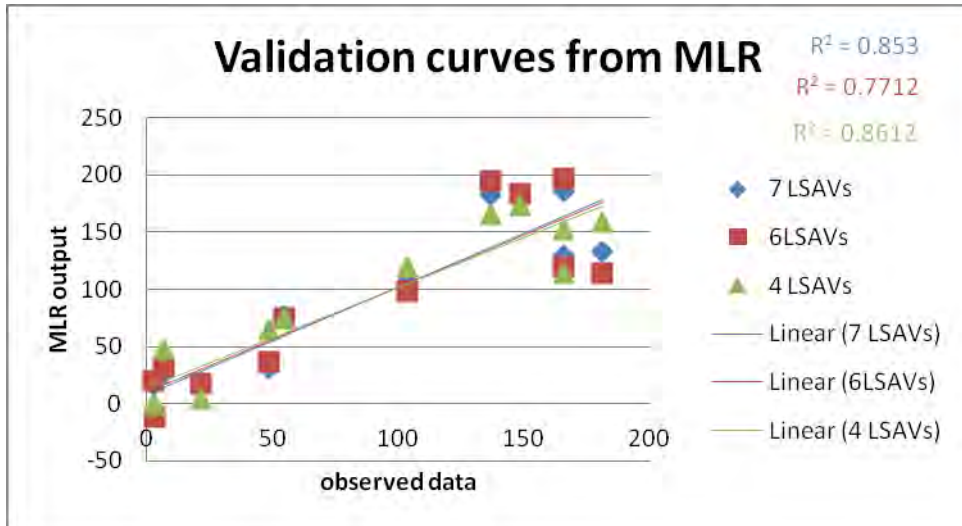

Figure 3. 13 *Validation curves obtained from MLR (for full years data)*

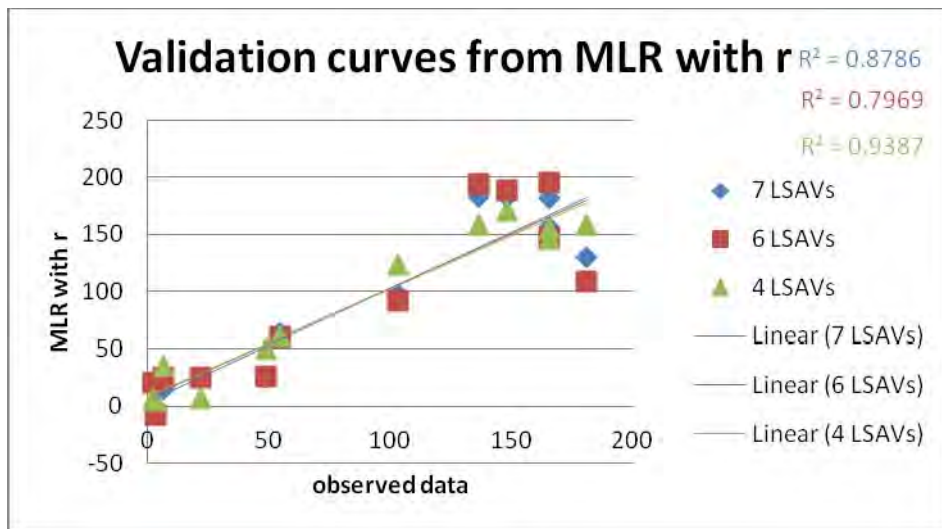

Figure 3. 14 *Validation curves obtained from MLR with r (for full years data)*

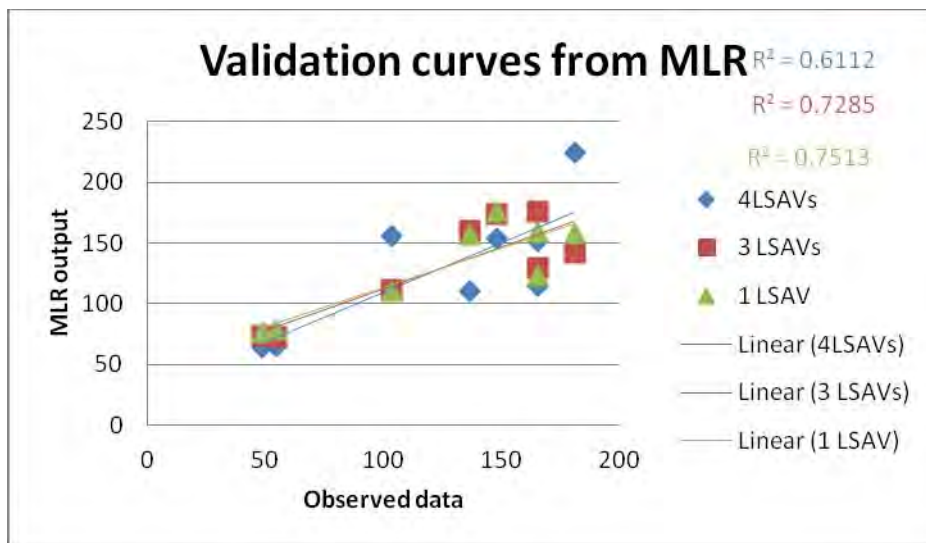

Figure 3. 15 *Validation curves obtained from MLR (for monsoon data)*

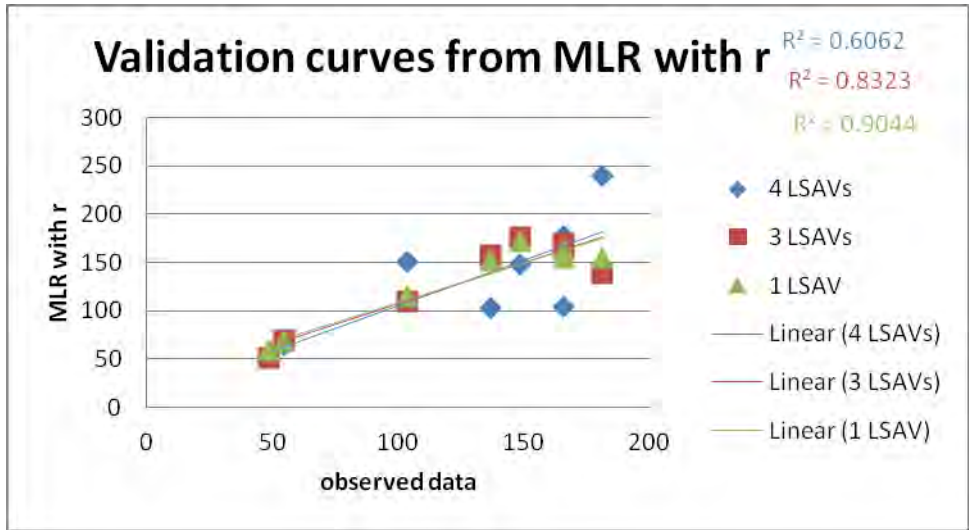

Figure 3. 16 *Validation curves obtained from MLR with r (for monsoon data)*

Based on the calibration-validation results future forecasting has been done for Silchar station. Total time period is divided into three time series i.e. 2012-2040, 2041-2070 and 2071-2099. Depending upon availability of LSAV data, suitable models, developed from calibration-validation, have been used for future forecasting. The output data are plotted in the graphs below:

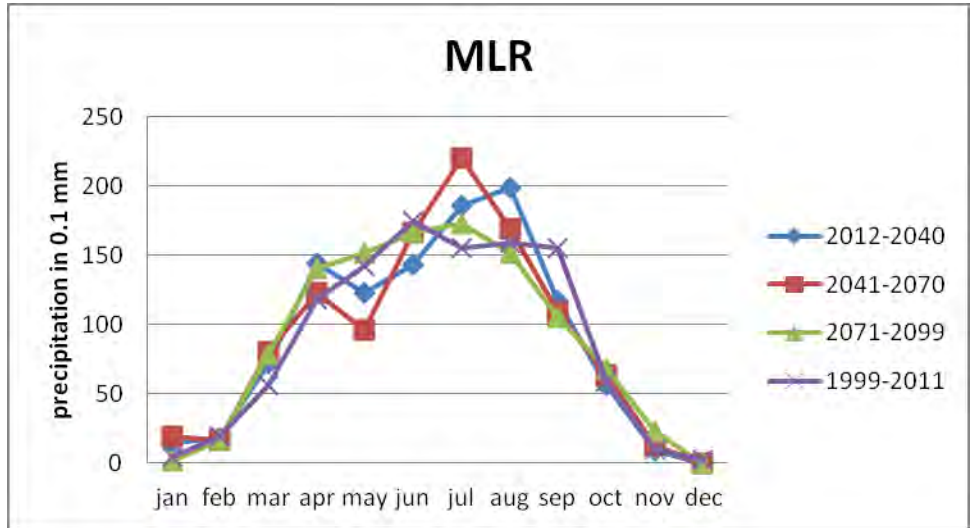

Figure 3. 17 *Precipitation for Silchar station*

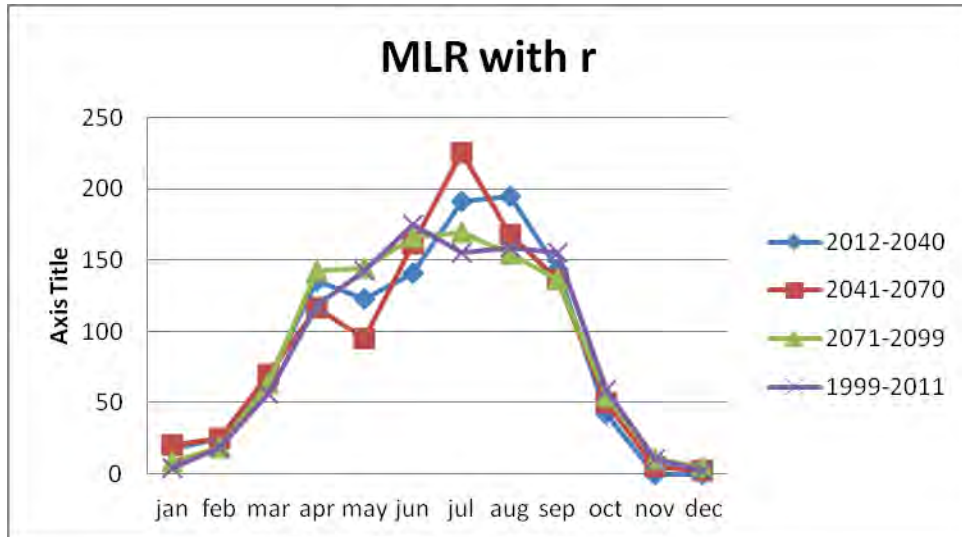

Figure 3.18 *Precipitation for Silchar station*

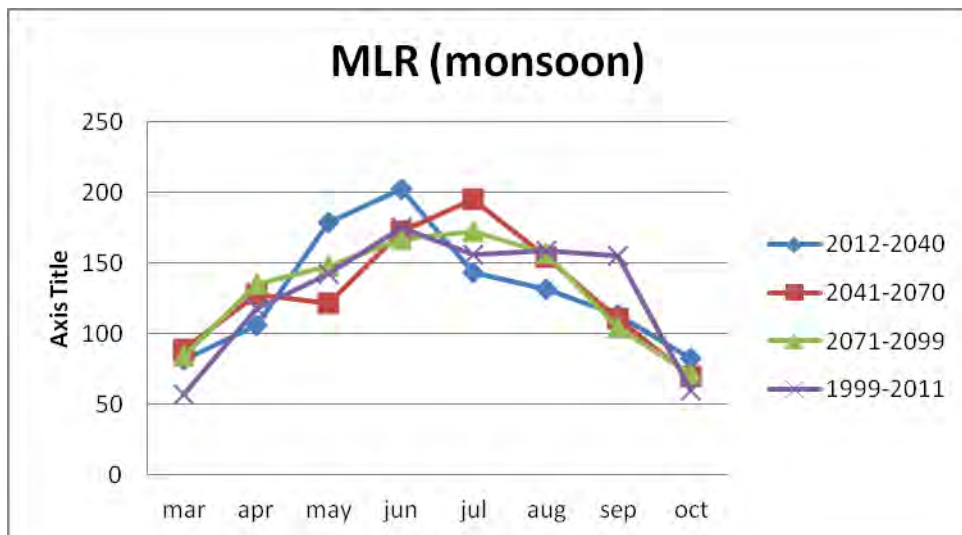

Figure 3.19 *Precipitation for Silchar station in monsoon*

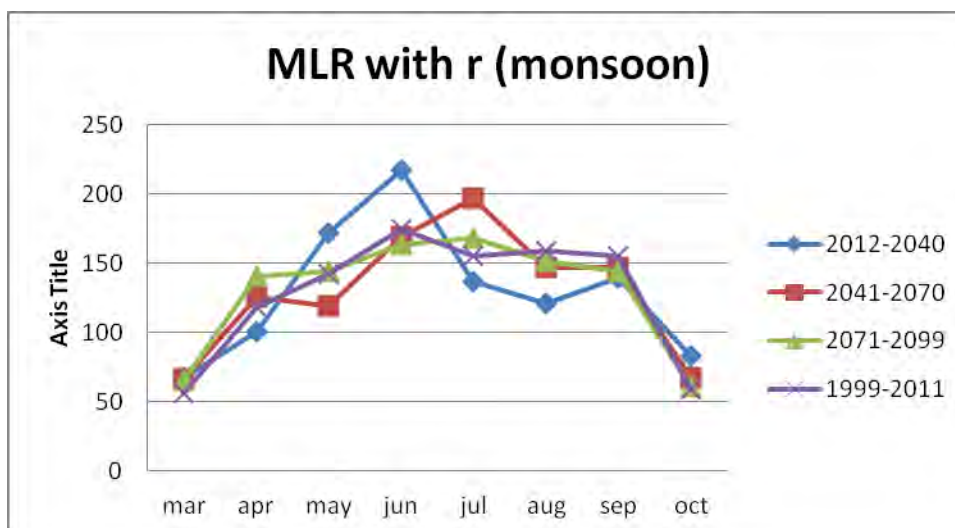

Figure 3. 20 Precipitation for Silchar station in monsoon

The peak value and total annual precipitation (as well as monsoon precipitation where monsoon data are used) for each time series are calculated and tabulated below:

Table 2. 1 Annual peak and total annual precipitation (from MLR)

		MLR			
		1999-2011	2012-2040	2041-2070	2071-2099
maximum value		174.7536938	198.7775606	220.0520334	173.2096936
%age increase			13.74727264	25.92124871	-0.883529355
total ppt		1056.149391	1082.246194	1077.047282	1075.569258
%age increase			2.47093863	1.978687013	1.838742392

Table 2. 2 Annual peak and total annual precipitation (from MLR with r)

		MLR with r			
		1999-2011	2012-2040	2041-2070	2071-2099
maximum value		174.753694	195.159485	225.478676	169.39138
%age increase			11.6768869	29.0265579	-3.06849808
total ppt		1056.14939	1079.86343	1075.45662	1075.45662
%age increase			2.24533005	1.82807743	1.82807743

Table 2. 3 Monsoonal peak and total monsoonal precipitation (from MLR)

		MLR (monsoon)			
		1999-2011	2012-2040	2041-2070	2071-2099
maximum value		174.7536938	202.1613652	194.9772947	172.5367131
%age increase			15.68360063	11.57263139	-1.268631685
total ppt		1020.534337	1038.674952	1038.674952	1038.674952
%age increase			1.777560493	1.777560493	1.777560493

Table 2. 4 Monsoonal peak and total monsoonal precipitation (from MLR with r)

		MLR with r (monsoon)			
		1999-2011	2012-2040	2041-2070	2071-2099
maximum value		174.753694	217.519013	196.648572	168.506864
%age increase			24.4717684	12.5289933	-3.57464799
total ppt		1020.53434	1038.67495	1038.67495	1038.67495
%age increase			1.77756049	1.77756049	1.77756049

From the above analysis, it is found that, peak value of the precipitation is increasing at the beginning i.e. during 2012-2040 and 2041-2070 and then it is showing more or less similar results to the observed precipitation during 2071-2099. When annual data series was considered, it is found that peak of the time series shifts from June to August during the time series 2012-2040 and then it shifts back to July during the time series 2041-2070 and 2071-2099. When monsoon data series was considered, peak remains in June during 2012-2040 and then it shifts to July during 2041-2070 and 2071-2099.

The average increase in total precipitation is found to be 2.1% from MLR analysis whereas from MLR analysis with residual r, it is found to be 1.97%. Average increase in monsoonal precipitation is found to be 1.78% from both the analyses.

Similarly, average value obtained from all the models for each of the time series are shown in the table below:

Table 2.5 Average value obtained from all the models

			2012-2040	2041-2070	2071-2099
avg peak ppt increase (in %)			16.39488216	19.76235784	-2.198826777
avg total ppt increase (in %)			2.067847417	1.840471358	1.805485203

Computed results, based on the average value of all the model outputs, revealed that increase in monthly precipitation during monsoon period is in the order of 20%. However, maximum increase in the value of total yearly precipitation is in the order of 2%, which is not that much significant.

4. CONCLUSION

In the present study, an attempt is made to delineate the North-eastern region of India into some homogeneous clusters based on the Fuzzy Clustering concept and to compare the resulting clusters obtained by using conventional methods and non-conventional methods. For making the clusters, 10 IMD (Indian Meteorological Department) stations, situated in various regions of the North-east, have been selected. On the Basis of IMD data available for those stations, homogeneous clustering has been done. Since the GCM data are available only at the grid points, hence for a particular IMD station, firstly, data of the nearest grid point was taken for the analysis and thereafter interpolated GCM data were calculated for those stations and analyses were done. Clustering has been done considering gridded rainfall data (collected from IMD) also within which all the 10 IMD stations come.

From the results of the FCM it was being noticed that Passighat, North-Lakhimpur, Mohanbari and Tezpur are always coming under the same cluster. Hence it can be concluded that these four stations will always come under the same cluster. Similarly, Shillong, Silchar, Imphal and Cherrapunjee are also coming under the same cluster for most of the analyses. Guwahati is showing similarity with both the clusters. Dhubri, is showing different results; hence clear statement cannot be given. Therefore two clearly visible clusters can be determined from the study, one in the Brahmaputra valley region and the other in Barak valley region.

Presently studies are ongoing on prediction of future rainfall pattern of the Barak Valley region. Four stations have been selected viz. Shillong, Silchar, Imphal and Cherrapunjee for the analysis, which are found to be situated in or near the Barak Valley region and are coming under the same cluster from the FCM analyses. Calibration and validation of the GCM data (HadCM3 with A2 scenario) with relation to precipitation data is over. The future prediction part is ongoing for the stations. Calibration and validation as well as future prediction of rainfall pattern have been done for Silchar. Calibration and validation have been done for different combination of GCM parameters (LSAV data) to find out the best combination of parameters. Based on the calibration-validation results future forecasting has been done for Silchar station. Depending upon availability of LSAV data, suitable models, developed from calibration-validation, have been used for future forecasting.

From the above analysis, it is found that, peak value of the precipitation is increasing at the beginning i.e. during 2012-2040 and 2041-2070 and then it is showing more or less similar results to the observed precipitation during 2071-2099. When annual data series was considered, it is found that peak of the time series shifts from June to August during the time series 2012-2040 and then it shifts back to July during the time series 2041-2070 and 2071-2099. When monsoon data series was considered, peak remains in June during 2012-2040 and then it shifts to July during 2041-2070 and 2071-2099.

The average increase in total precipitation is found to be 2.1% from MLR analysis whereas from MLR analysis with residual r , it is found to be 1.97%. Average increase in monsoonal precipitation is found to be 1.78% from both the analyses.

Computed results, based on the average value of all the model outputs, revealed that increase in monthly precipitation during monsoon period is in the order of 20%. However, maximum increase in the value of total yearly precipitation is in the order of 2%, which is not that much significant.

REFERENCES

Abida H., and Ellouze M. (2006), "Hydrological Delineation of Homogeneous Regions in Tunisia," *Water Resources Management*, vol. 20, pp. 961–977.

Babuska lecture notes.

Barrie Pittock A. (2009), "Climate Change-The science, impacts and solutions," CSIRO publishing, Australia, 2nd edition.

Bezdek J. C. and Pal S. K. (1992), "Fuzzy Models for Pattern Recognition - Methods That Search for Structures in Data," IEEE Press.

Bezdek J. C., Ehrlich R. and Full W. (1984), "FCM: the fuzzy c-means clustering algorithm," *Computers & Geosciences* Vol. 10, No. 2-3, pp. 191-203.

Bezdek J. C., Keller J., Krisnapuram R., Pal N. (1998), "Fuzzy Models and Algorithms for Pattern Recognition and Image Processing," Kluwer Academic Publishers, USA.

"Climate Change 2007: Synthesis Report," IPCC

.Dibike Y. B. and Coulibaly P. (2005), "Hydrologic impact of climate change in the Saguenay watershed: comparison of downscaling methods and hydrologic models," *Journal of Hydrology*, vol. 307, no. 1–4, pp. 145-163.

Divya and Mehrotra R. (1995), "Climate change and hydrology with emphasis on the Indian subcontinent," *Hydrological Sciences Journal*, no. April, pp. 231-242.

"Emissions Scenarios," (2000) IPCC, Cambridge University Press, UK. pp. 570.

Fill H. D., and Stedinger J. R. (1995), "Homogeneity tests based upon Gumbel distribution and a critical appraisal of Dalrymple's test," *Journal of Hydrology*, vol. 166, pp. 81-105.

Gilat Amos (2010), "MATLAB-An introduction with application," WILEY-India Pvt. Ltd, New Delhi.

Gosain A. K., Rao S., and Basuray D. (2006), "Climate change impact assessment on hydrology of Indian river basins," *Current Science*, vol. 90, no. 3, pp. 346-353.

Heyen, H., Zorita E., H. von Storch (1996), "Statistical downscaling of monthly mean North Atlantic air-pressure to sea level anomalies in the Baltic Sea," *Tellus*, vol. 48A, pp. 312-323.

Kalita B. (2012), "Impact of climate change on Stream flow of River Brahmaputra at Pandughat station".

Kang H., An K.-H., Park C.-K., Solis A. L. S., and Stitthichivapak K. (2007), "Multimodel output statistical downscaling prediction of precipitation in the Philippines and Thailand," *Geophysical Research Letters*, vol. 34, no. 15, pp. 1-5.

Kumar R. R. and Sarma A.K. (2010), "Rain Water Harvesting for Negotiating Impact of Variation in Climatic Parameter on Agriculture," Pre Conf. Proc. of Indo-Italian Workshop on Impact of Climate Change and Anthropogenic Activities on Soil and Water Resources, IIT Roorkee, October 22-24.

Mujumdar P. P. (2008), "Implications of climate change for sustainable water resources management in India," *Physics and Chemistry of the Earth, Parts A/B/C*, vol. 33, no. 5, pp. 354-358.

Pelczer I., Ramos J., Dominguez J. I., Gonzalez R. (2007), "Establishment of regional homogeneous zones in a watershed using clustering algorithms", VOL 2, pages 502.

Rahman M. U., Jahan S., and Kamal M. M. (2010), "Response of climate change on the morphological behavior of the major river system of Bangladesh," in *International MIKE by DHI Conference*, p. 41.

Sarma A. K. and Deka S. K. (2011), "Impact of climate change on Precipitation characteristics of Brahmaputra basin".

Sarma A.K. and Sarma B (2012). "Optimal Ecological Management Practices for Minimizing Impact of Climate Change and Watershed Degradation Due to Urbanization," Seventh International Conference on Interdisciplinary Social Science, Barcelona, Spain, 25th to 28th June.

Sarma A.K., Sarma P.K. and Vinnarasi R. (2012), "Climatic Data Collection from Tea Garden and other Sources of Northeast India for Climate Change Study," Report submitted to Climate Change Directorate of MoWR, Govt. of India.

Satyanarayana P., and Srinivas V.V. (2011), "Regionalization of precipitation in data sparse areas using large scale atmospheric variables – A fuzzy clustering approach," *Journal of Hydrology*, vol. 405, pp. 462–473.

Serrat-Capdevila A., Valdés J. B., Pérez J. G., Baird K., Mata L. J., and Maddock T. (2007), "Modeling climate change impacts – and uncertainty – on the hydrology of a riparian system: The San Pedro Basin (Arizona/Sonora)," *Journal of Hydrology*, vol. 347, no. 1–2, pp. 48-66.

Sharma R. H. and Shakya N. M. (2006), "Hydrological changes and its impact on water resources of Bagmati watershed, Nepal," *Journal of Hydrology*, vol. 327, no. 3–4, pp. 315-322.

Thappeta S. K. (2012), "Flow simulation in generalized compound channel considering momentum transfer mechanism".

Tisseuil, C., Vrac, M., Lek, S. and Wade, A. J. (2010), "Statistical downscaling of river flows," *Journal of Hydrology*, vol. 385, no. 1–4, pp. 279-291.

Vinnarasi R. (2012), "Impact of climate change on rainfall and stream flow of dhansiri basin".

Wilby R. L., Hassan H., and Hanaki K. (1997), "Statistical downscaling of hydrometeorological variables using general circulation model output," *Journal of Hydrology*, vol. 205, pp. 1-19.

Wilby R. L., Wigley T. M. L., Conway D., Jones P. D., Hewitson B.C., Main J., and Wilks D. S. (1998), "Statistical downscaling of general circulation model output: A comparison of methods" *Water Resources Research*, vol. 34, no. 11, pp. 2995-3008.

Yount William R. (1988), "Research Design and Statistical Analysis for Christian Ministry," W. R. Yount Publication.

Zhang X. C. (2005), "Spatial downscaling of global climate model output for site-specific assessment of crop production and soil erosion," *Agricultural and Forest Meteorology*, vol. 135, pp. 215-229.